

20/
17

CATALOGO GENERALE
GENERAL CATALOGUE

LEA
CERAMICHE

INDEX / ABC

A/ ABSOLUTE
SLIMTECH
30

B/ BASALTINA STONE PROJECT
244

BASALTINA STONE PROJECT
SLIMTECH
86

BIO LUMBER
294

BIO PLANK
314

BIO RECOVER
284

BIO TIMBER
304

BLOCK
200

C/ CITY
328

CLIFFSTONE
220

D/ DISTRICT
154

DREAMING
270

G/ GOCCIA
332

GOUACHE.10
SLIMTECH
44

L/ LINES
SLIMTECH
104

LINK
354

M/ MAKÒ
182

MAUK
SLIMTECH
128

METROPOLIS
170

N/ NAIVE
SLIMTECH
96

NEST
SLIMTECH
124

NOVA
234

O/ OUTDOOR
264

P/ PIXEL
SLIMTECH
120

PROGETTO L14
346

R/ RE-EVOLUTION
SLIMTECH
36

S/ SHADE
SLIMTECH
52

STONECLAY
192

STREETS IN SHADE
SLIMTECH
58

SUNRISE
320

SYSTEM L2
360

T/ TECNOQUARTZ
254

TIMELESS MARBLE
SLIMTECH
22

TRAME
142

TYPE 32
SLIMTECH
70

W/ WATERFALL
208

WAVES
SLIMTECH
112

WOOD-STOCK
SLIMTECH
60

INDICE

index / index / Inhalt

AZIENDA
4

SLIMTECH
18

GRES AND MORE
138

TECHNICAL INFO
366

IMBALLI
425

PROTECT
444

indice analitico /

	COLLEZIONE PRODUCT	PAGINA PAGE	PROTECT	DESIGN BY	
SLIMTECH	absolute	30			
	basaltina stone project	86			
	gouache.10	44		Diego Grandi	
	lines	104		Patrick Norguet	
	mauk	128		Diego Grandi	
	naïve	96		Patrick Norguet	
	nest	124		HOK Product Design	
	pixel	120		HOK Product Design	
	re-evolution	36			
	shade	52			
	streets in shade	58		Diego Grandi	
	timeless marble	22			
	type 32	70		Diego Grandi	
	waves	112		Patrick Norguet	
	wood-stock	60			
GRES AND MORE	basaltina stone project	244			
	bio lumber	294			
	bio plank	314			
	bio recover	284			
	bio timber	304			
	block / home	200			
	city	328		Diego Grandi	
	cliffstone	220			
	district	154			
	dreaming	270			
	goccia / monoporosa	332		Kravitz Design Inc.	
	makò	182			
	metropolis	170			
	nova	234			
	outdoor	264			
	progetto L14 / monoporosa	346		Gianluca Soddu	
	stoneclay / home	192			
	sunrise / home	320			
	tecnoquartz	254			
	trame	142			
	waterfall	208			
	link / percorsi tattili	354			
system L2 / 20 mm	360				



/ WHEN CREATIVITY MEETS PERFORMANCE





/ VISIONARY DESIGN

Lea Ceramiche è la perfetta sintesi di design visionario e performance tecnologica, partner della creatività ovunque nel mondo per ogni tipo di progetto architettonico che ricerchi distinzione attraverso uno stile unico e riconoscibile.

Lea Ceramiche is the perfect combination of visionary design and technological performance, a creative partner anywhere in the world for any type of architectural project requiring distinction through unique, recognizable style.

Lea Ceramiche est la synthèse parfaite du design visionnaire et de la performance technologique, le partenaire de la créativité partout dans le monde pour les projets architecturaux qui cherchent à se distinguer à travers un style unique et reconnaissable.

Lea Ceramiche ist die perfekte Synthese aus visionärem Design und technologischer Leistung; weltweiter Partner der Kreativität für jede Art von Architektur-Projekt, das auf der Suche nach einem einzigartigen und unverwechselbaren Stil ist.



DIEGO GRANDI



GIANLUCA SODDU



ZAHA HADID ARCHITECTS



PATRICK NORGUET



KRAVITZ DESIGN



/ INSPIRING DESIGNERS

Essere visionari significa collaborare con i protagonisti del design internazionale per coglierne le esigenze, interpretarle al meglio e restituire nuova ispirazione.

Being visionary means working with leading figures in international design to understand their needs, interpret them in the best possible manner, and provide them with new inspiration.

Être visionnaires veut dire collaborer avec les grands noms du design international pour intégrer leurs exigences, les interpréter au mieux et apporter une nouvelle inspiration.

Ein Visionär zu sein bedeutet mit den Protagonisten des internationalen Designs zusammenzuarbeiten, um die Bedürfnisse zu erkennen, sie aufs Beste zu interpretieren und neue Inspiration wiederzugeben.





/ INDUSTRIAL EXPERTISE FOR TECHNICAL PERFECTION

Dal concept di design allo sviluppo produttivo delle collezioni, la ricerca della perfezione in Lea Ceramiche si esprime nel segno della massima competenza tecnica.

From design concept to production development, the search for perfection by Lea Ceramiche is reflected in the company's high level of technical competence.

Du concept de design au développement productif des collections, la recherche de la perfection s'exprime chez Lea Ceramiche sous le signe de la plus grande compétence technique.

Vom Design-Konzept bis zur produktiven Entwicklung der Kollektionen, das Streben nach Perfektion wird bei Lea Ceramiche mit der höchsten technischen Kompetenz zum Ausdruck gebracht.



/ INNOVATION FOR TOP ARCHITECTURE

L'innovazione nel design, l'assoluta affidabilità delle prestazioni tecniche e la capacità di osare e guardare sempre avanti hanno reso Lea Ceramiche una protagonista indiscussa dell'architettura internazionale.

Innovative design, absolute reliability of technical performance, and the capacity to dare and focus on the future have made Lea Ceramiche an undisputed key player in international architecture.

L'innovation dans le design, la fiabilité absolue des performances techniques et la capacité à oser et à toujours aller de l'avant ont fait de Lea Ceramiche un protagoniste incontestable de l'architecture internationale.

Die Innovation im Design, die absolute Zuverlässigkeit der technischen Leistung und die Fähigkeit zu wagen und immer nach vorne zu schauen hat Lea Ceramiche zu einem unangefochtenen Protagonisten der internationalen Architektur gemacht.



CASA MILAN
Milano
Project Studio Fabio Novembre



LAMBORGHINI LOGISTIC CENTER
S. Agata Bolognese (BO)
Project Archilinea / Prospazio



BOSCO VERTICALE
Milano
Project Stefano Boeri Gianandrea Barreca
e Giovanni la Varra



/ REFERENCES

Le collezioni Lea Ceramiche sono versatili e permettono di creare ambientazioni suggestive in linea con le tendenze più contemporanee. Ideali per ambienti domestici o per realizzazioni di alta gamma, trovano impiego ad esempio nel settore alberghiero e nelle zone ad alto traffico come stazioni, aeroporti e centri commerciali. Il forte contenuto di design che caratterizza i prodotti Lea Ceramiche è il filo conduttore di ogni nuovo progetto.

Lea Ceramiche's collections are versatile and allow for the creation of evocative spaces in line with contemporary trends. Perfect for domestic spaces or for high end projects, they are often used, for example, in the hotel industry and in high traffic areas like train stations, airports, and shopping centres. The high level of design which characterizes Lea Ceramiche's products is the backbone of every new project.

Les collections Lea Ceramiche sont universelles et permettent de créer des environnements attractifs, en accord avec les tendances les plus contemporaines. Leur universalité leur confère le pouvoir de s'adapter à tout type d'environnement, allant de l'utilisation domestique à la conception de projets haut de gamme, comme dans les hôtels et dans les zones hautement fréquentées telles que gares, aéroports et centres commerciaux. Le design exceptionnel, caractéristique des produits Lea Ceramiche, devient ainsi le fil conducteur de chaque nouveau projet.

Die Mit LeaLab wird das laminierte Feinsteinzeug Slimtech zu einem mutierenden Material, in der Lage den unerwarteten und überraschenden Designanforderungen entgegen zu kommen. Die technische Kompetenz von Lea Ceramiche und ihre natürliche Fähigkeit, qualitativ hochwertige Produkte herzustellen, bilden eine absolute Garantie, um jedes architektonische Projekt in jeder Phase, wie im Wohnbereich, zu unterstützen. LeaLab steht für den Fortschritt bei der Personalisierung von keramischen Produkten.
Für weitere Informationen: www.leaceramiche.com.



/ SHOWROOM

Lea Ceramiche Showroom, in Via Durini 3 a Milano è un luogo di relazione: progettato per mostrare le superfici ceramiche nelle declinazioni dell'abitare e per offrire la possibilità di ospitare eventi, installazioni, allestimenti.

Lea Ceramiche Showroom, Via Durini 3 in Milan, is a place to relate: designed to show tile surfaces, interior decoration ideas and offer the opportunity to host events, shows and exhibitions.

Lea Ceramiche Showroom, Via Durini 3, à Milan, est un lieu de relation: pensé pour montrer les superficies céramique dans les nouvelles déclinaisons des scénarios habitatifs et pour offrir la possibilité d'accueillir événements, installations et expositions.

Lea Ceramiche Showroom in Mailand in Via Durini 3 ist ein Ort der Begegnung: er wurde eingerichtet um Veranstaltungen, Installationen und Ausstellungen zu organisieren und um die keramischen Oberflächen für die Inneneinrichtung live auszustellen.

Slimtech è la soluzione che completa il progetto di superfici di Lea Ceramiche offrendo lastre di dimensioni oversize abbinate ad una straordinaria leggerezza. È il frutto di una tecnologia di laminazione e compattazione del gres porcellanato che rivoluziona il processo produttivo tradizionale ed ottiene così un prodotto completamente nuovo, resistente, leggero, flessibile, duttile e versatile. Slimtech soddisfa pienamente le esigenze più attuali della moderna progettazione sia per interni che per le ampie superfici esterne degli edifici contemporanei. È facile da installare e risolve, meglio di qualunque altro materiale, le problematiche del rinnovo offrendo risultati estetici eccellenti.

Slimtech is the solution that completes Lea Ceramiche's collection of products for surfaces, offering oversized slabs that are extraordinarily lightweight. It is the fruit of a lamination and compaction technology for porcelain stoneware that revolutionizes the traditional manufacturing process, thus creating a completely new, resistant, lightweight, flexible, ductile and versatile product. Slimtech fully satisfies the today's demands of modern design, both for interiors and for large exterior surfaces of contemporary buildings. It's easy to install and solves, better than any other material, renovation issues, providing excellent aesthetic results.

Slimtech est la solution innovante en matière de surfaces qui complète le projet de Lea Ceramiche en proposant des dalles XXL dotées d'une extrême légèreté. Grâce à une technologie innovante de laminage et de compactage du grès cérame, qui révolutionne ainsi le processus traditionnel de production, nous avons donné naissance à un produit entièrement innovant, résistant, léger, flexible, souple et universel. Slimtech satisfait pleinement aux exigences les plus actuelles de conception moderne d'intérieurs et de grandes surfaces d'extérieur des bâtiments contemporains. Son installation est simple et résout, mieux que tout autre matériau, les problèmes liés à la rénovation, offrant des résultats d'une excellence esthétique.

Slimtech mit ihren überdimensional großen und außergewöhnlich leichten Platten ist die Lösung, die das Projekt der Oberflächen von Lea Ceramiche ergänzt. Slimtech ist das Ergebnis einer Laminierungs- und Verdichtungstechnologie für Feinsteinzeug, die das traditionelle Herstellungsverfahren revolutioniert, mit dem Erhalt eines völlig neuen, langlebigen, leichten, biegsamen und vielseitigen Produkts. Slimtech erfüllt in vollem Umfang die Anforderungen des heutigen modernen Design für die weitreichenden Innen- und Außenflächen der zeitgenössischen Gebäude. Es ist leicht zu verlegen und löst dank des Erhalts hervorragender ästhetischer Ergebnisse besser als jedes andere Material die bei der Renovierung auftretenden Problematiken.

22

30

36

44

52

58

60

70

86

96

104

112

120

124

128

134

136

timeless marble

marble

absolute

re-evolution

gouache.10

contemporary

shade

streets in shade

wood-stock

wood

type 32

basaltina stone project

stone

naive

lines

waves

shapes & colors

pixel

nest

mauk

lealab

destinazioni d'uso

SLIMTECH

SPESSORE

Thickness / Epaisseur / Stärke



3 mm

solo per rivestimenti
wall applications only /
pour revêtements de murs seulement /
nur für Verkleidungen /

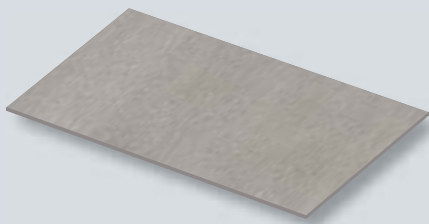

3,5 mm

SLIMTECH 3PLUS

rinforzata con stuoia in fibra di vetro, per
rivestimenti e pavimenti / reinforced with a sheet
of fiberglass, for wall and floor applications /
renforcé au dos par une natte en fibre de verre,
pour revêtements sols et murs / mit Glasfasermatte
verstärkt, Für Wand und Boden geeignet /

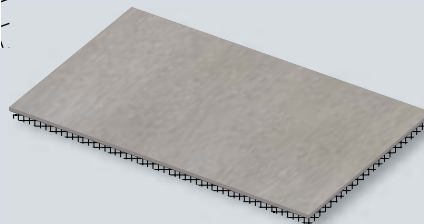

FORMATI (CM)

Sizes - Formats - Formate

	100x300	33x300	20x200	50x150	20x150	100x100	50x100	33x100	20x100	4,9x100
Absolute	•					•		•		
Basaltina Stone P.	•					•	•			•
Gouache.10	•					•	•			•
Lines	•									
Mauk										
Naive	•					•				
Nest										
Pixel	•						•			
Re-evolution	•					•	•			•
Shade	•					•	•			•
Timeless Marble	•			•		•		•		
Type 32			•							
Waves	•									
Wood-stock		•	•		•				•	



5,5 mm

SLIMTECH 5PLUS

rinforzata con stuoia in fibra di vetro, per rivestimenti e pavimenti ad alto traffico / reinforced with a sheet of fiberglass, for wall cladding and high traffic floor applications / renforcé au dos par une natte en fibre de verre, pour revêtements de sols au passage intensif et de murs / mit Glasfasermatte verstärkt, für Wand stark frequentierte Böden geeignet /

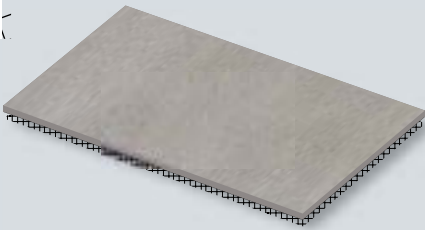

GRES LAMINATO RINFORZATO CON FIBRA DI VETRO

UN PRODOTTO SUPERIORE

- Più resistente
- Più affidabile
- Più leggero e adatto alle ristrutturazioni
- Più facile da lavorare e movimentare
- Più sicuro
- Più flessibile

LAMINATED PORCELAIN STONWARE REINFORCED WITH FIBREGLASS

A SUPERIOR PRODUCT

- More resistant
- More reliable
- Lighter and suitable for renovations
- Easier to work with and handle
- Safer
- More flexible

GRÈS CÉRAME LAMINÉ, RENFORCÉ AVEC DE LA FIBRE DE VERRE

UN PRODUIT SUPÉRIEUR

- Plus résistant
- Plus fiable
- Plus léger et adapté aux projets de restructurations
- Plus facile à travailler et à déplacer
- Plus sûr

MIT GLASFASERN VERSTÄRKTES FEINSTEINZEUG

EIN QUALITÄTSPRODUKT

- Widerstandsfähiger
- Zuverlässiger
- Leichter und für Renovierungen geeignet
- Leichter zu bearbeiten und zu handhaben
- Sicherer
- Biegsamer



	50x50	12,5x50	8,7x13,5x25,8	38,3	57,6	100x86,6	50x43,2	12,5x10,8	100x86,6	50x43,2	12,5x10,8
	•										
	•										
			•	•	•						
						•	•	•	•	•	•
		•									
	•										
	•										

marble



CALACATTA GOLD EXTRA

100x300cm / 39"x118"
lev

100x100cm / 39"x39"
lev



TIMELESS MARBLE

PROTECT
ANTIBATTERICO - ANTIMICROBIAL

SLIMTECH

4

FORMATI

sizes / formats / Formate



33x100 cm / 13"x39"
slimtech 5plus

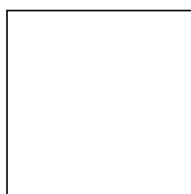

100x100cm / 39"x39"
slimtech 5plus

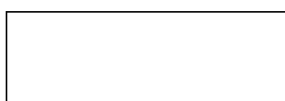

50x150cm / 19^{1/2}"x59"
slimtech 5plus

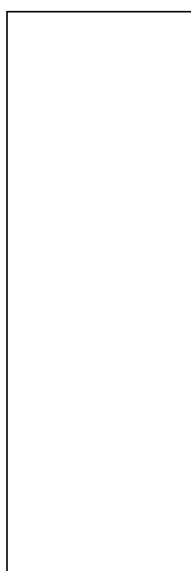

100x300cm / 39"x118"
slimtech 5plus

2

FINITURE

finishes / surfaces / Oberfläche

LEV

SAT

5

COLORI

colors / couleurs / Farben



Calacatta Gold Extra



Pietra Gray



Safari Amande



Statuario White

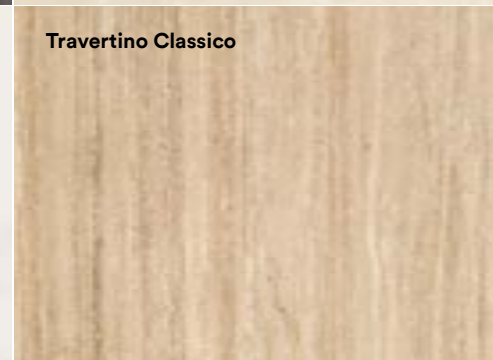

Travertino Classico

marble



TIMELESS MARBLE

STATUARIO WHITE
100x300cm / 39"x118"
lev

50x150cm / 19 1/2"x59"
lev





TRAVERTINO CLASSICO
50x150cm / 19¹/₂"x59"
lev



marble



TIMELESS MARBLE

PIETRA GRAY

100x100 cm / 39"x39"
lev

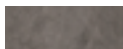

SAFARI AMANDE

33x100cm / 13"x39"
lev



TIMELESS MARBLE

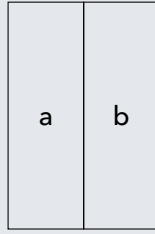

CALACATTA BUTTERFLY A
100x300cm / 39"x118"



LEV LSATMYA
SAT LSATMSA

CALACATTA BUTTERFLY B
100x300cm / 39"x118"



LEV LSATMYB
SAT LSATMSB

TIMELESS MARBLE

GRES LAMINATO UGL

Laminated porcelain UGL / Grès laminé UGL
Laminiertes Feinsteinzeug UGL

SPESSORE

Thickness / Epaisseur / Stärke
5,5 mm → slimtech 5plus



STONALIZZAZIONE

Shading / Denuançage / Spielfarbig

DYNAMIC COEFFICIENT OF FRICTION ANSI A 137.1:2012

DCOF ≥ 0.42 (sat)

FINITURA LEV

Lev surface finish / Finition LEV
LEV Oberfläche

Ideale per rivestimenti e per pavimenti in ambienti residenziali.

Suitable for wall coverings and floors in residential applications.

Idéal pour revêtements et sols pour locaux résidentiels privés.

Für Wand und Boden im Wohnbereich geeignet.

FINITURA SAT

Sat surface finish / Finition SAT
SAT Oberfläche

Ideale per rivestimenti e per pavimenti in ambienti residenziali e commerciale leggero.

Suitable for wall coverings and floors in both residential and light-commercial applications.

Idéal pour revêtements et sols pour locaux résidentiels privés et commercial léger.

Für Wand und Boden im Wohn- und leichte kommerzielle Bereiche geeignet / Ideal para.

FUGA MINIMA CONSIGLIATA PER POSA IN INTERNO

Minimum suggested joint for indoor fixing
Joint minimum conseillé pour pose en intérieure
Empfohlene Fugenbreite fuer Innenbereich

PARETE / Wall / Mur / Wand

1 mm → slimtech 5plus

PAVIMENTO / Floor / Sol / Boden

2 mm → slimtech 5plus

IMBALLI

Packing / Emballage / Verpackung
pag. 433

P R () T E C T

ANTIBATTERICO - ANTIMICROBIAL

FONDI

plain tiles / fonds / Unifliesen

		33x100cm 13"x39"		100x100cm 39"x39"		50x150cm 19 1/2"x59"		100x300cm* 39"x118"	
		Slimtech 5plus		Slimtech 5plus		Slimtech 5plus		Slimtech 5plus Slimtech 5mm**	
Calacatta Gold Extra		LEV	LS5TMX4	LSCTMX4	LS0TMX4	LS0TMX4	LSATMX9		
		SAT	LS5TM40	LSCTM40	LS0TM40	LS0TM40	LSATM40		
Safari Amande		LEV	LS5TMX1	LSCTMX1	LS0TMX1	LS0TMX1	LSATMX1		
		SAT	LS5TM10	LSCTM10	LS0TM10	LS0TM10	LSATM10		
Travertino Classico		LEV	LS5TMX3	LSCTMX3	LS0TMX3	LS0TMX3	LSATMX3		
		SAT	LS5TM30	LSCTM30	LS0TM30	LS0TM30	LSATM30		
Pietra Gray		LEV	LS5TMX2	LSCTMX2	LS0TMX2	LS0TMX2	LSATMX2		
		SAT	LS5TM20	LSCTM20	LS0TM20	LS0TM20	LSATM20		
Statuario White		LEV	LS5TMX0	LSCTMX0	LS0TMX0	LS0TMX0	LSATMX0		
		SAT	LS5TM00	LSCTM00	LS0TM00	LS0TM00	LSATM00		

* Per ordini inferiori alle 5 lastre sarà addebitato il costo del pallet a Euro 80,00 netto. / The cost of the pallet, Euro 80,00 net, will be charged for orders less than 5 slabs. / Pour toutes commandes inférieures à 5 dalles, un cout de 80 Euro correspondant au cout de la palette sera ajouté. / Bei Abnahme einer Menge unter 5 Platten werden Euro 80,00 Netto für Verpackung/palette belastet.

** Su richiesta. Per maggiori informazioni circa quantità minime e tempi di consegna rivolgersi all'ufficio commerciale. / Upon request. For more information about minimum quantities and delivery times please contact the sales department. / Sur demande. Pour plus d'informations sur les quantités minimales et délais de livraison s'il vous plaît contacter le département des ventes. / auf Anfrage. Für weitere Infos über die Mindestmengen und Lieferzeiten wenden Sie sich bitte an unserer Verkaufsabteilung.

contemporary



TOTAL BLACK

100x300cm / 39"x118"
lev

33x100cm / 13"x39"
sat (volume)



TOTAL WHITE

100x100cm / 39"x39"
sat

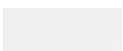

ABSOLUTE

PROTECT
ANTIBATTERICO - ANTIMICROBIAL

SLIMTECH

3
FORMATI
sizes / formats / Formate

2
FINITURE
finishes / surfaces / Oberfläche

2
COLORI
colors / couleurs / Farben



33x100 cm / 13"x39"
slimtech 5plus

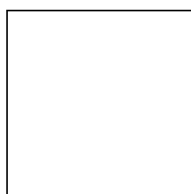

100x100cm / 39"x39"
slimtech 5plus

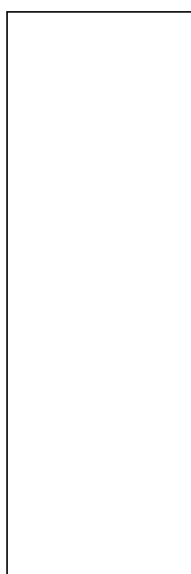

100x300cm / 39"x118"
slimtech 5plus

LEV

SAT

Total White

Total Black



AD EFGH
J LMNOPO
ST VWXY
Zabcde fghijk
l mnpq r s t
vwx yz 123456
7890&@#%*

ABSOLUTE

TOTAL WHITE

100x300cm / 39"x118"

sat

100x100cm / 39"x39"

sat

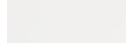

32/
33



TOTAL BLACK

33x100cm / 13"x39"

lev





ABSOLUTE

TOTAL BLACK

33x100cm / 13"x39"
sat



TOTAL WHITE

100x300cm / 39"x118"
lev

33x100cm / 13"x39"
sat



ABSOLUTE

GRES LAMINATO UGL

Laminated porcelain UGL / Grès laminé UGL
Laminiertes Feinsteinzeug UGL

SPESORE

Thickness / Epaisseur / Stärke
5,5 mm → slimtech 5plus



STONALIZZAZIONE

Shading / Denuançage / Spielfarbig

IMBALLI

Packing / Emballage / Verpackung
pag. 425

FINITURA LEV

Lev surface finish / Finition LEV
LEV Oberfläche

Ideale per rivestimenti e per pavimenti in ambienti residenziali.

Suitable for wall coverings and floors in residential applications.

Idéal pour revêtements et sols pour locaux résidentiels privés.

Für Wand und Boden im Wohnbereich geeignet.

FINITURA SAT

Sat surface finish / Finition SAT
SAT Oberfläche

Ideale per rivestimenti e per pavimenti in ambienti residenziali e commerciale leggero.

Suitable for wall coverings and floors in both residential and light-commercial applications.

Idéal pour revêtements et sols pour locaux résidentiels privés et commercial léger.

Für Wand und Boden im Wohn- und leichte kommerzielle Bereiche geeignet / Ideal para.

FUGA MINIMA CONSIGLIATA PER POSA IN INTERNO

Minimum suggested joint for indoor fixing
Joint minimum conseillé pour pose en intérieure
Empfohlene Fugenbreite fuer Innenbereich

PARETE / Wall / Mur / Wand

1 mm → slimtech 5plus

PAVIMENTO / Floor / Sol / Boden

2 mm → slimtech 5plus

DYNAMIC COEFFICIENT OF FRICTION ANSI A 137.1:2012

DCOF ≥ 0.42 (sat)

P R () T E C T

ANTIBATTERICO - ANTIMICROBIAL

FONDI

plain tiles / fonds / Unifliesen

	33x100cm 13"x39"	100x100cm 39"x39"	100x300cm* 39"x118"
	slimtech 5plus	slimtech 5plus	slimtech 5plus slimtech 5mm**
Total white	LEV LS5ABX0	LSCABX0	LSAABX0
	SAT LS5AB00	LSCAB00	LSAAB00
Total black	LEV LS5ABX1	LSCABX1	LSAABX1
	SAT LS5AB10	LSCAB10	LSAAB10

* Per ordini inferiori alle 5 lastre sarà addebitato il costo del pallet a Euro 80,00 netto. / The cost of the pallet, Euro 80,00 net, will be charged for orders less than 5 slabs. / Pour toutes commandes inférieures à 5 dalles, un cout de 80 Euro correspondant au cout de la palette sera ajouté. / Bei Abnahme einer Menge unter 5 Platten werden Euro 80,00 Netto für Verpackung/palette belastet.

** Su richiesta. Per maggiori informazioni circa quantità minime e tempi di consegna rivolgersi all'ufficio commerciale. / Upon request. For more information about minimum quantities and delivery times please contact the sales department. / Sur demande. Pour plus d'informations sur les quantités minimales et délais de livraison s'il vous plaît contacter le département des ventes. / auf Anfrage. Für weitere Infos über die Mindestmengen und Lieferzeiten wenden Sie sich bitte an unserer Verkaufsabteilung.

contemporary



SRC030
100x300cm / 39"x118"

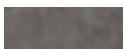

SRC010
100x100cm / 39"x39"



RE-EVOLUTION



5

FORMATI

sizes / formats / Formate



4,9x100cm / 2"x39"
slimtech 3plus

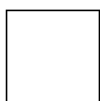

50x50cm / 19¹/₂"x19¹/₂"
slimtech 3plus



50x100cm / 19¹/₂"x39"
slimtech 3mm
slimtech 3plus

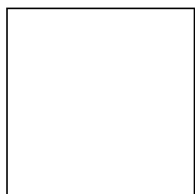

100x100cm / 39"x39"
slimtech 3plus

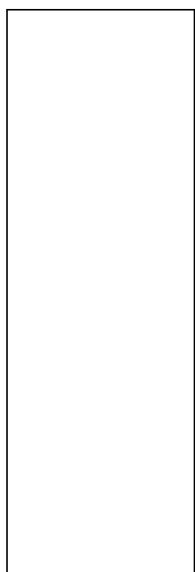

100x300cm / 39"x118"
slimtech 3mm
slimtech 3plus

6

COLORI

colors / couleurs / Farben







SRW020
100x100cm / 39"x39"



contemporary

RE-EVOLUTION



SRC020
100x300cm / 39"x118"





RE-EVOLUTION

SRC020
100x300cm / 39"x118"

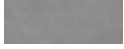

SRW010
100x100cm / 39"x39"

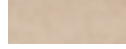

RE-EVOLUTION

GRES LAMINATO UGL

Laminated porcelain UGL / Grès laminé UGL
Laminiertes Feinsteinzeug UGL

SPESSORE

Thickness / Epaisseur / Stärke

3 mm → slimtech 3mm

3,5 mm → slimtech 3plus

 SLIMTECH



STONALIZZAZIONE

Shading / Denuançage / Spielfarbig

FUGA MINIMA CONSIGLIATA PER POSA IN INTERNO

Minimum suggested joint for indoor fixing
Joint minimum conseillé pour pose en interieure
Empfohlene Fugenbreite fuer Innenbereich

PARETE / Wall / Mur / Wand

1 mm → slimtech 3mm - slimtech 3plus

PAVIMENTO / Floor / Sol / Boden

2 mm → slimtech 3plus

IMBALLI

Packing / Emballage / Verpackung

pag. 432

FONDI

plain tiles / fonds / Unifliesen

		4,9x100cm 2"x39"	50x50cm 19 ¹ / ₂ "x19 ¹ / ₂ "	50x100cm 19 ¹ / ₂ "x39"	50x100cm 19 ¹ / ₂ "x39"	100x100cm 39"x39"	100x300cm* 39"x118"	100x300cm* 39"x118"
		slimtech 3plus	slimtech 3plus	slimtech 3mm	slimtech 3plus	slimtech 3plus	slimtech 3mm	slimtech 3plus
SRW010		LSERE65	LSDRE65	LSBRE60	LSBRE65	LSCRE65	LSARE60	LSARE65
SRW020		LSERE75	LSDRE75	LSBRE70	LSBRE75	LSCRE75	LSARE70	LSARE75
SRW030		LSERE85	LSDRE85	LSBRE80	LSBRE85	LSCRE85	LSARE80	LSARE85
SRC010		LSERE15	LSDRE15	LSBRE10	LSBRE15	LSCRE15	LSARE10	LSARE15
SRC020		LSERE25	LSDRE25	LSBRE20	LSBRE25	LSCRE25	LSARE20	LSARE25
SRC030		LSERE35	LSDRE35	LSBRE30	LSBRE35	LSCRE35	LSARE30	LSARE35

* Per ordini inferiori alle 5 lastre sarà addebitato il costo del pallet a Euro 80,00 netto. / The cost of the pallet, Euro 80,00 net, will be charged for orders less than 5 slabs. / Pour toutes commandes inférieures à 5 dalles, un cout de 80 Euro correspondant au cout de la palette sera ajouté. / Bei Abnahme einer Menge unter 5 Platten werden Euro 80,00 Netto für Verpackung/palette belastet.

contemporary



CRYSTAL WATER
100x300cm / 39"x118"

100x100cm / 39"x39"



GOUACHE.10

DESIGN DIEGO GRANDI



5

FORMATI

sizes / formats / Formate



4,9x100cm / 2"x39"
slimtech 3plus



50x50cm / 19¹/₂"x19¹/₂"
slimtech 3plus



50x100cm / 19¹/₂"x39"
slimtech 3mm
slimtech 3plus



100x100cm / 39"x39"
slimtech 3plus

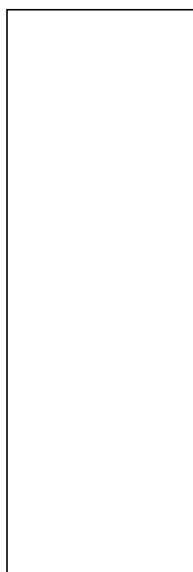

100x300cm / 39"x118"
slimtech 3mm
slimtech 3plus

7

COLORI

colors / couleurs / Farben



contemporary





GOUACHE.10

DEEP SEA
100x100cm / 39"x39"

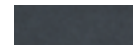

contemporary

GOUACHE.10

LIBECCIO 01 COLD
15,4x22,3cm / 6^{1/8}"x8^{3/4}"



DECORI

decors / decors / dekore

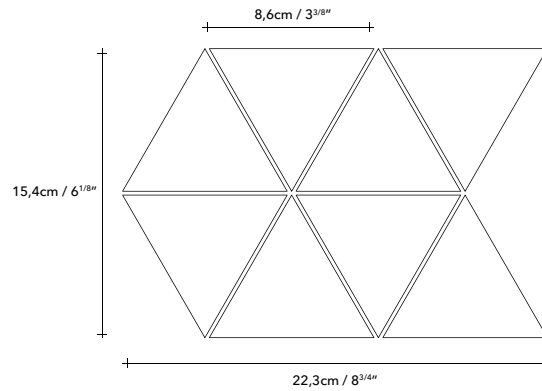

LIBECCIO
white cloud
15,4x22,3cm / 6 1/8"x8 3/4"



LIBECCIO
crystal water
15,4x22,3cm / 6 1/8"x8 3/4"



LIBECCIO 01
warm
15,4x22,3cm / 6 1/8"x8 3/4"



LIBECCIO
soft sand
15,4x22,3cm / 6 1/8"x8 3/4"



LIBECCIO
cool rain
15,4x22,3cm / 6 1/8"x8 3/4"



LIBECCIO 01
cold
15,4x22,3cm / 6 1/8"x8 3/4"



LIBECCIO
light rock
15,4x22,3cm / 6 1/8"x8 3/4"



LIBECCIO
deep sea
15,4x22,3cm / 6 1/8"x8 3/4"



LIBECCIO 02
15,4x22,3cm / 6 1/8"x8 3/4"



LIBECCIO
black stone
15,4x22,3cm / 6 1/8"x8 3/4"



LIBECCIO 03
15,4x22,3cm / 6 1/8"x8 3/4"









GOUACHE.10

CRYSTAL WATER
100x300cm / 39"x118"

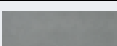

DECORI

decors / decors / Dekore

		LIBECCIO	LIBECCIO 01	LIBECCIO 02	LIBECCIO 03
		15,4x22,3cm 6 1/8" x 8 3/4"	15,4x22,3cm 6 1/8" x 8 3/4"	15,4x22,3cm 6 1/8" x 8 3/4"	15,4x22,3cm 6 1/8" x 8 3/4"
White Cloud		LS9GU03	-	-	-
Soft Sand		LS9GU04	-	-	-
Light Rock		LS9GU01	-	-	-
Black Stone		LS9GU05	-	-	-
Crystal Water		LS9GU02	-	-	-
Cool Rain		LS9GU00	-	-	-
Deep Sea		LS9GU06	-	-	-
Warm		-	LS9GU08	-	-
Cold		-	LS9GU07	-	-
Color mix		-	-	LS9GU09	LS9GU10

GOUACHE.10

GRES LAMINATO UGL

Laminated porcelain UGL / Grès laminé UGL
Laminiertes Feinsteinzeug UGL

SPESSORE

Thickness / Epaisseur / Stärke

3 mm → slimtech 3mm
3,5 mm → slimtech 3plus



STONALIZZAZIONE

Shading / Denuançage / Spielfarbig

DYNAMIC COEFFICIENT OF FRICTION ANSI A 137.1:2012

DCOF \geq 0.42 (3plus)

COEFFICIENTE DI ATTRITO DINAMICO B.C.R. TORTUS

$\mu > 0,40$ (3plus)

RESISTENZA ALLO SCIVOLAMENTO DIN 51130

Slip resistance / Résistance au glissement
Rutschfestigkeit

R9 (3plus)

FUGA MINIMA CONSIGLIATA PER POSA IN INTERNO

Minimum suggested joint for indoor fixing
Joint minimum conseillé pour pose en intérieure
Empfohlene Fugenbreite fuer Innenbereich

PARETE / Wall / Mur / Wand

1 mm → slimtech 3mm - slimtech 3plus

PAVIMENTO / Floor / Sol / Boden

2 mm → slimtech 3plus

IMBALLI

Packing / Emballage / Verpackung

pag. 428

FONDI

plain tiles / fonds / Unifliesen

		4,9x100cm 2"x39"	50x50cm 19 1/2"x19 1/2"	50x100cm 19 1/2"x39"	50x100cm 19 1/2"x39"	100x100cm 39"x39"	100x300cm* 39"x118"	100x300cm* 39"x118"
		Slimtech 3plus	Slimtech 3plus	Slimtech 3mm	Slimtech 3plus	Slimtech 3plus	Slimtech 3mm	Slimtech 3plus
White Cloud		LSEGU35	LSDGU35	LSBGU30	LSBGU35	LSCGU35	LSAGU31	LSAGU36
Soft Sand		LSEGU25	LSDGU25	LSBGU20	LSBGU25	LSCGU25	LSAGU21	LSAGU26
Light Rock		LSEGU15	LSDGU15	LSBGU10	LSBGU15	LSCGU15	LSAGU11	LSAGU16
Black Stone		LSEGU05	LSDGU05	LSBGU00	LSBGU05	LSCGU05	LSAGU01	LSAGU06
Crystal Water		LSEGU45	LSDGU45	LSBGU40	LSBGU45	LSCGU45	LSAGU41	LSAGU46
Cool Rain		LSEGU55	LSDGU55	LSBGU50	LSBGU55	LSCGU55	LSAGU51	LSAGU56
Deep Sea		LSEGU65	LSDGU65	LSBGU60	LSBGU65	LSCGU65	LSAGU61	LSAGU66

* Per ordini inferiori alle 5 lastre sarà addebitato il costo del pallet a Euro 80,00 netto. / The cost of the pallet, Euro 80,00 net, will be charged for orders less than 5 slabs. / Pour toutes commandes inférieures à 5 dalles, un cout de 80 Euro correspondant au cout de la palette sera ajouté. / Bei Abnahme einer Menge unter 5 Platten werden Euro 80,00 Netto für Verpackung/palette belastet.

contemporary



MILK
100x300cm / 39"x118"

100x100cm / 39"x39"



SHADE

52/
53

 SLIMTECH

5

FORMATI

sizes / formats / Formate



4,9x100cm / 2"x39"
slimtech 3plus



50x50cm / 19¹/₂"x19¹/₂"
slimtech 3plus



50x100cm / 19¹/₂"x39"
slimtech 3mm
slimtech 3plus



100x100cm / 39"x39"
slimtech 3plus

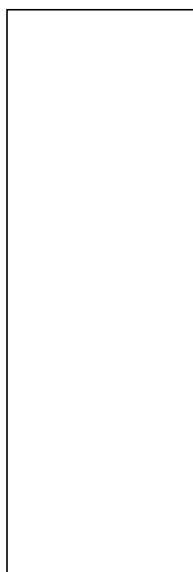

100x300cm / 39"x118"
slimtech 3mm
slimtech 3plus

2

COLORI

colors / couleurs / Farben

Milk

Black Coffee

contemporary

SHADE

MILK

100x300cm / 39"x118"

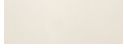

BLACK COFFEE

100x300cm / 39"x118"

100x100cm / 39"x39"





contemporary

SHADE

BLACK COFFEE
100x100cm / 39"x39"



SHADE

GRES LAMINATO UGL

Laminated porcelain UGL / Grès laminé UGL
Laminiertes Feinsteinzeug UGL

SPESSORE

Thickness / Epaisseur / Stärke

3 mm → slimtech 3mm

3,5 mm → slimtech 3plus

 SLIMTECH



STONALIZZAZIONE

Shading / Denuançage / Spielfarbig

DYNAMIC COEFFICIENT OF FRICTION ANSI A 137.1:2012

DCOF \geq 0.42 (3plus)

COEFFICIENTE DI ATTRITO DINAMICO B.C.R. TORTUS

$\mu > 0,40$ (3plus)

RESISTENZA ALLO SCIVOLAMENTO DIN 51130

Slip resistance / Résistance au glissement
Rutschfestigkeit

R9 (3plus)

FUGA MINIMA CONSIGLIATA PER POSA IN INTERNO

Minimum suggested joint for indoor fixing
Joint minimum conseillé pour pose en interieure
Empfohlene Fugenbreite fuer Innenbereich

PARETE / Wall / Mur / Wand

1 mm → slimtech 3mm - slimtech 3plus

PAVIMENTO / Floor / Sol / Boden

2 mm → slimtech 3plus



IMBALLI

Packing / Emballage / Verpackung

pag. 432

FONDI

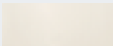
plain tiles / fonds / Unifliesen

	4,9x100cm 2"x39"	50x50cm 19 1/2"x19 1/2"	50x100cm 19 1/2"x39"	50x100cm 19 1/2"x39"	100x100cm 39"x39"	100x300cm* 39"x118"	100x300cm* 39"x118"
	slimtech 3plus	slimtech 3plus	slimtech 3mm	slimtech 3plus	slimtech 3plus	slimtech 3mm	slimtech 3plus
Milk 	LSESD05	LSDSD05	LSBSD00	LSBSD05	LSCSD05	LSASD00	LSASD05
Black Coffee 	LSESD15	LSDSD15	LSBSD10	LSBSD15	LSCSD15	LSASD10	LSASD15

* Per ordini inferiori alle 5 lastre sarà addebitato il costo del pallet a Euro 80,00 netto. / The cost of the pallet, Euro 80,00 net, will be charged for orders less than 5 slabs. / Pour toutes commandes inférieures à 5 dalles, un cout de 80 Euro correspondant au cout de la palette sera ajouté. / Bei Abnahme einer Menge unter 5 Platten werden Euro 80,00 Netto für Verpackung/palette belastet.

contemporary

**STREETS
MELBOURNE**

50x100cm / 19¹/₂"x39"

STREETS IN SHADE

DESIGN DIEGO GRANDI

 SLIMTECH

1

FORMATO

size / format / Format

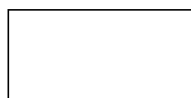

50x100cm / 19¹/₂"x39"
slimtech 3mm

2

COLORI

colors / couleurs / Farben

STREETS KYOTO
50X100cm / 19¹/₂"X39"



LSBSD17

STREETS MELBOURNE
50X100cm / 19¹/₂"X39"



LSBSD18

IMBALLI

Packing / Emballage /
Verpackung

pag. 432

wood



COFFEE WOOD

20x200cm / 8"x79"

Type-32 coffee δ W 25



WOOD-STOCK

PROTECT
ANTIBATTERICO - ANTIMICROBIAL

S LIMTECH

4

FORMATI

sizes / formats / Formate

5

COLORI

colors / couleurs / Farben

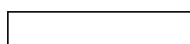

20x100cm / 8"x39"
slimtech 5plus



20x150cm / 8"x59"
slimtech 5plus



20x200cm / 8"x79"
slimtech 5plus

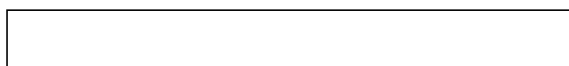

33x300cm / 13"x118"
slimtech 5plus

Snow Wood



Vintage Wood



Cream Wood



Coffee Wood



Honey Wood



wood



WOOD-STOCK

CREAM WOOD
33x300cm / 13" x 118"





wood





WOOD-STOCK

64/
65

SNOW WOOD
20x200cm / 8"x79"

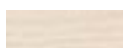

wood



WOOD-STOCK

VINTAGE WOOD
20x150cm / 8"x59"



66/
67



HONEY WOOD
33x300cm / 13"x118"



wood



WOOD-STOCK

COFFEE WOOD

20x200cm / 8"x79"

Type-32 coffee δ W 25



WOOD-STOCK

GRES LAMINATO UGL

Laminated porcelain UGL / Grès laminé UGL
Laminiertes Feinsteinzeug UGL

SPESSORE

Thickness / Epaisseur / Stärke

5,5 mm → slimtech 5plus



STONALIZZAZIONE

Shading / Denuançage / Spielfarbig

DYNAMIC COEFFICIENT OF FRICTION ANSI A 137.1:2012

DCOF \geq 0.42

COEFFICIENTE DI ATTRITO DINAMICO B.C.R. TORTUS

$\mu > 0,40$

RESISTENZA ALLO SCIVOLAMENTO DIN 51130

Slip resistance / Résistance au glissement
Rutschfestigkeit

R10

FUGA MINIMA CONSIGLIATA PER POSA IN INTERNO

Minimum suggested joint for indoor fixing
Joint minimum conseillé pour pose en interieure
Empfohlene Fugenbreite fuer Innenbereich

PARETE / Wall / Mur / Wand

1 mm → slimtech 5plus

PAVIMENTO / Floor / Sol / Boden

2 mm → slimtech 5plus

IMBALLI

Packing / Emballage / Verpackung

pag. 435

P R () T E C T

ANTIBATTERICO - ANTIMICROBIAL

FONDI

plain tiles / fonds / Unifliesen

		20x100cm 8"x39"	20x150cm 8"x59"	20x200cm 8"x79"	33x300cm* 13"x118"
		slimtech 5plus	slimtech 5plus	slimtech 5plus	slimtech 5plus
Snow Wood		LS0WS45	LSRWS45	LSJWS45	LS8WS45
Cream Wood		LS0WS05	LSRWS05	LSJWS05	LS8WS05
Honey Wood		LS0WS15	LSRWS15	LSJWS15	LS8WS15
Vintage Wood		LS0WS25	LSRWS25	LSJWS25	LS8WS25
Coffee Wood		LS0WS35	LSRWS35	LSJWS35	LS8WS35

* Per ordini inferiori alle 15 lastre sarà addebitato il costo del pallet a Euro 80,00 netto. / The cost of the pallet, Euro 80,00 net, will be charged for orders less than 15 slabs. / Pour toutes commandes inférieures à 15 dalles, un cout de 80 Euro correspondant au cout de la palette sera ajouté. / Bei Abnahme einer Menge unter 15 Platten werden Euro 80,00 Netto für Verpackung/palette belastet.

wood



SNOW
Delta Warm 28
Delta Cold 29



TYPE 32

DESIGN DIEGO GRANDI

70/
71

 SLIMTECH

1

FORMATO

size / format / Formate

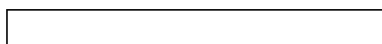

20x200cm / 8"x79"
slimtech 5plus

4

COLORI

colors / couleurs / Farben

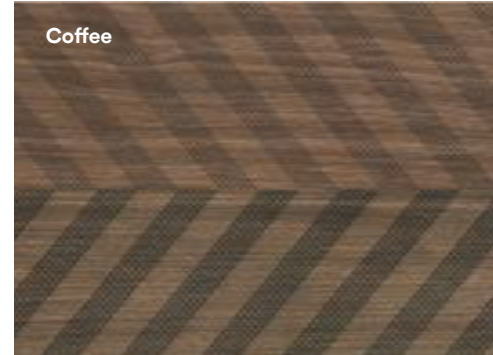
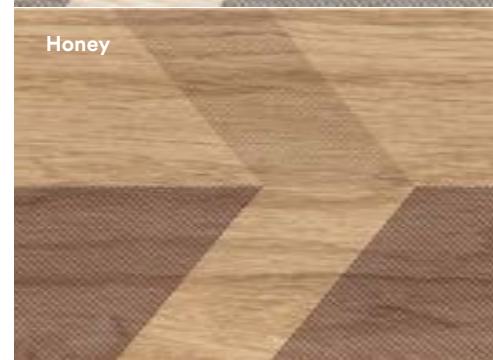





TYPE 32

SNOW

Delta Warm 28

Delta Cold 29



72/
73

wood



TYPE 32

VINTAGE

Alfa Cold 07

Delta Warm 26





**COFFEE**

Delta Cold 32

Delta Warm 25

**TYPE 32****HONEY**

Beta Warm 11

Delta Cold 30

Alfa Warm 03

Gamma Cold 22



TYPE 32

COLORI

colors / couleurs / farben

SNOW

ALFA

BETA

GAMMA

DELTA

05

13

21

29



COLD

04

12

20

28



WARM

HONEY

ALFA

BETA

GAMMA

DELTA

06

14

22

30



COLD

03

11

19

27



WARM

COLORI

colors / couleurs / farben

VINTAGE

ALFA

BETA

GAMMA

DELTA

07

15

23

31



COLD

02

10

18

26



WARM

COFFEE

ALFA

BETA

GAMMA

DELTA

08

16

24

32



COLD

01

09

17

25

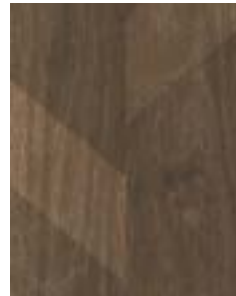

WARM

TYPE 32

COLORI

colors / couleurs / farben

SNOW



ALFA SNOW WARM 04
20X200CM / 8"X79"



BETA SNOW WARM 12
20X200CM / 8"X79"



GAMMA SNOW WARM 20
20X200CM / 8"X79"



DELTA SNOW WARM 28
20X200CM / 8"X79"



ALFA SNOW COLD 05
20X200CM / 8"X79"



BETA SNOW COLD 13
20X200CM / 8"X79"



GAMMA SNOW COLD 21
20X200CM / 8"X79"



DELTA SNOW COLD 29
20X200CM / 8"X79"



COLORI

colors / couleurs / farben

HONEY**ALFA HONEY WARM 03**
20X200CM / 8"X79"**BETA HONEY WARM 11**
20X200CM / 8"X79"**GAMMA HONEY WARM 19**
20X200CM / 8"X79"**DELTA HONEY WARM 27**
20X200CM / 8"X79"**ALFA HONEY COLD 06**
20X200CM / 8"X79"**BETA HONEY COLD 14**
20X200CM / 8"X79"**GAMMA HONEY COLD 22**
20X200CM / 8"X79"**DELTA HONEY COLD 30**
20X200CM / 8"X79"

TYPE 32

COLORI

colors / couleurs / farben

VINTAGE



ALFA VINTAGE WARM 02
20X200CM / 8"X79"



BETA VINTAGE WARM 10
20X200CM / 8"X79"



GAMMA VINTAGE WARM 18
20X200CM / 8"X79"

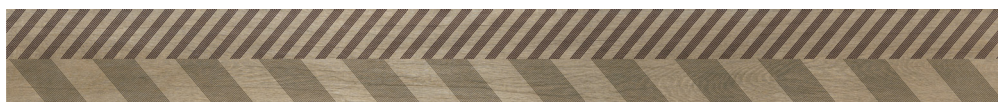

DELTA VINTAGE WARM 26
20X200CM / 8"X79"



ALFA VINTAGE COLD 07
20X200CM / 8"X79"



BETA VINTAGE COLD 15
20X200CM / 8"X79"

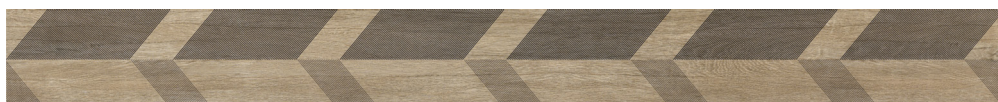

GAMMA VINTAGE COLD 23
20X200CM / 8"X79"

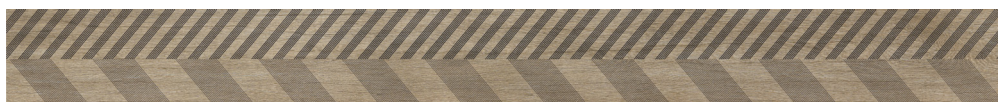

DELTA VINTAGE COLD 31
20X200CM / 8"X79"



COLORI

colors / couleurs / farben

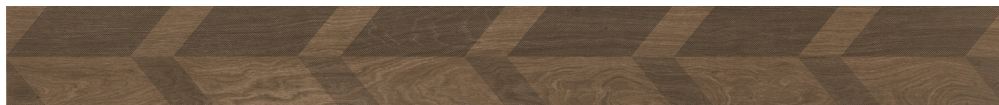
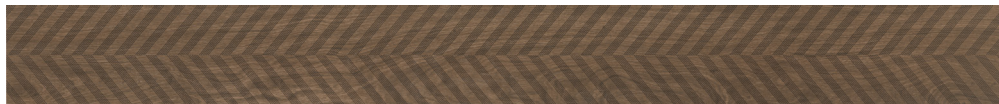
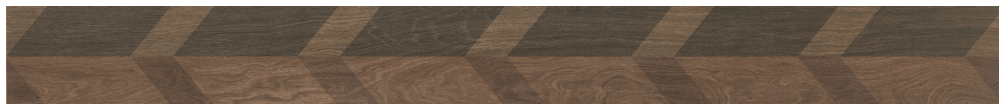
COFFEE**ALFA COFFEE WARM 01**
20X200CM / 8"X79"**BETA COFFEE WARM 09**
20X200CM / 8"X79"**GAMMA COFFEE WARM 17**
20X200CM / 8"X79"**DELTA COFFEE WARM 25**
20X200CM / 8"X79"**ALFA COFFEE COLD 08**
20X200CM / 8"X79"**BETA COFFEE COLD 16**
20X200CM / 8"X79"**GAMMA COFFEE COLD 24**
20X200CM / 8"X79"**DELTA COFFEE COLD 32**
20X200CM / 8"X79"

TYPE 32

HONEY

Beta Warm 11

Delta Cold 30

Alfa Warm 03

Gamma Cold 22



TYPE 32

GRES LAMINATO GL

Laminated porcelain GL / Grès laminé GL
Laminiertes Feinsteinzeug GL





Type 32 è un progetto per sua natura versatile, in grado di interagire con l'ambiente ed i suoi abitanti e di modificarsi nelle forme e nei colori. Come il legno, anche Type 32, nel registrare il passare del tempo, restituisce una superficie dall'aspetto vintage, un effetto "vissuto" tipico dei pavimenti legati alla nostra memoria. Questa peculiarità rende la collezione originale ed esclusiva, con una personalità irripetibile. In Type 32 i mutamenti rincorrono e ricordano il tempo trascorso.

FONDI

plain tiles / fonds / Unifliesen

ALFA WARM

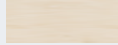
20x200cm
8"x79"

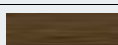
Snow		04 LSJTY04
Honey		03 LSJTY03
Vintage		02 LSJTY02
Coffee		01 LSJTY01

Type 32 is a design which, due to its versatile nature, is able to interact with the environment and its inhabitants, as well as change in terms of shapes and colors. Like aged wood, Type 32 also gives an area a vintage look, a "lived in" effect which is typical of floors with a touch of nostalgia. This peculiarity makes the collection unique and original, with a special personality. With Type 32 the changes take us back and remind us of times gone by.

Grâce à sa nature polyvalente, Type 32 est en mesure d'interagir avec l'environnement et ses habitants et de modifier ses propres formes et couleurs. Tel le bois sous l'effet du temps qui passe, Type 32 révèle une surface à l'aspect vintage, avec un effet de « vécu » caractéristique des sols liés à notre mémoire. Cette particularité en fait une collection originale et exclusive, dont la personnalité est incomparable. Avec Type 32, les changements recherchent et évoquent le temps passé.

Type 32 ist ein vielseitiges Projekt, das in der Lage ist, mit der Umwelt und ihren Bewohnern zu interagieren und sowohl Form als auch Farbe zu wechseln. So wie es bei Holz der Fall ist, hinterlässt das Vergehen der Zeit auch bei Type 32 einen Vintage-Look auf der Bodenoberfläche, eine "gelebte" Wirkung, die typisch für Fußböden unserer Erinnerungen ist. Dieser Charakterzug erweist sich als grundlegend für diese originale und exklusive Kollektion unwiderstehlicher Persönlichkeit. Bei Type 32 folgt und gedenkt Wandel der verstrichenen Zeit.

SPESSORE

Thickness / Epaisseur / Stärke

5,5 mm → slimtech 5plus



STONALIZZAZIONE

Shading / Denuançage / Spielfarbig

Informazioni tecniche per l'utilizzo pag. 402

Technical information for use.

Informations techniques pour l'utilisation.

Technische Zusammenarbeit.

Ideale per rivestimenti e per pavimenti in ambienti residenziali.

Suitable for wall coverings and floors in residential applications.

Idéal pour revêtements et sols pour locaux résidentiels privés.

Für Wand und Boden im Wohnbereich geeignet.

FUGA MINIMA CONSIGLIATA PER POSA IN INTERNO

Minimum suggested joint for indoor fixing
Joint minimum conseillé pour pose en intérieure
Empfohlene Fugenbreite fuer Innenbereich

PARETE / Wall / Mur / Wand

1 mm → slimtech 5plus

PAVIMENTO / Floor / Sol / Boden

1 mm → slimtech 5plus

IMBALLI

Packing / Emballage / Verpackung

pag. 434

BETA WARM	GAMMA WARM	DELTA WARM	ALFA COLD	BETA COLD	GAMMA COLD	DELTA COLD
20x200cm 8"x79"	20x200cm 8"x79"	20x200cm 8"x79"	20x200cm 8"x79"	20x200cm 8"x79"	20x200cm 8"x79"	20x200cm 8"x79"
12 LSJTY12	20 LSJTY20	28 LSJTY28	05 LSJTY05	13 LSJTY13	21 LSJTY21	29 LSJTY29
11 LSJTY11	19 LSJTY19	27 LSJTY27	06 LSJTY06	14 LSJTY14	22 LSJTY22	30 LSJTY30
10 LSJTY10	18 LSJTY18	26 LSJTY26	07 LSJTY07	15 LSJTY15	23 LSJTY23	31 LSJTY31
09 LSJTY09	17 LSJTY17	25 LSJTY25	08 LSJTY08	16 LSJTY16	24 LSJTY24	32 LSJTY32

stone



NATURALE

100x300cm / 39"x118"

100x100cm / 39"x39"



LAPPATA

50x100cm / 19¹/₂"x39"

4,9x100cm / 2"x39"



BASALTINA STONE PROJECT

86/87



5

FORMATI

sizes / formats / Formate



4,9x100cm / 2"x39"
slimtech 3mm
slimtech 3plus



50x50cm / 19¹/₂"x19¹/₂"
slimtech 3plus



50x100cm / 19¹/₂"x39"
slimtech 3mm
slimtech 3plus



100x100cm / 39"x39"
slimtech 3plus

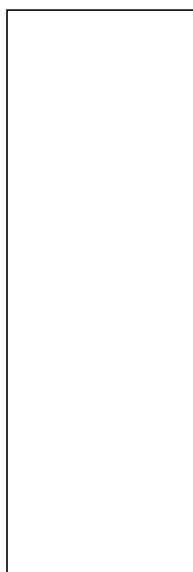

100x300cm / 39"x118"
slimtech 3mm
slimtech 3plus

4

COLORI

colors / couleurs / Farben

Sabbiata

Naturale

Stuccata

Lappata

BASALTINA STONE PROJECT



NATURALE

100x300cm / 39"x118"

100x100cm / 39"x39"

mosaico striscia
25x50cm / 10"x19^{1/2}"



LAPPATA

100x300cm / 39"x118"

50x50cm / 19^{1/2}"x19^{1/2}"









BASALTINA STONE PROJECT

STUCCATA

100x300cm / 39"x118"

100x100cm / 39"x39"

mosaico striscia
25x50cm / 10"x19^{1/2}"

mosaico listello
25x50cm / 10"x19^{1/2}"



NATURALE

50x100cm / 19^{1/2}"x39"

100x100cm / 39"x39"



BASALTINA STONE PROJECT

MOSAICI

mosaics / mosaïques / Mosaik

MOSAICO
QUADRO
sabbiaia
25x25cm /
10"x10"

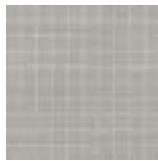

MOSAICO
MATTONE
sabbiaia
25x25cm /
10"x10"



MOSAICO
STRISCIA
sabbiaia
25x50cm /
10"x19 1/2"



MOSAICO
LISTELLO
sabbiaia
25x50cm /
10"x19 1/2"



MOSAICO
QUADRO
naturale
25x25cm /
10"x10"

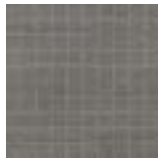

MOSAICO
MATTONE
naturale
25x25cm /
10"x10"



MOSAICO
STRISCIA
naturale
25x50cm /
10"x19 1/2"



MOSAICO
LISTELLO
naturale
25x50cm /
10"x19 1/2"



MOSAICO
QUADRO
stuccata
25x25cm /
10"x10"

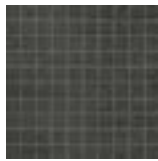

MOSAICO
MATTONE
stuccata
25x25cm /
10"x10"



MOSAICO
STRISCIA
stuccata
25x50cm /
10"x19 1/2"



MOSAICO
LISTELLO
stuccata
25x50cm /
10"x19 1/2"

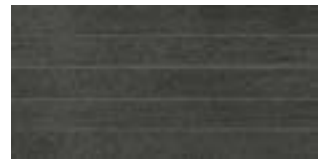

MOSAICO
QUADRO
lappata
25x25cm /
10"x10"

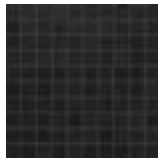

MOSAICO
MATTONE
lappata
25x25cm /
10"x10"

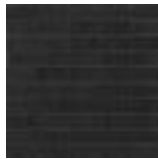

MOSAICO
STRISCIA
lappata
25x50cm /
10"x19 1/2"



MOSAICO
LISTELLO
lappata
25x50cm /
10"x19 1/2"



MOSAICI

mosaics / mosaïques / Mosaik

MOSAICO
INOX
sabbata
25x25cm /
10"x10"



MOSAICO
SATIN
sabbata
25x25cm /
10"x10"



MOSAICO
METAL
chiaro (naturale)
50x100cm /
19 1/2"x39"



MOSAICO
GLITTER
chiaro (sabbata)
50x100cm /
19 1/2"x39"



MOSAICO
INOX
naturale
25x25cm /
10"x10"



MOSAICO
SATIN
naturale
25x25cm /
10"x10"



MOSAICO
INOX
stuccata
25x25cm /
10"x10"

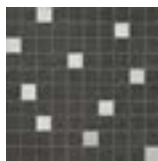

MOSAICO
PEARL
stuccata
25x25cm /
10"x10"

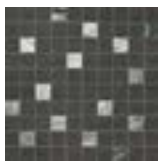

MOSAICO
METAL
scuro (lappata)
50x100cm /
19 1/2"x39"



MOSAICO
GLITTER
scuro (stuccata)
50x100cm /
19 1/2"x39"



MOSAICO
INOX
lappata
25x25cm /
10"x10"

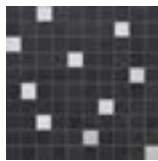

MOSAICO
PEARL
lappata
25x25cm /
10"x10"

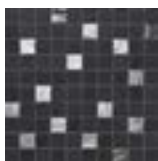

BASALTINA STONE PROJECT

SABBIATA

100x300cm / 39"x118"

60x120cm / 24"x48" (11mm)

mosaico mattone

25x50cm / 10"x19^{1/2}"



FONDI

plain tiles / fonds / Unifliesen

Sabbiata



Naturale



Stuccata



Lappata



MOSAICI

mosaics / mosaïques / Mosaik

Sabbiata



Naturale



Stuccata



Lappata



BASALTINA STONE PROJECT

GRES LAMINATO UGL

Laminated porcelain UGL / Grès laminé UGL
Laminiertes Feinsteinzeug UGL

SPESSORE

Thickness / Epaisseur / Stärke

3 mm → slimtech 3mm
3,5 mm → slimtech 3plus



STONALIZZAZIONE

Shading / Denuançage / Spielfarbig

DYNAMIC COEFFICIENT OF FRICTION ANSI A 137.1:2012

DCOF \geq 0.42 (3plus)

COEFFICIENTE DI ATTRITO DINAMICO B.C.R. TORTUS

$\mu > 0,40$ (3plus)

RESISTENZA ALLO SCIVOLAMENTO DIN 51130

Slip resistance / Résistance au glissement
Rutschfestigkeit

R9 (3plus)

FUGA MINIMA CONSIGLIATA PER POSA IN INTERNO

Minimum suggested joint for indoor fixing
Joint minimum conseillé pour pose en interieure
Empfohlene Fugenbreite fuer Innenbereich

PARETE / Wall / Mur / Wand

1 mm → slimtech 3mm - slimtech 3plus

PAVIMENTO / Floor / Sol / Boden

2 mm → slimtech 3plus

IMBALLI

Packing / Emballage / Verpackung

pag. 425

4,9x100cm 2"x39"	4,9x100cm 2"x39"	50x50cm 19 ^{1/2} "x19 ^{1/2} "	50x100cm 19 ^{1/2} "x39"	50x100cm 19 ^{1/2} "x39"	100x100cm 39"x39"	100x300cm* 39"x118"	100x300cm* 39"x118"
slimtech 3mm	slimtech 3plus	slimtech 3plus	slimtech 3mm	slimtech 3plus	slimtech 3plus	slimtech 3mm	slimtech 3plus
LSEBS00	LSEBS05	LSDBS05	LSBBS00	LSBBS05	LSCBS05	LSABS00	LSABS05
LSEBS10	LSEBS15	LSDBS15	LSBBS10	LSBBS15	LSCBS15	LSABS10	LSABS15
LSEBS20	LSEBS25	LSDBS25	LSBBS20	LSBBS25	LSCBS25	LSABS20	LSABS25
LSEBS30	LSEBS35	LSDBS35	LSBBS30	LSBBS35	LSCBS35	LSABS30	LSABS35

* Per ordini inferiori alle 5 lastre sarà addebitato il costo del pallet a Euro 80,00 netto. / The cost of the pallet, Euro 80,00 net, will be charged for orders less than 5 slabs. / Pour toutes commandes inférieures à 5 dalles, un cout de 80 Euro correspondant au cout de la palette sera ajouté. / Bei Abnahme einer Menge unter 5 Platten werden Euro 80,00 Netto für Verpackung/ palette belastet.

MOSAICO QUADRO	MOSAICO MATTONE	MOSAICO STRISCIA	MOSAICO LISTELLO	MOSAICO INOX	MOSAICO SATIN	MOSAICO PEARL	MOSAICO METAL	MOSAICO GLITTER
25x25cm 10"x10"	25x25cm 10"x10"	25x50cm 10"x19 ^{1/2} "	25x50cm 10"x19 ^{1/2} "	25x25cm 10"x10"	25x25cm 10"x10"	25x25cm 10"x10"	50x100cm 19 ^{1/2} "x39"	50x100cm 19 ^{1/2} "x39"
slimtech 3plus	slimtech 3plus	slimtech 3plus	slimtech 3plus	slimtech 3plus	slimtech 3plus	slimtech 3plus	slimtech 3mm	slimtech 3mm
LS9BS00	LS9BS10	LS9BS20	LS9BS30	LS9BS05	LS9BS15	-	-	LS9BS35
LS9BS01	LS9BS11	LS9BS21	LS9BS31	LS9BS06	LS9BS16	-	LS9BS37	-
LS9BS02	LS9BS12	LS9BS22	LS9BS32	LS9BS07	-	LS9BS17	-	LS9BS36
LS9BS03	LS9BS13	LS9BS23	LS9BS33	LS9BS08	-	LS9BS18	LS9BS38	-



NAIVE BLACK
100x300cm / 39"x118"



NAIVE

DESIGN PATRICK NORGUET

96/
97

 SLIMTECH

2

FORMATI

sizes / formats / Formate

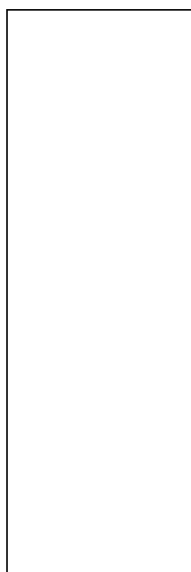

100x300cm / 39"x118"
slimtech 5plus

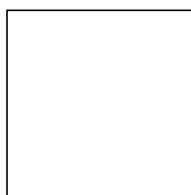

100x100cm / 39"x39"
slimtech 5plus

4

COLORI

colors / couleurs / Farben

Naive Blue

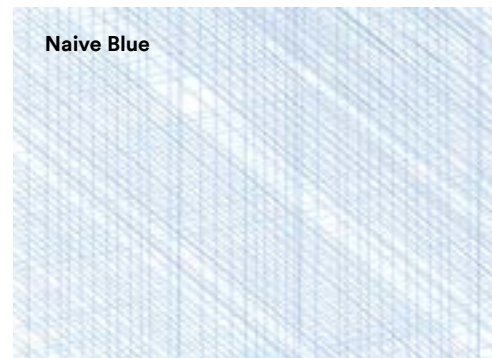

Naive Terra



Naive Grey



Naive Black

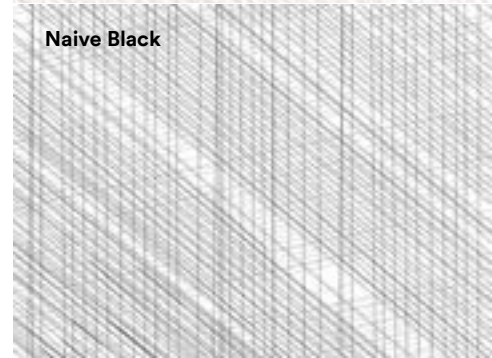



NAIVE

NAIVE GREY

100x300cm / 39"x118"

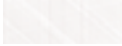

98/
99



NAIVE BLUE

100x300cm / 39"x118"







NAIVE

NAIVE TERRA
100x300cm / 39"x118"



NAIVE

NAIVE BLACK
100x300cm / 39"x118"

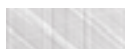

NAIVE

GRES LAMINATO UGL

Laminated porcelain UGL / Grès laminé UGL
Laminiertes Feinsteinzeug UGL



SPESSORE

Thickness / Epaisseur / Stärke

5,5 mm → slimtech 5plus



STONALIZZAZIONE

Shading / Denuançage / Spielfarbig

FUGA MINIMA CONSIGLIATA PER POSA IN INTERNO

Minimum suggested joint for indoor fixing
Joint minimum conseillé pour pose en interieure
Empfohlene Fugenbreite fuer Innenbereich

PARETE / Wall / Mur / Wand

1 mm → slimtech 5plus

PAVIMENTO / Floor / Sol / Boden

2 mm → slimtech 5plus

Ideale per rivestimenti e per pavimenti in ambienti residenziali e commerciale leggero.

Suitable for wall coverings and floors in both
residential and light-commercial applications.
Idéal pour revêtements et sols pour locaux
résidentiels privés et commercial léger.
Für Wand und Boden im Wohn- und leichte
kommerzielle Bereiche geeignet / Ideal para.

IMBALLI

Packing / Emballage / Verpackung
pag. 430

FONDI

plain tiles / fonds / Unifliesen

		100x100cm 39"x39"	*100x300cm 39"x118"
		slimtech 5plus	slimtech 5plus
Naive Blue		LSCNA10	LSANA10
Naive Terra		LSCNA30	LSANA30
Naive Grey		LSCNA20	LSANA20
Naive Black		LSCNA00	LSANA00

* Per ordini inferiori alle 5 lastre sarà addebitato il costo del pallet a Euro 80,00 netto. / The cost of the pallet, Euro 80,00 net, will be charged for orders less than 5 slabs. / Pour toutes commandes inférieures à 5 dalles, un cout de 80 Euro correspondant au cout de la palette sera ajouté. / Bei Abnahme einer Menge unter 5 Platten werden Euro 80,00 Netto für Verpackung/palette belastet.



LINE BLUE
100x300cm / 39"x118"



LINES

DESIGN PATRICK NORGUET

104/
105

 SLIMTECH

1

FORMATO

size / format / Format

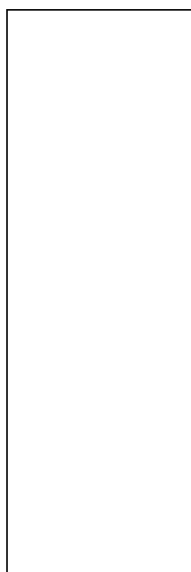

100x300cm / 39"x118"
slimtech 3plus

2

COLORI

colors / couleurs / Farben

Line Blue

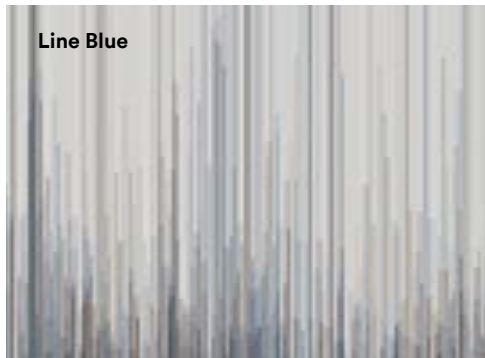

Line Grey







LINES

LINE GREY
100x300cm / 39"x118"





LINES

LINE BLUE
100x300cm / 39"x118"

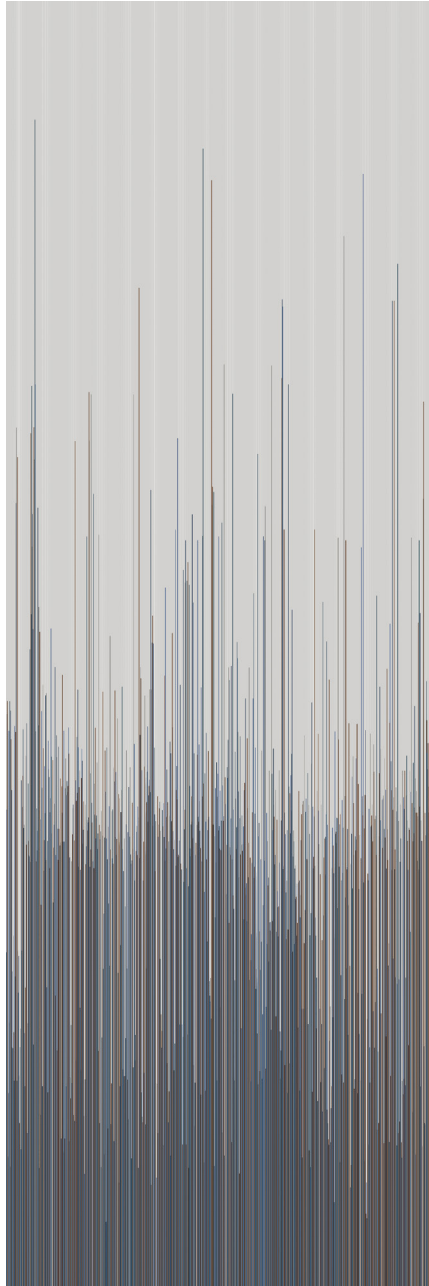

LINE GREY
100x300cm / 39"x118"

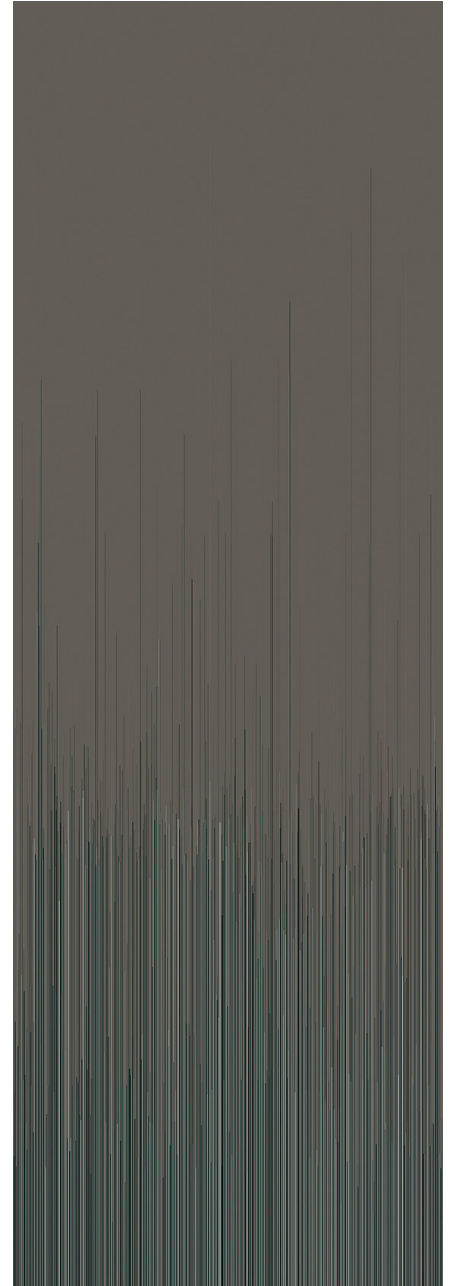

LINE BLUE
100x300cm / 39"x118"



LINES

LINE BLUE

100x300cm / 39"x118"



LINES

GRES LAMINATO UGL

Laminated porcelain UGL / Grès laminé UGL
Laminiertes Feinsteinzeug UGL

SPESSORE

Thickness / Epaisseur / Stärke

3,5 mm → slimtech 3plus



STONALIZZAZIONE

Shading / Denuançage / Spielfarbig

FUGA MINIMA CONSIGLIATA PER POSA IN INTERNO

Minimum suggested joint for indoor fixing
Joint minimum conseillé pour pose en interieure
Empfohlene Fugenbreite fuer Innenbereich

PARETE / Wall / Mur / Wand

1 mm → slimtech 3plus

IMBALLI

Packing / Emballage / Verpackung



pag. 429

FONDI

plain tiles / fonds / Unifliesen

*100×300cm
39"x118"

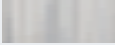
slimtech 3plus

Line Blue		LSALI06
Line Grey		LSALI26

* Per ordini inferiori alle 5 lastre sarà addebitato il costo del pallet a Euro 80,00 netto. / The cost of the pallet, Euro 80,00 net, will be charged for orders less than 5 slabs. / Pour toutes commandes inférieures à 5 dalles, un cout de 80 Euro correspondant au cout de la palette sera ajouté. / Bei Abnahme einer Menge unter 5 Platten werden Euro 80,00 Netto für Verpackung/palette belastet.



WAVE GREY
100x300cm / 39"x118"



WAVES

DESIGN PATRICK NORGUET

112/
113

 SLIMTECH

1

FORMATO

size / format / Format

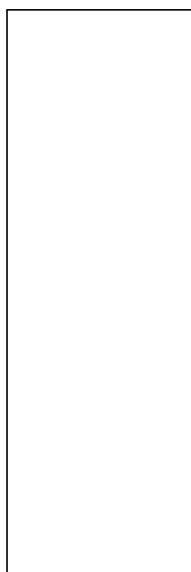

100x300cm / 39"x118"
slimtech 3plus

2

COLORI

colors / couleurs / Farben

Wave Blue

Wave Grey





WAVES

WAVE BLUE

100x300cm / 39"x118"



WAVE GREY

100x300cm / 39"x118"



WAVES

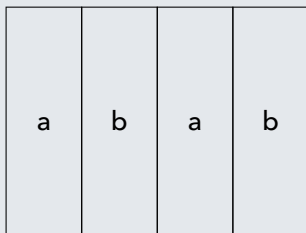

WAVE BLUE A
100x300cm / 39"x118"

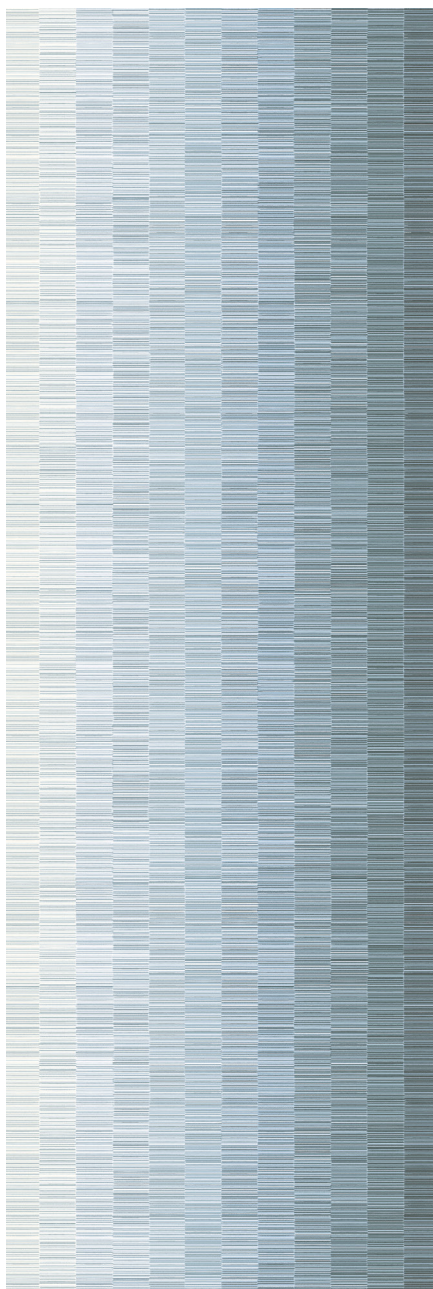

WAVE BLUE B
100x300cm / 39"x118"



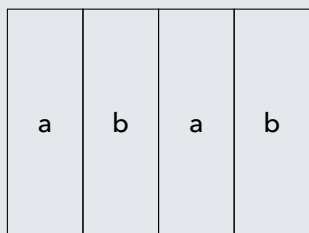

WAVE GREY A
100x300cm / 39"x118"

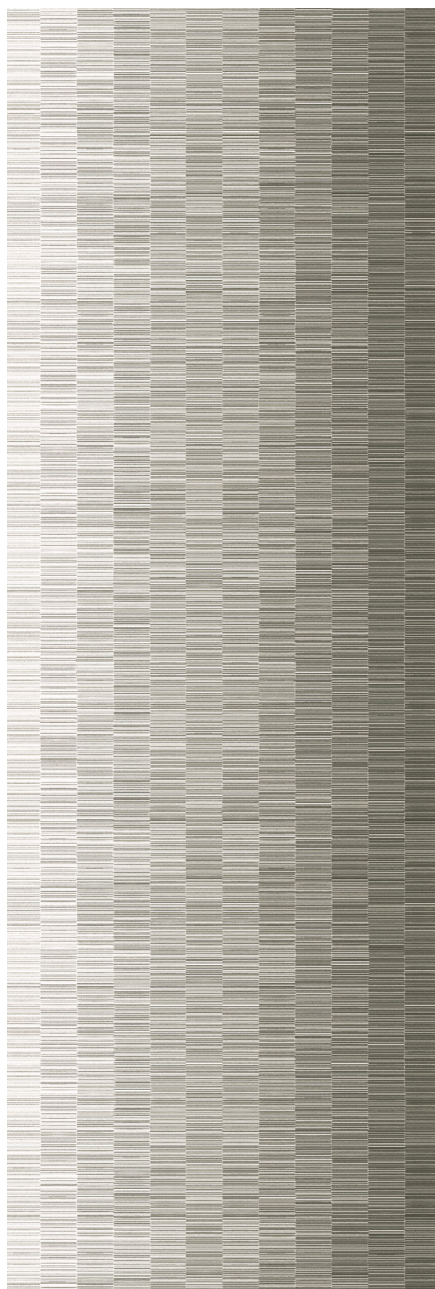

WAVE GREY B
100x300cm / 39"x118"



WAVES

WAVE GREY

100x300cm / 39"x118"



WAVES

GRES LAMINATO UGL

Laminated porcelain UGL / Grès laminé UGL
Laminiertes Feinsteinzeug UGL

SPESSORE

Thickness / Epaisseur / Stärke

3,5 mm → slimtech 3plus



STONALIZZAZIONE

Shading / Denuançage / Spielfarbig

FUGA MINIMA CONSIGLIATA PER POSA IN INTERNO

Minimum suggested joint for indoor fixing
Joint minimum conseillé pour pose en interieure
Empfohlene Fugenbreite fuer Innenbereich

PARETE / Wall / Mur / Wand

1 mm → slimtech 3plus

IMBALLI

Packing / Emballage / Verpackung

pag. 435

FONDI

plain tiles / fonds / Unifliesen

***100x300cm**
39"x118"

slimtech 3plus

Wave Blue A		LSAWA08
Wave Blue B		LSAWA09
Wave Grey A		LSAWA28
Wave Grey B		LSAWA29

* Per ordini inferiori alle 5 lastre sarà addebitato il costo del pallet a Euro 80,00 netto. / The cost of the pallet, Euro 80,00 net, will be charged for orders less than 5 slabs. / Pour toutes commandes inférieures à 5 dalles, un cout de 80 Euro correspondant au cout de la palette sera ajouté. / Bei Abnahme einer Menge unter 5 Platten werden Euro 80,00 Netto für Verpackung/ palette belastet.



shapes & colors

12,5x50cm / 5"x19^{1/2}"

PIXEL

HOK PRODUCT DESIGN

120/
121



3

FORMATI

sizes / formats / Formate



*12,5x50cm / 5"x19^{1/2}"
slimtech 3plus



*50x100cm / 19^{1/2}"x39"
slimtech 3plus

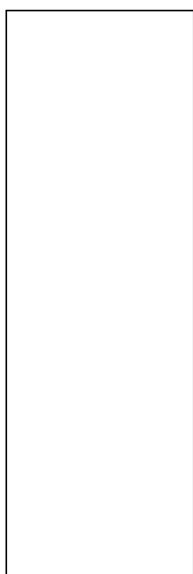

*100x300cm / 39"x118"
slimtech 3plus

*su richiesta
upon request /
sur demande /
auf Anfrage

9

COLORI

colors / couleurs / Farben

Orange

Red

Navy

Rust

Ocean

Lime

Emerald

Blue

Leaf

PIXEL

12,5x50cm / 5"x19 1/2"



PIXEL

DECORO REALIZZATO CON GRES LAMINATO UGL

Decor made with laminated porcelain UGL
 Décor réalisé avec grès laminé UGL
 Das Dekor ist aus hergestellert laminiertes Feinsteinzeug UGL

SPESSORE

Thickness / Epaisseur / Stärke

3,5 mm → slimtech 3plus



FUGA MINIMA CONSIGLIATA PER POSA IN INTERNO

Minimum suggested joint for indoor fixing
 Joint minimum conseillé pour pose en interieure
 Empfohlene Fugenbreite fuer Innenbereich

1 mm

Utilizzabile solo per rivestimenti in ambienti residenziali.

Suitable only for wall coverings in residential applications.
 Seulement pour revêtements pour locaux résidentiels privatifs.
 Nur für Wandbelege im Wohnbereich geeignet.

Informazioni tecniche per l'utilizzo pag. 402

Technical information for use.
 Informations techniques pour l'utilisation.
 Technische Zusammenarbeit.

IMBALLI

Packing / Emballage / Verpackung
 pag. 431



STONALIZZAZIONE

Shading / Denuançage / Spielfarbig

FONDI

plain tiles / fonds / Unifliesen

		12,5x50cm 5"x19 1/2"	50x100cm 19 1/2"x39"	100x300cm* 39"x118"
		slimtech 3plus	slimtech 3plus	slimtech 3plus
Orange		LS9PX60	LSBPX60	LSAPX60
Red		LS9PX70	LSBPX70	LSAPX70
Rust		LS9PX80	LSBPX80	LSAPX80
Lime		LS9PX30	LSBPX30	LSAPX30
Leaf		LS9PX20	LSBPX20	LSAPX20
Emerald		LS9PX10	LSBPX10	LSAPX10
Blue		LS9PX00	LSBPX00	LSAPX00
Ocean		LS9PX50	LSBPX50	LSAPX50
Navy		LS9PX40	LSBPX40	LSAPX40

* Per ordini inferiori alle 5 lastre sarà addebitato il costo del pallet a Euro 80,00 netto. / The cost of the pallet, Euro 80,00 net, will be charged for orders less than 5 slabs. / Pour toutes commandes inférieures à 5 dalles, un cout de 80 Euro correspondant au cout de la palette sera ajouté. / Bei Abnahme einer Menge unter 5 Platten werden Euro 80,00 Netto für Verpackung/palette belastet.



ettagono
L 50cm / 19^{1/2}"

triangolo
L 50cm / 19^{1/2}"

**6****FORMATI**

sizes / formats / Formate

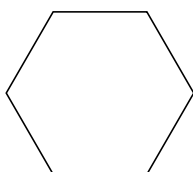

*ESAGONO

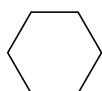
L 50cm / 19¹/₂"100x86,6cm / 39"x34¹/₈"

*ESAGONO

L 25cm / 10"

50x43,2cm / 19¹/₂"x17"

*ESAGONO

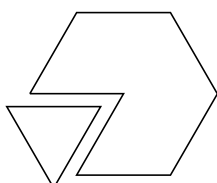
L 6,2cm / 2¹/₂"12,5x10,8cm / 5"x4¹/₄"

*ETTAGONO

L 50cm / 19¹/₂"100x86,6cm / 39"x34¹/₈"

*TRIANGOLO

L 50cm / 19¹/₂"

*ETTAGONO

L 25cm / 10"

50x43,2cm / 19¹/₂"x17"

*TRIANGOLO

L 25cm / 10"



*ETTAGONO

L 6,2cm / 2¹/₂"12,5x10,8cm / 5"x4¹/₄"

*TRIANGOLO

L 6,2cm / 2¹/₂"**DECORO REALIZZABILE CON LE SERIE:**

The decor can be made with the following collections: /

Décor réalisable avec les séries: /

Dekor realisierbar mit den Serien:

ABSOLUTE**BASALTINA STONE PROJECT****GOUACHE.10****RE-EVOLUTION****SHADE****TIMELESS MARBLE**

NEST

ettagono
L 25cm / 10"

triangolo
L 25cm / 10"



NEST

DECORO REALIZZATO CON GRES LAMINATO UGL

Decor made with laminated porcelain UGL
 Décor réalisé avec grès laminé UGL
 Das Dekor ist aus hergestellt laminiertes Feinsteinzeug UGL

SPESORE

Thickness / Epaisseur / Stärke

3,5 mm → slimtech 3plus

5,5 mm → slimtech 5plus

 SLIMTECH

FUGA MINIMA CONSIGLIATA PER POSA IN INTERNO

Minimum suggested joint for indoor fixing
 Joint minimum conseillé pour pose en enterieure
 Empfohlene Fugenbreite fuer Innenbereich

PARETE / Wall / Mur / Wand

1 mm → slimtech 3plus - slimtech 5plus

PAVIMENTO / Floor / Sol / Boden

2 mm → slimtech 3plus - slimtech 5plus

Il decoro ottenuto da Slimtech Absolute, Basaltina Stone Project, Gouache.10, RE-evolution, Shade, Timeless Marble è utilizzabile per pavimenti e rivestimenti (pag. 16).

The decors made using Slimtech Absolute, Basaltina Stone Project, Gouache.10, RE-evolution, Shade, Timeless Marble can be used for both floor and wall applications.

Les décors produit en utilisant Slimtech Absolute, Basaltina Stone Project, Gouache.10, RE-evolution, Shade, Timeless Marble sont utilisables au mur ainsi qu'au sol.

Dekor aus den Kollektionen Slimtech Absolute, Basaltina Stone Project, Gouache.10, RE-evolution, Shade, Timeless Marble ist für Wand und Boden geeignet.

I decori NEST sono venduti esclusivamente a scatola intera. All'interno delle scatole sono presenti pezzi dello stesso colore.

The NEST decors are sold only in full boxes. In each box there is only one color.

Les décors NEST sont vendus uniquement par boîte entière. Dans les boîtes sont présents des articles de la même couleur.

Die Dekore NEST werden ausschließlich in kompletten Kartoneinheiten verkauft. Die Kartons enthalten jeweils eine Farbe.

IMBALLI

Packing / Emballage / Verpackung
 pag. 430



LAPPATA

spina bsp
8,7x13,5x25,8cm / 3^{3/8}''x5^{3/8}''x10^{1/8}''

cuadra bsp plus
57,6cm / 22^{5/8}''

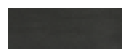

NATURALE

cuadra bsp plus
57,6cm / 22^{5/8}''



SABBIATA

cuadra bsp plus
57,6cm / 22^{5/8}''

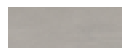

MAUK

DESIGN DIEGO GRANDI

128/
129

 SLIMTECH

3

FORMATI

sizes / formats / Formate

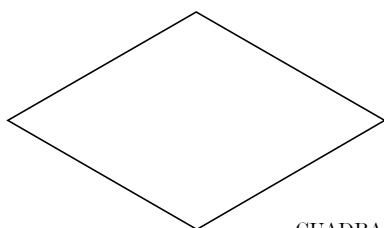

CUADRA
57,6cm / 22^{5/8}"
slimtech 3plus

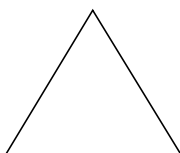

ESA
38,3cm / 15^{1/8}"
slimtech 3plus

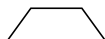

SPINA
base maggiore 25,8cm/10^{1/8}"
base minore 13,5cm/5^{3/8}"
lati 8,7cm/3^{3/8}"
slimtech 3mm

3

COLORI

colors / couleurs / Farben

Sabbiata

Naturale

Lappata





MAUK

SABBIATA
cuadra bsp plus
57,6cm / 22^{5/8}"



NATURALE
cuadra bsp plus
57,6cm / 22^{5/8}"



LAPPATA
cuadra bsp plus
57,6cm / 22^{5/8}"

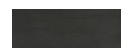

MAUK

SABBIATA

LAPPATA

spina bsp

8,7x13,5x25,8cm / 3³/₈"x5³/₈"x10¹/₈"



MAUK

GRES LAMINATO UGL

Laminated porcelain UGL / Grès laminé UGL
Laminiertes Feinsteinzeug UGL

SPESSORE

Thickness / Epaisseur / Stärke

3 mm → slimtech 3mm (spina)

3,5 mm → slimtech 3plus (cuadra - esa)

 SLIMTECH



STONALIZZAZIONE

Shading / Denuançage / Spielfarbig

FUGA MINIMA CONSIGLIATA PER POSA IN INTERNO

Minimum suggested joint for indoor fixing
Joint minimum conseillé pour pose en interieure
Empfohlene Fugenbreite fuer Innenbereich

PARETE / Wall / Mur / Wand

1 mm → slimtech 3mm - slimtech 3plus

PAVIMENTO / Floor / Sol / Boden

2 mm → slimtech 3plus

IMBALLI

Packing / Emballage / Verpackung

pag. 429

FONDI

plain tiles / fonds / Unifliesen

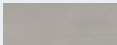
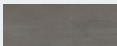
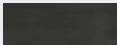
		CUADRA	ESA	SPINA
		57,6cm 22 ^{5/8"}	38,3cm 15 ^{1/8"}	8,7×13,5×25,8cm 3 ^{3/8"} ×5 ^{3/8"} ×10 ^{1/8"}
		slimtech 3plus	slimtech 3plus	slimtech 3mm
Sabbiata		LS9MK05	-	LS9MK01
Naturale		LS9MK06	LS9MK04	-
Lappata		LS9MK07	LS9MK03	LS9MK00



ELEPHOUNTAIN
BY CIBICWORKSHOP

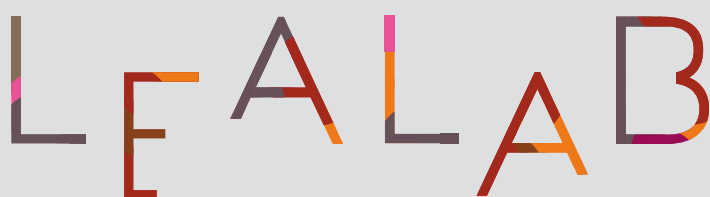

CAMPARITIVO - TRIENNALE DI MILANO

The logo for SLIMTECH features the word "SLIMTECH" in a bold, black, sans-serif font. The letter "S" is enclosed within a red circle that has a horizontal line passing through its center.The logo for LEALAB consists of the word "LEALAB" in a stylized, multi-colored font. Each letter is composed of several overlapping, semi-transparent shapes in shades of red, orange, yellow, and purple, giving it a vibrant, layered appearance.

Con LeaLab il gres laminato Slimtech diventa materiale mutante in grado di rispondere ad esigenze progettuali inaspettate e sorprendenti. La competenza tecnica di Lea Ceramiche e la sua naturale attitudine a produrre prodotti di qualità, costituiscono assoluta garanzia per supportare, in ogni sua fase, qualsiasi progetto in architettura, come nel residenziale. LeaLab rappresenta l'avanguardia nella personalizzazione del prodotto ceramico. Per ogni informazione: www.leaceramiche.com.

With Lealab, Slimtech laminated porcelain stoneware becomes a material that transforms to suit the needs of the most unexpected and surprising project requirements. Lea Ceramiche's technical skills and its natural penchant for producing high quality products are an absolute guarantee of its ability to support, at every stage, any architectural or residential project. LeaLab is at the forefront in the personalization of ceramic products. For more informations please visit www.leaceramiche.com.

Avec LeaLab, le grès laminé Slimtech devient un matériau changeant en mesure de répondre à des exigences de projet inattendues et étonnantes. La compétence technique de Lea Ceramiche et sa propension naturelle à fabriquer des produits de qualité constituent une garantie absolue pour assumer n'importe quelle phase d'un projet, aussi bien en architecture que dans le domaine résidentiel. LeaLab représente l'avant-garde de la personnalisation du produit en céramique. Pour toute information : www.leaceramiche.com.

Mit LeaLab wird das laminierte Feinsteinzeug Slimtech zu einem mutierenden Material, in der Lage den unerwarteten und überraschenden Designanforderungen entgegen zu kommen. Die technische Kompetenz von Lea Ceramiche und ihre natürliche Fähigkeit, qualitativ hochwertige Produkte herzustellen, bilden eine absolute Garantie, um jedes architektonische Projekt in jeder hase, wie im Wohnbereich, zu unterstützen. LeaLab steht für den Fortschritt bei der Personalisierung von keramischen Produkten. Für weitere Informationen: www.leaceramiche.com.

DESTINAZIONI D'USO

intended uses
destinations d'usage
anwendungen





Prodotti con finiture particolari possono prevedere limitazioni nelle destinazioni d'uso. Verificare nei singoli cataloghi di collezione.

Products with special finishes can have limitations depending on their area of application. Refer to specific collection catalogues.

Les produits avec des finitions particulières peuvent prévoir des limites d'application. Contrôler dans chaque catalogue de la collection.

Für Produkte mit besonderem Finish können endungseinschränkungen gelten. Bitte in den einzelnen Katalogen der Kollektionen nachprüfen.

POSA A PAVIMENTO FLOOR INSTALLATION POSE AU SOL FUSSBODENVERLEGUNG			POSA A PARETE WALL INSTALLATION POSE AU MUR WANDVERLEGUNG								
IN INTERNO			IN ESTERNO								
<p>Situazioni applicative sia per interventi di NUOVA COSTRUZIONE che di RISTRUTTURAZIONI con posa in sovrapposizione a pavimenti preesistenti.</p>			<p>Situazioni applicative sia per interventi di NUOVA COSTRUZIONE che di RISTRUTTURAZIONI con posa in sovrapposizione a rivestimenti preesistenti.</p>								
<p>RESIDENZIALE (cucine, bagni, living, aree comuni condominiali ed ogni altro ambiente di uso residenziale). slimtech 3plus slimtech 5plus</p>			<p>COMMERCIALE LEGGERO (uffici, uffici aperti al pubblico, sale d'attesa, negozi, bagni, sale di ristoranti, autosaloni, bar, cinema, ambulatori/cliniche). slimtech 3plus slimtech 5plus</p>			<p>COMMERCIALE INTENSIVO (aree comuni di centri commerciali, hall di alberghi, mense, fast food, discoteche, ospedali) ad esclusione di zone sottoposte al passaggio di carichi pesanti concentrati (ad es. carrelli a ruote dure). slimtech 5plus</p>			<p>A condizione che le superfici siano coperte (es. loggie, balconi coperti, ecc.) e perfettamente impermeabilizzate. Si consiglia l'utilizzo di formati non superiori a 50x50 cm. slimtech 3plus slimtech 5plus</p>		
<p>INTERIORS</p>			<p>EXTERIORS</p>								
<p>For NEW BUILDINGS and REFURBISHING, for installation on pre-existing floors.</p>			<p>For NEW BUILDINGS and REFURBISHING, for installation on pre-existing walls.</p>								
<p>RESIDENTIAL (kitchens, bathrooms, living rooms, common apartment block areas and any other residential environment). slimtech 3plus slimtech 5plus</p>			<p>LIGHT COMMERCIAL (offices, offices open to the general public, waiting rooms, shops, bathrooms, restaurant dining rooms, car showrooms, bars, cinemas, surgeries/clinics). slimtech 3plus slimtech 5plus</p>			<p>INTENSIVE COMMERCIAL (common areas of shopping centres, hotel halls, canteens, fast food restaurants, dance clubs, hospitals) with the exception of areas subject to heavy concentrated loads (e.g. trolleys with hard wheels). slimtech 5plus</p>			<p>Upon condition that surfaces are sheltered (e.g. loggias, covered balconies, etc.) and made totally impervious. The use of sizes that are not larger than 50x50cm is recommended. slimtech 3plus slimtech 5plus</p>		
<p>EN INTÉRIEUR</p>			<p>EN EXTÉRIEUR</p>								
<p>Application dans des NOUVELLES CONSTRUCTIONS ou des RESTRUCTURATIONS, avec pose sur des sols préexistants.</p>			<p>Application dans des NOUVELLES CONSTRUCTIONS ou des RESTRUCTURATIONS, avec pose sur des supports préexistants.</p>								
<p>RÉSIDENTIEL (cuisines, salles de bains, salles de séjour, zones de copropriété collectives et tout autre espace à usage résidentiel). slimtech 3plus slimtech 5plus</p>			<p>COMMERCIAL LÉGER (bureaux, bureaux ouverts au public, salles d'attente, magasins, salles de bains, salles de restaurants, salons automobiles, bars, cinémas, dispensaires/cliniques). slimtech 3plus slimtech 5plus</p>			<p>COMMERCIAL INTENSIF (zones communes de centres commerciaux, halls d'hôtels, cantines, fast-foods, discothèques, hôpitaux, sauf les zones soumises au passage de charges lourdes concentrées (ex. : chariots à roues dures). slimtech 5plus</p>			<p>À condition que les surfaces soient couvertes (loggias, balcons couverts, etc.) et parfaitement imperméabilisées. Il est conseillé d'utiliser des formats non supérieurs à 50x50 cm. slimtech 3plus slimtech 5plus</p>		
<p>INNENBEREICH</p>			<p>AUSSENBEREICH</p>								
<p>Anwendungslösungen sowohl für NEUBAUTEN als auch für RENOVIERUNGEN mit Verlegung auf vorhandenen Bodenbelägen.</p>			<p>Anwendungslösungen sowohl für NEUBAUTEN als auch für RENOVIERUNGEN mit Verlegung auf vorhandenen Wandverkleidungen.</p>								
<p>WOHNBEREICHE (Küchen, Badezimmer, Wohnzimmer, Gemeinschaftsflächen in Mehrfamilienhäusern und alle sonstigen Wohnbereiche). slimtech 3plus slimtech 5plus</p>			<p>LEICHTE GEWERBLICHE ANWENDUNGEN (Büroräume, öffentliche Büros, Wartezimmer, Geschäfte, Toiletten, Gaststätten, Autohäuser, Cafés, Kinos, Praxen/Kliniken). slimtech 3plus slimtech 5plus</p>			<p>INTENSIVE GEWERBLICHE ANWENDUNGEN (gemeinschaftsbereiche in einkaufszentren, hotelhallen, kantinen, fastfood-restaurants, diskotheken, krankenhäuser), mit ausnahme von bereichen mit schwerlastverkehr (z.b. stapler mit hartgummirädern). slimtech 5plus</p>			<p>Die Verlegung in Außenbereichen ist möglich, wenn die Oberflächen überdacht und vollkommen abgedichtet sind (überdachte Balkons, Veranden, usw.). Es sollten keine größeren Formate als 50x50 cm verwendet werden. slimtech 3plus slimtech 5plus</p>		
<p>INTERIORS</p>			<p>EXTERIORS</p>								
<p>EN INTÉRIEUR</p>			<p>EN EXTÉRIEUR</p>								
<p>INNENBEREICH</p>			<p>AUSSENBEREICH</p>								

			DESTINAZIONI SPECIALI SPECIAL USES UTILISATIONS SPÉCIALES SPEZIELLE VERWENDUNGSZWECKE							
	IN ESTERNO			FACCIAE VENTILATE		RIVESTIMENTI TERMICI A CAPPOTTO		RIVESTIMENTI VASCHE E PISCINE		SUPERFICI DA RIVESTIRE NEL SETTORE DELL'ARREDAMENTO
Qualunque ambiente residenziale e commerciale, in situazioni dove si devono praticare fori e/o tagli interni.	In situazioni dove non si devono praticare fori e/o tagli interni e con formati fino a 100x100 cm.	In situazioni dove si devono praticare fori e/o tagli interni e/o per formati grandi.	In funzione delle specifiche del progetto, in abbinamento a sistemi costruttivi indicati da Panariagroup e approvati dalla Direzione Lavori.	slimtech 3plus slimtech 5plus	slimtech 3mm* slimtech 3plus slimtech 5plus	* In situazioni dove non si devono praticare fori e/o tagli interni e con formati fino a 100x100 cm.	slimtech 3plus slimtech 5plus	slimtech 3mm slimtech 3plus slimtech 5plus		
slimtech 3plus slimtech 5plus	slimtech 3mm slimtech 3plus slimtech 5plus	slimtech 3plus slimtech 5plus								
	EXTERIORS			VENTILATED FACADES	THERMAL INSULATION SYSTEMS		POOL AND SWIMMING POOL TILING		FOR FURNITURE SURFACES	
Any residential and commercial environment, in situations where holes and/or cuts are necessary.	In situations where holes and/or cuts are not necessary and with sizes up to 100 x 100 cm.	In situations where holes and/or cuts are necessary and/or for large sizes.	Depending on project specifications and in combination with the construction systems recommended by Panariagroup and approved by the Installation Supervisor.	slimtech 3plus slimtech 5plus	slimtech 3mm* slimtech 3plus slimtech 5plus	* In situations where holes and/or cuts are not necessary and with sizes up to 100 x 100 cm.	slimtech 3plus slimtech 5plus	slimtech 3mm slimtech 3plus slimtech 5plus		
slimtech 3plus slimtech 5plus	slimtech 3mm slimtech 3plus slimtech 5plus	slimtech 3plus slimtech 5plus								
	EN EXTÉRIEUR			FAÇADES VENTILÉES	REVÊTEMENTS THERMIQUES À MUR-MANTEAU		REVÊTEMENTS BAIGNOIRES ET PISCINES		SURFACES À REVÊTIR DANS LE SECTEUR DE LA DÉCORATION	
Tout espace résidentiel et commercial, dans des endroits où il est nécessaire d'effectuer des trous et/ou des découpes internes.	Dans les situations où il ne faut pas percer de trous ni pratiquer de découpes internes et avec des formats jusqu'à 100x100 cm.	Dans les situations où il faut percer des trous ou pratiquer des découpes internes ou pour de grands formats.	En fonction des caractéristiques du projet et en combinaison avec les systèmes de construction indiqués par Panariagroup et approuvés par les maîtres d'oeuvre.	slimtech 3plus slimtech 5plus	slimtech 3mm* slimtech 3plus slimtech 5plus	* Dans les situations où il ne faut pas percer de trous ni pratiquer de découpes internes et avec des formats jusqu'à 100x100 cm.	slimtech 3plus slimtech 5plus	slimtech 3mm slimtech 3plus slimtech 5plus		
slimtech 3plus slimtech 5plus	slimtech 3mm slimtech 3plus slimtech 5plus	slimtech 3plus slimtech 5plus								
	AUSSENBEREICH			HINTERLÜFTETE FASSADEN	WÄRMEDÄMMVERBUND-SYSTEME		VERKLEIDUNG VON BECKEN UND SCHWIMMBECKEN		FLÄCHEN, DIE IM RAHMEN DER INNENEINRICHTUNG VERKLEIDET WERDEN	
Alle Wohn- und Gewerbebereiche, in Situationen, die Bohrungen und/oder Innenschnitte verlangen.	In Situationen, in denen keine internen Bohrungen und/oder Schnitte gefertigt werden müssen und mit Formaten bis 100x100 cm.	In Situationen, in denen interne Bohrungen und/oder Schnitte gefertigt werden müssen und/oder für Großformate.	In Funktion der Projektangaben und in Kombination mit Konstruktionssystemen, die Panariagroup vorgibt und die Arbeitsleitung genehmigt.	slimtech 3plus slimtech 5plus	slimtech 3mm* slimtech 3plus slimtech 5plus	* In Situationen, in denen keine internen Bohrungen und/oder Schnitte gefertigt werden müssen und mit Formaten bis 100x100 cm.	slimtech 3plus slimtech 5plus	slimtech 3mm slimtech 3plus slimtech 5plus		
slimtech 3plus slimtech 5plus	slimtech 3mm slimtech 3plus slimtech 5plus	slimtech 3plus slimtech 5plus								

Sperimentazione, design, ricerca, tecnologia, qualità: questi i valori fondamentali di Lea Ceramiche. La ricerca di soluzioni d'avanguardia è una componente strategica della produzione di Lea Ceramiche e rappresenta da sempre un valore distintivo dell'azienda. Le collezioni Lea Ceramiche sono particolarmente riconoscibili per la spiccata impronta stilistica e l'elevato contenuto tecnologico e di ricerca.

Experimentation, design, research, technology, quality: these are Lea Ceramiche's fundamental values. The search for cutting edge solutions is a strategic component of Lea Ceramiche's manufacturing and has always been one of the values that sets the company apart. Lea Ceramiche's collections are particularly recognizable for their unique style and their high level of technology and research.

Expérimentation, design, recherche, technologie et qualité sont les valeurs fondamentales de Lea Ceramiche. La recherche de solutions à l'avant-garde, qui permet depuis toujours à la société de se différencier des autres, est une étape stratégique de la production chez Lea Ceramiche. Les collections Lea Ceramiche possèdent cette touche de style unique et canalisent dans chaque produit une haute concentration de technologie et de recherche, se distinguant ainsi de toutes autres gammes.

Forschung, Design, Technologie und Qualität: das sind die Grundwerte von Lea Ceramiche. Die Suche nach fortschrittlichen Lösungen ist eine strategische Komponente der Produktion von Lea Ceramiche und zeichnet seit jeher das Unternehmen aus. Lea Ceramiche Kollektionen sind besonders erkennbar dank ihrer unverwechselbaren stilistischen Prägung und dem hohen Gehalt an High-Tech und Forschung.

142
154
170
182
192
200
208
220
234
244
254
264
270
284
294
304
314
320
328
332
346
354
360

trame
district
metropolis
makò
stoneclay / home
block / home

contemporary

waterfall
cliffstone
nova
basaltina stone project
tecnoquartz
outdoor

stone

dreaming

marble

bio recover
bio lumber
bio timber
bio plank
sunrise / home

wood

city
goccia / monoporosa
progetto L14 / monoporosa

shapes & colors

link / percorsi tattili
system L2 / 20mm













GRES AND MORE

GRES PORCELLANATO - MONOPOROSA

Full-body porcelain - White body tiles /
Grès Cérame pleine masse - Monocuisson /
Vollgemischtes Durchgefärbtes Feinsteinzeug /







FORMATI (CM)

Sizes - Formats - Formate

	(rett) BORDO RETTIFICATO - Edge Rectified - Bord Rectifié - Fliesenrand Rektifiziertes												
													
	20x180	60x120	30x120	20x120	90x90	60x90	45x90	30x90	75x75	73x73	60x60	40x60	30x60
Basaltina Stone P.		•									•		•
Bio Lumber			•	•									
Bio Plank				•									
Bio Recover	•												
Bio Timber				•									
Block home											•		
City													•
Cliffstone		•			•	•					•	•	•
District					•		•				•		•
Dreaming									•	•	•		•
Goccia monoporosa													
Link percorsi tattili													
Makò											•		•
Metropolis					•		•				•		•
Nova		•	•								•		•
Outdoor													
Progetto L14 monoporosa													
Stoneclay home											•		•
Sunrise home													
System L2 20mm			•				•				•		
Tecnoquartz											•	•	•
Trame					•			•					
Waterfall		•			•		•				•		•

FORMATI SPECIALI

special sizes / formats spéciaux / Sonderformate

	(rett) BORDO RETTIFICATO - Edge Rectified - Bord Rectifié - Fliesenrand Rektifiziertes						
							
	GRAMMA 72 49,8x16,9	GRAMMA 66 16,9x39,2	GRAMMA 16 19,5x9,7	GRAMMA 38 9,7x39,2	ESA 19,5x33,8	LISTELLO 5x45	CUADRA 11,2x9,7
Trame		•		•	•	•	•
Waterfall	•	•	•				

contemporary



CANVAS MORO
90x90cm / 36"x36"

ROLLER



CANVAS MORO
gramma 66 dx e sx - esa

ROLLER



PLASTER ARGILLA
gramma 66 sx

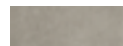

MATTER LINO
gramma 66 dx



CANVAS MORO
esa



TRAME

142/
143
PROTECT
 ANTIBATTERICO - ANTIMICROBIAL

8

FORMATI

sizes / formats / Formate

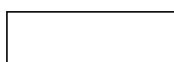

30x90 cm / 12"x36" rett

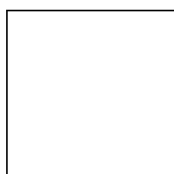

90x90cm / 36"x36" rett

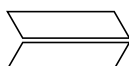
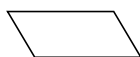
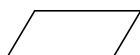
 gramma 38
 9,7x39,2 cm / 3³/₄"x15³/₈" rett

 gramma 66 sx
 16,9x39,2 cm / 6⁵/₈"x15³/₈" rett

 gramma 66 dx
 16,9x39,2 cm / 6⁵/₈"x15³/₈" rett

 cuadra
 11,2x9,7 cm / 4³/₈"x3³/₄" rett

 esa
 19,5x33,8 cm / 7⁵/₈"x13³/₈" rett

 listello
 5x45 cm / 2"x18" rett

3

FINITURE

finishes / surfaces / Oberfläche

PLASTER
MATTER
CANVAS

6

COLORI

colors / couleurs / Farben

Plaster Lino	Matter Lino	Canvas Lino	Plaster Lino	Matter Lino	Canvas Lino
Plaster Corda	Matter Corda	Canvas Corda	Plaster Corda	Matter Corda	Canvas Corda
Plaster Tortora	Matter Tortora	Canvas Tortora	Plaster Tabacco	Matter Tabacco	Canvas Tabacco
Plaster Moro	Matter Moro	Canvas Moro	Plaster Argilla	Matter Argilla	Canvas Argilla

contemporary

TRAME

MATTER CORDA
90x90cm / 36"x36"

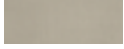

CANVAS TORTORA
90x90cm / 36"x36"

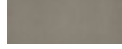



PLASTER LINO
90x90cm / 36"x36"



contemporary



TRAME

CHEVRON

MATTER MORO
gramma 38



MATTER ARGILLA
gramma 38



ARGILLA
cube



PLASTER ARGILLA
90x90cm / 36"x36"





CANVAS MORO
90x90cm / 36"x36"



contemporary



TRAME

MATTER ARGILLA
90x90cm / 36"x36"



148/
149



ROLLER

CANVAS MORO
gramma 66 dx e sx
esa



TRAME

MOSAICI

mosaics / mosaïques / Mosaik

FORMATI SPECIALI

special sizes / formats spéciaux / Sonderformate

ARROW
16,9x39,6 cm / 6^{5/8}"x15^{1/2}"

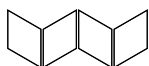

CUBE
39,6x39,6 cm / 15^{1/2}"x15^{1/2}"

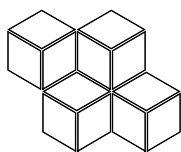

LEAF
40x34 cm / 16"x13^{3/8}"

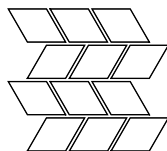

JEWEL
29,7x34 cm / 11^{3/4}"x13^{3/8}"

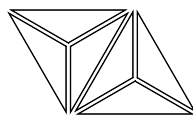

ESA*
19,5x33,8 cm / 7^{5/8}"x13^{3/8}"



GRAMMA 66 SX*
16,9x39,2 cm / 6^{5/8}"x15^{3/8}"



GRAMMA 66 DX*
16,9x39,2 cm / 6^{5/8}"x15^{3/8}"



CUADRA*
11,2x9,7 cm / 4^{3/8}"x3^{3/4}"



GRAMMA 38*
9,7x39,2 cm / 3^{3/4}"x15^{3/8}"

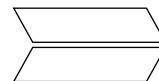

LISTELLO*
5x45 cm / 2"x18"



* disponibile su tutti i colori della serie / available in all colors of the series / disponible sur toutes les couleurs de la série / Erhältlich in allen Farben der Serie

ARROW

disponibile su tutti i colori / superfici (18 elementi)
available in all colors / surfaces (18 items) /
disponible sur toutes les couleurs / surfaces (18 éléments) /
Erhältlich für alle Farben / Oberflächen (18 Elemente)

CUBE

disponibile su tutti i colori multisuperficie (6 elementi)
available in all multi-surface colors (6 items) /
disponible sur toutes les couleurs multi-surface (6 éléments) /
Erhältlich für alle Farben und verschiedene Oberflächen (6 Elemente)

LEAF / JEWEL

versione chiara e versione scura multisuperficie (2 elementi)
multi-surface light and dark versions (2 items) /
version claire et version foncée multi-surface (2 éléments) /
Helle und dunkle Version verschiedener Oberflächen (2 Elemente)

MOSAICI

mosaics / mosaïques / Mosaik

		LINO	CORDA	TABACCO	ARGILLA	TORTORA	MORO	CHIARO	SCURO
arrow 16,9x39,6 cm 6 ^{5/8} "x15 ^{1/2} "	PLASTER	LGAT5P1	LGAT5P2	LGAT5P3	LGAT5P4	LGAT5P6	LGAT5P6	-	-
	MATTER	LGAT5M1	LGAT5M2	LGAT5M3	LGAT5M4	LGAT5M6	LGAT5M6	-	-
	CANVAS	LGAT5C1	LGAT5C2	LGAT5C3	LGAT5C4	LGAT5C6	LGAT5C6	-	-
cube 39,6x39,6 cm 15 ^{1/2} "x15 ^{1/2} "	TRIMATERICO	LGCT510	LGCT520	LGCT530	LGCT540	LGCT550	LGCT560	-	-
leaf 40x34 cm 16"x13 ^{3/8} "	TRIMATERICO	-	-	-	-	-	-	LG9T5LC	LG9T5LS
jewel 29,7x34 cm 11 ^{3/4} "x13 ^{3/8} "	TRIMATERICO	-	-	-	-	-	-	LG9T5JC	LG9T5JS

COMPOSIZIONI A MODULI SU RETE

mesh-mounted tile layouts / compositions en modules
sur filet / Modul-Kompositionen auf Netz

COMPOSIZIONI A MODULI SFUSI

tile layouts in loose modules / compositions en modules en vrac /
Kompositionen mit Einzelmodulen

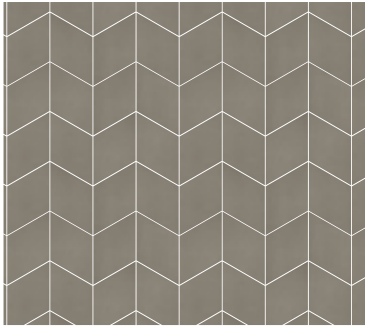
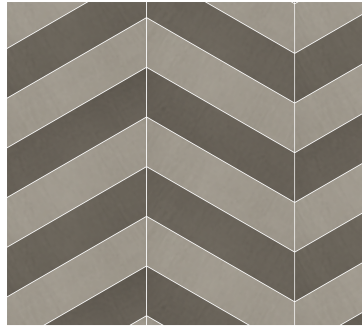
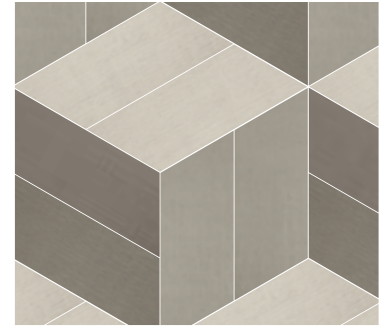
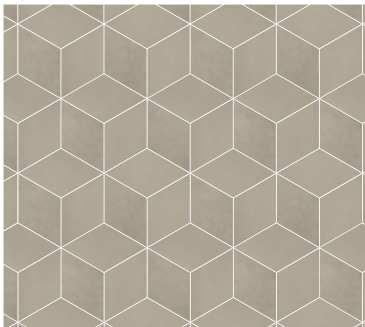
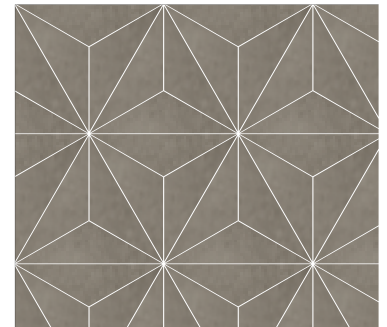
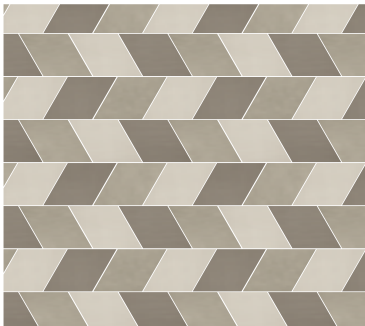
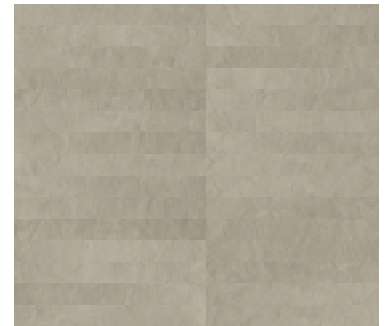
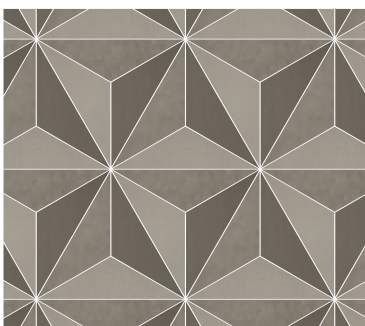
**ARROW****CHEVRON** (GRAMMA 38)**TWIST** (GRAMMA 66 SX)**CUBE****ROLLER** (GRAMMA 66 DX e SX + ESA)**JEWEL** (ESA)**LEAF****BOLT** (LISTELLO)**GRID** (LISTELLO)**JEWEL****WALL** (LISTELLO)

TRAME

MATTER LINO

90x90cm / 36"x36"



JEWEL SCURO

29,7x34cm / 11³/₄"x13³/₈"



PEZZI SPECIALI

trims / pièces spéciales / Formstücke

		LINO	CORDA	TABACCO	ARGILLA	TORTORA	MORO
	battiscopa 8x90cm / 3 ¹ / ₈ "x36" rett						
	PLASTER	LGBT5P1	LGBT5P2	LGBT5P3	LGBT5P4	LGBT5P5	LGBT5P6
	MATTER	LGBT5M1	LGBT5M2	LGBT5M3	LGBT5M4	LGBT5M5	LGBT5M6
	CANVAS	LGBT5C1	LGBT5C2	LGBT5C3	LGBT5C4	LGBT5C5	LGBT5C6
	gradino plus* 35x45cm / 13 ³ / ₄ "x18" rett						
	PLASTER	LGGT5P1	LGGT5P2	LGGT5P3	LGGT5P4	LGGT5P5	LGGT5P6
	MATTER	LGGT5M1	LGGT5M2	LGGT5M3	LGGT5M4	LGGT5M5	LGGT5M6
	CANVAS	LGGT5C1	LGGT5C2	LGGT5C3	LGGT5C4	LGGT5C5	LGGT5C6
	angolo gradino plus* 35x35cm / 13 ³ / ₄ "x13 ³ / ₄ " rett						
	PLASTER	LG3T5P1	LG3T5P2	LG3T5P3	LG3T5P4	LG3T5P5	LG3T5P6
	MATTER	-	-	-	-	-	-
	CANVAS	LG3T5C1	LG3T5C2	LG3T5C3	LG3T5C4	LG3T5C5	LG3T5C6
	angolo sx gradino plus* 35x35cm / 13 ³ / ₄ "x13 ³ / ₄ " rett						
	PLASTER	-	-	-	-	-	-
	MATTER	LG2T5M1	LG2T5M2	LG2T5M3	LG2T5M4	LG2T5M5	LG2T5M6
	CANVAS	-	-	-	-	-	-
	angolo dx gradino plus* 35x35cm / 13 ³ / ₄ "x13 ³ / ₄ " rett						
	PLASTER	-	-	-	-	-	-
	MATTER	LG1T5M1	LG1T5M2	LG1T5M3	LG1T5M4	LG1T5M5	LG1T5M6
	CANVAS	-	-	-	-	-	-

TRAME

GRES TUTTA MASSA UGL

Full-body porcelain / Grès Cérame pleine masse
Vollgemischtes Durchgefärbtes Feinsteinzeug

SPESSORE

Thickness / Epaisseur / Stärke

11 mm



STONALIZZAZIONE

Shading / Denuançage / Spielfarbig

FUGA MINIMA CONSIGLIATA PER POSA IN INTERNO

Minimum suggested joint for indoor fixing
Joint minimum conseillé pour pose en interieure
Empfohlene Fugenbreite fuer Innenbereich
2 mm

RESISTENZA ALLO SCIVOLAMENTO

Slip resistance / Résistance au glissement
Rutschfestigkeit

DIN 51130

R9 (plaster)
R10 (matter / canvas)

RESISTENZA ALLO SCIVOLAMENTO

Slip resistance / Résistance au glissement
Rutschfestigkeit

DIN 51097

A+B (matter)

COEFFICIENTE DI ATTRITO DINAMICO B.C.R. TORTUS

$\mu > 0,40$

DYNAMIC COEFFICIENT OF FRICTION ANSI A 137.1:2012

DCOF ≥ 0.42

IMBALLI

Packing / Emballage / Verpackung

pag. 434

P R O T E C T

ANTIBATTERICO - ANTIMICROBIAL

FONDI

plain tiles / fonds / Unifliesen

		gramma 38		gramma 66 sx		gramma 66 dx		cuadra		esa		listello	
		30x90cm 12"x36"	90x90cm 36"x36"	9,7x39,2cm 3 ³ / ₄ "x15 ³ / ₈ "	16,9x39,2cm 6 ⁵ / ₈ "x15 ³ / ₈ "	16,9x39,2cm 6 ⁵ / ₈ "x15 ³ / ₈ "	11,2x9,7cm 4 ³ / ₈ "x3 ³ / ₄ "	19,5x33,8cm 7 ⁵ / ₈ "x13 ³ / ₈ "	5x45cm 2"x18"				
		rett	rett	rett	rett	rett	rett	rett	rett				
		11 mm	11 mm	11 mm	11 mm	11 mm	11 mm	11 mm	11 mm				
Lino	PLASTER	LGFT5P2	LG9T5P2	LG8T5P1	LGST5P1	LGDT5P1	LGUT5P1	LGET5P1	LGZT5P2				
	MATTER	LGFT5M2	LG9T5M2	LG8T5M1	LGST5M1	LGDT5M1	LGUT5M1	LGET5M1	LGZT5M2				
	CANVAS	LGFT5C2	LG9T5C2	LG8T5C1	LGST5C1	LGDT5C1	LGUT5C1	LGET5C1	LGZT5C2				
Corda	PLASTER	LGFT5P1	LG9T5P1	LG8T5P2	LGST5P2	LGDT5P2	LGUT5P2	LGET5P2	LGZT5P1				
	MATTER	LGFT5M1	LG9T5M1	LG8T5M2	LGST5M2	LGDT5M2	LGUT5M2	LGET5M2	LGZT5M1				
	CANVAS	LGFT5C1	LG9T5C1	LG8T5C2	LGST5C2	LGDT5C2	LGUT5C2	LGET5C2	LGZT5C1				
Tabacco	PLASTER	LGFT5P4	LG9T5P4	LG8T5P3	LGST5P3	LGDT5P3	LGUT5P3	LGET5P3	LGZT5P4				
	MATTER	LGFT5M4	LG9T5M4	LG8T5M3	LGST5M3	LGDT5M3	LGUT5M3	LGET5M3	LGZT5M4				
	CANVAS	LGFT5C4	LG9T5C4	LG8T5C3	LGST5C3	LGDT5C3	LGUT5C3	LGET5C3	LGZT5C4				
Argilla	PLASTER	LGFT5P0	LG9T5P0	LG8T5P4	LGST5P4	LGDT5P4	LGUT5P4	LGET5P4	LGZT5P0				
	MATTER	LGFT5M0	LG9T5M0	LG8T5M4	LGST5M4	LGDT5M4	LGUT5M4	LGET5M4	LGZT5M0				
	CANVAS	LGFT5C0	LG9T5C0	LG8T5C4	LGST5C4	LGDT5C4	LGUT5C4	LGET5C4	LGZT5C0				
Tortora	PLASTER	LGFT5P5	LG9T5P5	LG8T5P5	LGST5P5	LGDT5P5	LGUT5P5	LGET5P5	LGZT5P5				
	MATTER	LGFT5M5	LG9T5M5	LG8T5M5	LGST5M5	LGDT5M5	LGUT5M5	LGET5M5	LGZT5M5				
	CANVAS	LGFT5C5	LG9T5C5	LG8T5C5	LGST5C5	LGDT5C5	LGUT5C5	LGET5C5	LGZT5C5				
Moro	PLASTER	LGFT5P3	LG9T5P3	LG8T5P6	LGST5P6	LGDT5P6	LGUT5P6	LGET5P6	LGZT5P3				
	MATTER	LGFT5M3	LG9T5M3	LG8T5M6	LGST5M6	LGDT5M6	LGUT5M6	LGET5M6	LGZT5M3				
	CANVAS	LGFT5C3	LG9T5C3	LG8T5C6	LGST5C6	LGDT5C6	LGUT5C6	LGET5C6	LGZT5C3				

contemporary



BOULEVARD
60x60cm / 24"x24"
nat

30x60cm / 12"x24"
nat



DISTRICT

154 / 155

PROTECT
ANTIBATTERICO - ANTIMICROBIAL

4

FORMATI

sizes / formats / Formate



30x60cm / 12"x24" rett

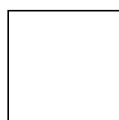

60x60cm / 24"x24" rett

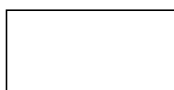

45x90cm / 18"x36" rett

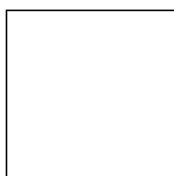

90x90cm / 36"x36" rett

2

FINITURE

finishes / surfaces / Oberfläche

NAT

GRIP

4

COLORI

colors / couleurs / Farben

Street

Avenue

Boulevard

Route

contemporary



DISTRICT



BOULEVARD
metropolitan
60x60cm / 24"x24"





AVENUE

60x60cm / 24"x24"
nat

60x60cm / 24"x24"
grip



contemporary





DISTRICT

158 / 159

ROUTE
45x90cm / 18"x36"
nat



contemporary





DISTRICT

160 / 161

ROUTE
queens mix
30x30cm / 12" x 12"



contemporary



DISTRICT

STREET

90x90cm / 36"x36"
nat



AVENUE
60x60cm / 24"x24"
grip



DISTRICT

DECORI

decors / articles / Dekore

METROPOLITAN
street
60x60cm / 24"x24"



GUGGENHEIM
street
60x60cm / 24"x24"



MOMA
street
60x60cm / 24"x24"



METROPOLITAN
avenue
60x60cm / 24"x24"



GUGGENHEIM
avenue
60x60cm / 24"x24"



MOMA
avenue
60x60cm / 24"x24"



CENTRAL PARK
street
30x30cm / 12"x12"

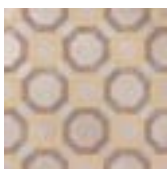

BRYANT PARK
street
30x30cm / 12"x12"

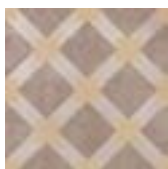

QUEENS MIX
street
30x30cm / 12"x12"

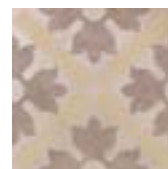

CENTRAL PARK
avenue
30x30cm / 12"x12"

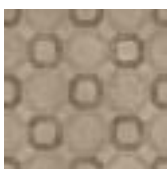

BRYANT PARK
avenue
30x30cm / 12"x12"

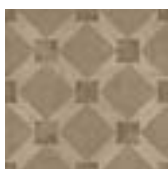

QUEENS MIX
avenue
30x30cm / 12"x12"

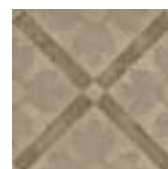

METROPOLITAN
boulevard
60x60cm / 24"x24"



GUGGENHEIM
boulevard
60x60cm / 24"x24"



MOMA
boulevard
60x60cm / 24"x24"



METROPOLITAN
route
60x60cm / 24"x24"



GUGGENHEIM
route
60x60cm / 24"x24"



MOMA
route
60x60cm / 24"x24"



CENTRAL PARK
boulevard
30x30cm / 12"x12"



BRYANT PARK
boulevard
30x30cm / 12"x12"



QUEENS MIX
boulevard
30x30cm / 12"x12"



CENTRAL PARK
route
30x30cm / 12"x12"



BRYANT PARK
route
30x30cm / 12"x12"

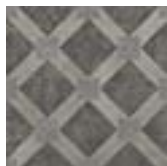

QUEENS MIX
route
30x30cm / 12"x12"

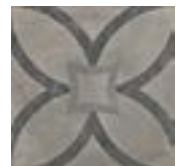
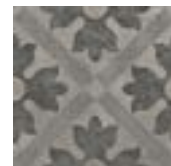
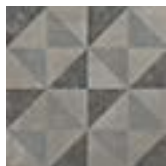

DISTRICT

MOSAICI

mosaics / mosaïques / Mosaik

MURETTO
street
30x60cm / 12"x24"



MOSAICO 81
street
30x30cm / 12"x12"

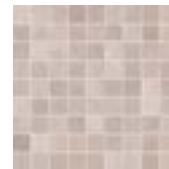

MOSAICO MATTONE
street
30x30cm / 12"x12"



MURETTO
avenue
30x60cm / 12"x24"



MOSAICO 81
avenue
30x30cm / 12"x12"

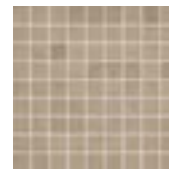

MOSAICO MATTONE
avenue
30x30cm / 12"x12"



MURETTO
boulevard
30x60cm / 12"x24"



MOSAICO 81
boulevard
30x30cm / 12"x12"

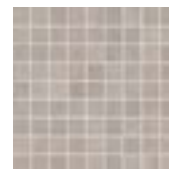

MOSAICO MATTONE
boulevard
30x30cm / 12"x12"

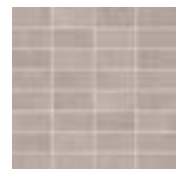

MURETTO
route
30x60cm / 12"x24"



MOSAICO 81
route
30x30cm / 12"x12"

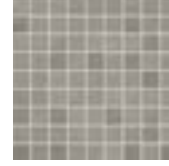

MOSAICO MATTONE
route
30x30cm / 12"x12"





PEZZI SPECIALI

trims / pièces spéciales / Formstücke

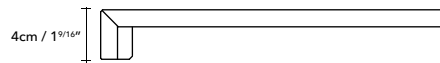
Sezione gradino



		Street	Avenue	Boulevard	Route
 battiscopa 10x60,4cm / 4"x24" rett	NAT	LGBDS30	LGBDS00	LGBDS10	LGBDS20
	GRIP	-	-	-	-
 gradino plus* 35x120cm / 13 ^{3/4} "x48" rett	NAT	LG9DSG3	LG9DSG0	LG9DSG1	LG9DSG2
	GRIP	LG9DSG8	LG9DSG5	LG9DSG6	LG9DSG7
 angolo dx / sx gradino plus* 35x120cm / 13 ^{3/4} "x48" rett	NAT	LG9DSA3	LG9DSA0	LG9DSA1	LG9DSA2
	GRIP	LG9DSA8	LG9DSA5	LG9DSA6	LG9DSA7

* Su richiesta. Per maggiori informazioni circa quantità minime e tempi di consegna rivolgersi all'ufficio commerciale. / Upon request. For more information about minimum quantities and delivery times please contact the sales department. / Sur demande. Pour plus d'informations sur les quantités minimales et délais de livraison s'il vous plaît contacter le département des ventes. / auf Anfrage. Für weitere Infos über die Mindestmengen und Lieferzeiten wenden Sie sich bitte an unserer Verkaufsabteilung.



DECORI E MOSAICI

decors and mosaics / décors et mosaïques / Dekore und Mosaike

	METROPOLITAN	GUGGENHEIM	MOMA	CENTRAL PARK	BRYANT PARK	QUEENS MIX	MURETTO	MOSAICO 81	MOSAICO MATTONE
	60×60cm 24"×24"	60×60cm 24"×24"	60×60cm 24"×24"	30×30cm 12"×12"	30×30cm 12"×12"	30×30cm 12"×12"	30×60cm 12"×24"	30×30cm 12"×12"	30×30cm 12"×12"
Street	 LGWDST3	LGWDSH3	LGWDSM3	LGPDSC3	LGPDS30	LGPDSQ3	LGVDS83	LG9DS83	LG9DS93
Avenue	 LGWDST0	LGWDSH0	LGWDSM0	LGPDSC0	LGPDS00	LGPDSQ0	LGVDS80	LG9DS80	LG9DS90
Boulevard	 LGWDST1	LGWDSH1	LGWDSM1	LGPDSC1	LGPDS10	LGPDSQ1	LGVDS81	LG9DS81	LG9DS91
Route	 LGWDST2	LGWDSH2	LGWDSM2	LGPDSC2	LGPDS20	LGPDSQ2	LGVDS82	LG9DS82	LG9DS92

DISTRICT

168/169

STREET

moma
60x60cm / 24"x24"

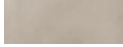

DISTRICT

GRES TUTTA MASSA UGL

Full-body porcelain / Grès Cérame pleine masse
Vollgemischtes Durchgefärbtes Feinsteinzeug

SPESSORE

Thickness / Epaisseur / Stärke

10 mm (30x60 - 60x60)

11 mm (45x90 - 90x90)



STONALIZZAZIONE

Shading / Denuançage / Spielfarbig

COEFFICIENTE DI ATTRITO DINAMICO B.C.R. TORTUS

$\mu > 0,40$

FUGA MINIMA CONSIGLIATA PER POSA IN INTERNO

Minimum suggested joint for indoor fixing
Joint minimum conseillé pour pose en enterieure
Empfohlene Fugenbreite fuer Innenbereich

2 mm

RESISTENZA ALLO SCIVOLAMENTO

Slip resistance / Résistance au glissement
Rutschfestigkeit

DIN 51130

R10 (nat.)

R11 (grip)

RESISTENZA ALLO SCIVOLAMENTO

Slip resistance / Résistance au glissement
Rutschfestigkeit

DIN 51097

A+B (nat.) / A+B+C (grip)

DYNAMIC COEFFICIENT OF FRICTION ANSI A 137.1:2012

DCOF \geq 0.42

WET PENDULUM TEST

AS 4586:2013

Class P4 (grip)

BRITISH PENDULUM TEST - BS 7976:2002

4S (SLIDER 96)

Dry: low slip potential PTV 36+ (grip)

Wet: low slip potential PTV 36+ (grip)

TRL (SLIDER 55)

Dry: low slip potential PTV 36+ (grip)

Wet: low slip potential PTV 36+ (grip)

IMBALLI

Packing / Emballage / Verpackung

pag. 427

P R () T E C T

ANTIBATTERICO - ANTIMICROBIAL

FONDI

plain tiles / fonds / Unifliesen

			30x60cm 12"x24"	60x60cm 24"x24"	45x90cm 18"x36"	90x90cm 36"x36"
			rett	rett	rett	rett
			10 mm	10 mm	11 mm	11 mm
Street		NAT	LGVDS30	LGWDS30	LGGDS30	LG9DS30
		GRIP	-	LGWDS35	-	-
Avenue		NAT	LGVDS00	LGWDS00	LGGDS00	LG9DS00
		GRIP	-	LGWDS05	-	-
Boulevard		NAT	LGVDS10	LGWDS10	LGGDS10	LG9DS10
		GRIP	-	LGWDS15	-	-
Route		NAT	LGVDS20	LGWDS20	LGGDS20	LG9DS20
		GRIP	-	LGWDS25	-	-

contemporary



RIO COFFEE

60x60cm / 24"x24"
nat



MILANO ECRU

60x60cm / 24"x24"
nat



bacchetta metal moka
1,5x60cm / 5/8"x24"



METROPOLIS

170/
171

P R () T E C T
ANTIBATTERICO - ANTIMICROBIAL

4

FORMATI

sizes / formats / Formate

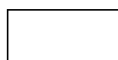

30x60 cm / 12"x24" rett



60x60cm/24"x24" rett



45x90cm/18"x36" rett

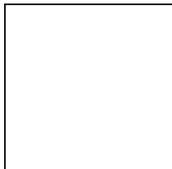

90x90cm/36"x36" rett

3

FINITURE

finishes / surfaces / Oberfläche

NAT

TEXT

TEXT GRIP

8

COLORI

colors / couleurs / Farben

Tokyo White

London Gray

Paris Amande

Shanghai Iron

Milano Ecrú

Berlin Night

New York Coal

Rio Coffee



METROPOLIS

NEW YORK COAL

60x60cm / 24"x24"

nat



172/
173

SHANGHAI IRON

30x60cm / 12"x24"

nat



muretto urban cold
30x60cm / 12"x24"

bacchetta metal titanio
1,5x60cm / 5/8"x24"

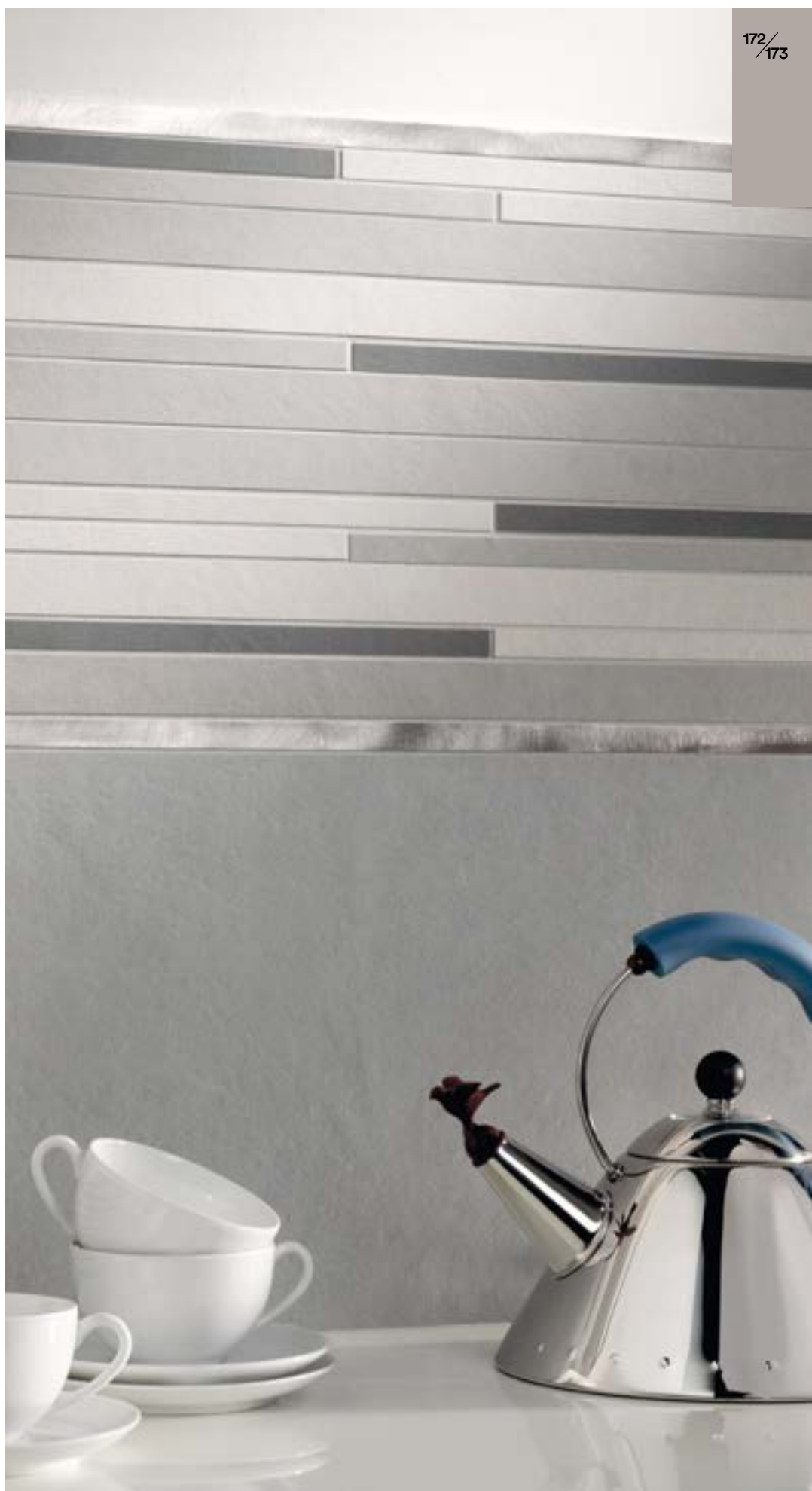

contemporary

METROPOLIS



TOKYO WHITE
60x60cm / 24"x24"
texture grip

30x60cm / 12"x24"
texture grip





contemporary

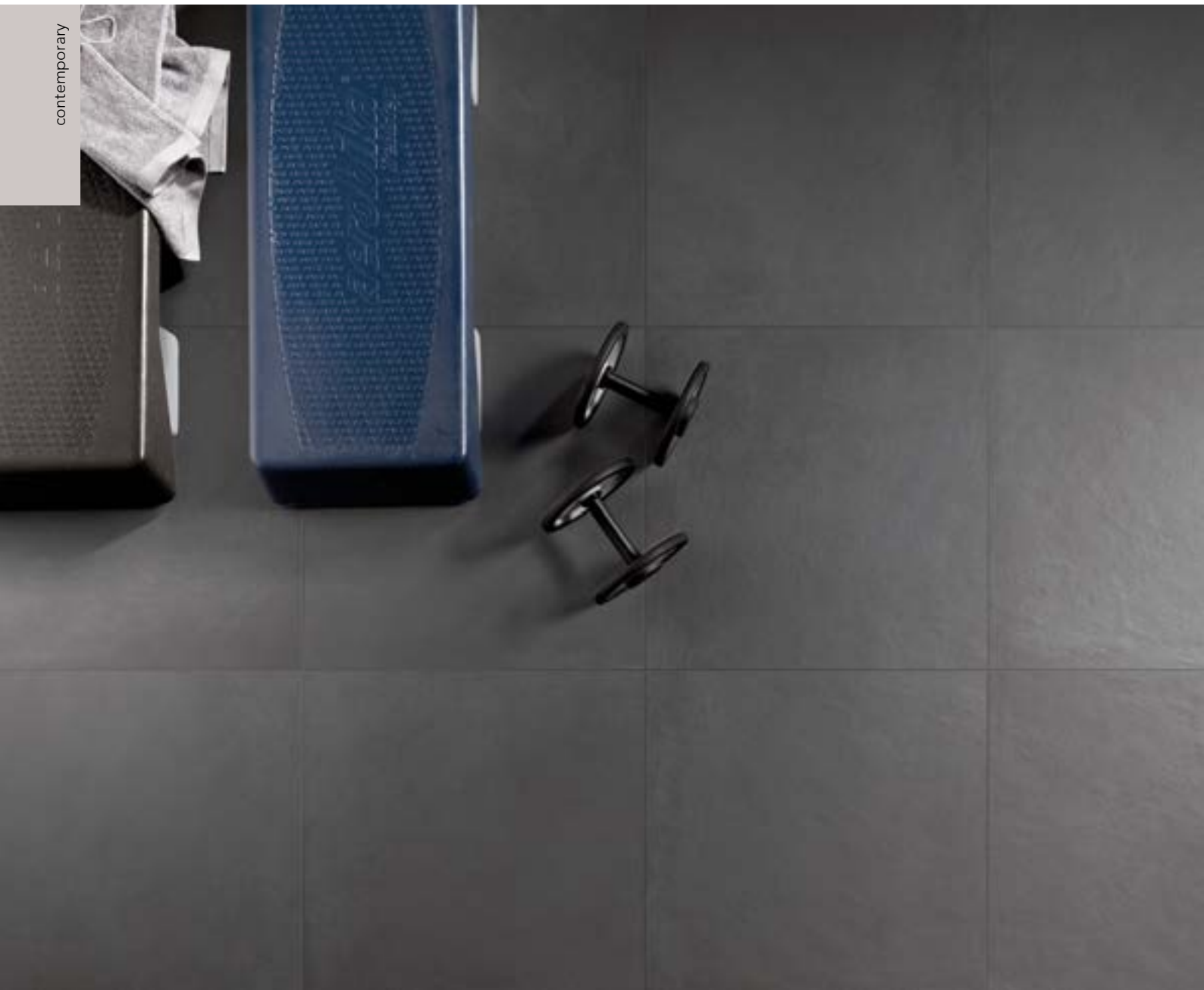

METROPOLIS

BERLIN NIGHT
60x60cm / 24"x24"
nat





LONDON GRAY
60x60cm / 24"x24"
nat



METROPOLIS

DECORI E MOSAICI

decors and mosaics / décors et mosaïques / Dekore und Mosaïke

MURETTO AVENUE 3D
30x60cm / 12"x24"
tokyo white



MURETTO URBAN
30x60cm / 12"x24"
cold

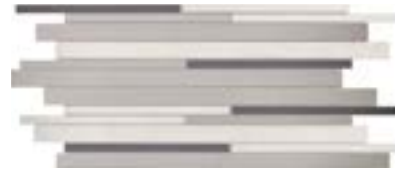

MURETTO AVENUE 3D
30x60cm / 12"x24"
milano ecru



MURETTO URBAN
30x60cm / 12"x24"
warm



MURETTO AVENUE 3D
30x60cm / 12"x24"
shanghai iron



BACCHETTA METAL
1,5x60cm / 5/8"x24"
titanio



BACCHETTA METAL
1,5x60cm / 5/8"x24"
nero



MURETTO AVENUE 3D
30x60cm / 12"x24"
rio coffee



BACCHETTA METAL
1,5x60cm / 5/8"x24"
moka



MURETTO AVENUE 3D
30x60cm / 12"x24"
berlin night







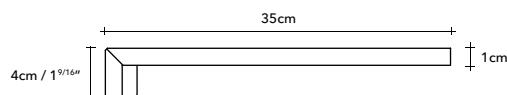

PEZZI SPECIALI

trims / pièces spéciales / Formstücke

Sezione gradino



	Tokyo White	Paris Amande	Milano Ecreu	Rio Coffee	London Gray	Shanghai Iron	New York Coal	Berlin Night
 battiscopa nat. 10x60cm / 4"x24" rett	LGBMLN1	LGBMLN3	LGBMLN2	LGBMLN0	LGBMLN6	LGBMLN5	LGBMLN4	LGBMLN7
 gradino plus nat.* 35x60cm / 13 ^{3/4} "x24" rett	LG9MLG1	LG9MLG3	LG9MLG2	LG9MLG0	LG9MLG6	LG9MLG5	LG9MLG4	LG9MLG7
 angolo sx / dx gradino plus nat.* 35x35cm / 13 ^{3/4} "x13 ^{3/4} " rett	LG9MLA1	LG9MLA3	LG9MLA2	LG9MLA0	LG9MLA6	LG9MLA5	LG9MLA4	LG9MLA7
 battiscopa texture grip 10x60cm / 4"x24" rett	LGBMLT1	-	LGBMLT2	LGBMLT0	-	LGBMLT5	-	-
 gradino plus texture grip* 35x60cm / 13 ^{3/4} "x24" rett	LG9MLY1	-	LG9MLY2	LG9MLY0	-	LG9MLY5	-	-
 angolo sx / dx gradino plus texture grip* 35x35cm / 13 ^{3/4} "x13 ^{3/4} " rett	LG9MLX1	-	LG9MLX2	LG9MLX0	-	LG9MLX5	-	-

* Su richiesta. Per maggiori informazioni circa quantità minime e tempi di consegna rivolgersi all'ufficio commerciale. / Upon request. For more information about minimum quantities and delivery times please contact the sales department. / Sur demande. Pour plus d'informations sur les quantités minimales et délais de livraison s'il vous plaît contacter le département des ventes. / auf Anfrage. Für weitere Infos über die Mindestmengen und Lieferzeiten wenden Sie sich bitte an unserer Verkaufsabteilung.

METROPOLIS

METROPOLIS

GRES TUTTA MASSA UGL

Full-body porcelain / Grès Cérame pleine masse /
Vollgemischtes Durchgefärbtes Feinsteinzeug /

SPESORE

Thickness / Epaisseur / Stärke

10 mm (30x60 - 60x60)

11 mm (75x75 - 45x90 - 90x90)



STONALIZZAZIONE

Shading / Denuançage / Spielfarbig

COEFFICIENTE DI ATTRITO DINAMICO

B.C.R. TORTUS







$\mu > 0,40$

FUGA MINIMA CONSIGLIATA PER POSA IN INTERNO

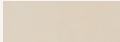
Minimum suggested joint for indoor fixing
Joint minimum conseillé pour pose en interieure
Empfohlene Fugenbreite fuer Innenbereich
2 mm

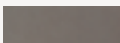
DECORI E MOSAICI

decors and mosaics / décors et mosaïques / Dekore und Mosaïke

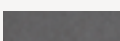
	MURETTO AVENUE 3D		MURETTO URBAN COLD		MURETTO URBAN WARM			
	30x60cm 12"x24"		30x60cm 12"x24"		30x60cm 12"x24"			
Tokyo White		LG9MLM1	LG9MLC0		LG9MLW0			
Paris Amande		-						
Milano Ecreu		LG9MLM2						
Rio Coffee		LG9MLM0						
London Gray		-						
Shanghai Iron		LG9MLM5						
New York Coal		-						
Berlin Night		LG9MLM7						
			BACCHETTA METAL TITANIO		BACCHETTA METAL NERO		BACCHETTA METAL MOKA	
			1,5x60cm 5/8"x24"		1,5x60cm 5/8"x24"		1,5x60cm 5/8"x24"	
			LG9ML0T		LG9ML0N		LG9ML0G	

RESISTENZA ALLO SCIVOLAMENTOSlip resistance / Résistance au glissement
Rutschfestigkeit**DIN 51130**

R10 (naturale/spazzolato/texture)

R11 (texture grip)

RESISTENZA ALLO SCIVOLAMENTOSlip resistance / Résistance au glissement
Rutschfestigkeit**DIN 51097**

A+B+C (texture grip)

DYNAMIC COEFFICIENT OF FRICTION**ANSI A 137.1:2012**DCOF \geq 0.42**WET PENDULUM TEST****AS 4586:2004**

Class P3 (texture grip)

BRITISH PENDULUM TEST - BS 7976:2002**4S (SLIDER 96)**Dry: low slip potential PTV 36+
(naturale/texture grip)

Wet: low slip potential PTV 36+ (naturale)

Low slip potential PTV 36+ (texture grip)

TRL (SLIDER 55)

Dry: low slip potential PTV 36+ (texture grip)

Wet: low slip potential PTV 36+ (texture grip)

IMBALLI

Packing / Emballage / Verpackung





pag. 430

P R () T E C T

ANTIBATTERICO - ANTIMICROBIAL

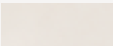
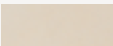
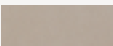
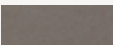
FONDI

plain tiles / fonds / Unifliesen

			30x60cm	60x60cm	45x90cm	90x90cm
			12"x24"	24"x24"	18"x36"	36"x36"
			rett	rett	rett	rett
			10 mm	10 mm	11 mm	11 mm
Tokyo White		NAT	LGVML10	LGWML1R	-	-
		TEXT	-	-	LGGML10	LG9ML10
		TEXT GRIP	LGVML16	LGWML16	-	-
Paris Amande		NAT	LGVML30	LGWML3R	-	-
		TEXT	-	-	LGGML30	LG9ML30
		TEXT GRIP	-	-	-	-
Milano Ecrú		NAT	LGVML20	LGWML2R	-	-
		TEXT	-	-	LGGML20	LG9ML20
		TEXT GRIP	LGVML26	LGWML26	-	-
Rio Coffee		NAT	LGVML00	LGWML0R	-	-
		TEXT	-	-	LGGML00	LG9ML00
		TEXT GRIP	LGVML06	LGWML06	-	-
London Gray		NAT	LGVML60	LGWML6R	-	-
		TEXT	-	-	LGGML60	LG9ML60
		TEXT GRIP	-	-	-	-
Shanghai Iron		NAT	LGVML50	LGWML5R	-	-
		TEXT	-	-	LGGML50	LG9ML50
		TEXT GRIP	LGVML56	LGWML56	-	-
New York Coal		NAT	LGVML40	LGWML4R	-	-
		TEXT	-	-	LGGML40	LG9ML40
		TEXT GRIP	-	-	-	-
Berlin Night		NAT	LGVML70	LGWML7R	-	-
		TEXT	-	-	LGGML70	LG9ML70
		TEXT GRIP	-	-	-	-

contemporary

PAPIRO BIANCO

2x60cm / 3/4"x24"

9,7x60cm / 3³/₄"x24"

60x60cm / 24"x24"



wallpaper grey
20x60cm / 8"x24"



5

FORMATI

sizes / formats / Formate



2x2cm / 3/4"x3/4" rett

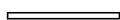

2x60cm / 3/4"x24" rett

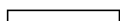
9,7x60cm / 3³/₄"x24" rett

30x60 cm / 12"x24" rett



60x60cm / 24"x24" rett

5

COLORI

colors / couleurs / Farben

Papiro Bianco

Yucca Grigio

Linen Beige

Java Scuro

Cedar Bruno



MAKÒ

YUCCA GRIGIO
30x60cm / 12"x24"

60x60cm / 24"x24"



decoro pin striped
30x60cm / 12"x24"

decoro corset
30x30cm / 12"x12"

fascia twill cold
3x60cm / 1³/₁₆"x24"

CEDAR BRUNO
30x60cm / 12"x24"

decoro tartan
30x60cm / 12"x24"



PAPIRO BIANCO
60x60cm / 24"x24"





DECORI

decors / articles / Dekore

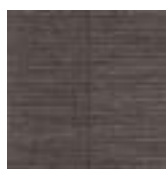
DECORO PIN STRIPEDpapiro bianco
30x60cm / 12"x24"**DECORO CORSET**papiro bianco
30x30cm / 12"x12"**DECORO PIN STRIPED**linen beige
30x60cm / 12"x24"**DECORO CORSET**linen beige
30x30cm / 12"x12"**DECORO CROSS**linen beige
30x60cm / 12"x24"**DECORO PIN STRIPED**yucca grigio
30x60cm / 12"x24"**DECORO CORSET**yucca grigio
30x30cm / 12"x12"**DECORO CROSS**yucca grigio
30x60cm / 12"x24"**DECORO PIN STRIPED**cedar bruno
30x60cm / 12"x24"**DECORO CORSET**cedar bruno
30x30cm / 12"x12"**DECORO TARTAN**cedar bruno
30x60cm / 12"x24"**DECORO PIN STRIPED**java scuro
30x60cm / 12"x24"**DECORO CORSET**java scuro
30x30cm / 12"x12"**DECORO TARTAN**java scuro
30x60cm / 12"x24"

DECORO WALLPAPER

grey
20x60cm / 8"x24"

DECORO WALLPAPER

beige
20x60cm / 8"x24"

FASCIA TWILL

cold
3x60cm / 1³/₁₆"x24"

FASCIA TWILL

warm
3x60cm / 1³/₁₆"x24"

FASCIA BROCADE

cold
3x60cm / 1³/₁₆"x24"

FASCIA BROCADE

warm
3x60cm / 1³/₁₆"x24"

DECORO WALLFLOWER

cedar bruno
papiro bianco
linen beige
yucca grigio
java scuro
30x60cm / 12"x24"

contemporary

MAKÒ

PAPIRO BIANCO
60x60cm / 24"x24"



beige decoro cross
30x60cm / 12"x24"



PEZZI SPECIALI

trims / pièces spéciales / Formstücke

	Papiro Bianco 	Linen Beige 	Cedar Bruno 	Yucca Grigio 	Java Scuro 
 battiscopa 10x60cm / 4"x24" rett	LGBMK00	LGBMK10	LGBMK30	LGBMK20	LGBMK40
 gradino step 60x60cm / 24"x24" rett	LGCMKR0	LGCMKR1	LGCMKR3	LGCMKR2	LGCMKR4
 raccordo jolly 1,3x30cm / 1/2"x12" rett	LG9MK42	LG9MK43	LG9MK45	LG9MK44	LG9MK46
 beak jolly 1,3x1,3cm / 1/2"x1/2" rett	LG9MK47	LG9MK48	LG9MK50	LG9MK49	LG9MK51

MAKÒ

wallpaper grey
20x60cm / 8"x24"



DECORI

decors / articles / Dekore

		PIN STRIPED	CORSET	CROSS	TARTAN	WALLFLOWER
		30x60cm 12"x24"	30x30cm 12"x12"	30x60cm 12"x24"	30x60cm 12"x24"	30x60cm 12"x24"
Papiro Bianco		LG9MK23	LG9MK16	-	-	LG9MK05
Linen Beige		LG9MK24	LG9MK17	LG9MK10	-	LG9MK06
Cedar Bruno		LG9MK27	LG9MK20	-	LG9MK13	LG9MK09
Yucca Grigio		LG9MK25	LG9MK18	LG9MK11	-	LG9MK07
Java Scuro		LG9MK26	LG9MK19	-	LG9MK12	LG9MK08
WALLPAPER GREY	WALLPAPER BEIGE	FASCIA TWILL COLD	FASCIA TWILL WARM	FASCIA BROCADE COLD	FASCIA BROCADE WARM	
20x60cm 8"x24"	20x60cm 8"x24"	3x60cm 1 ³ / ₁₆ "x24"	3x60cm 1 ³ / ₁₆ "x24"	3x60cm 1 ³ / ₁₆ "x24"	3x60cm 1 ³ / ₁₆ "x24"	
LG9MK14	LG9MK15	LG9MK41	LG9MK40	LG9MK22	LG9MK21	

MAKÒ

GRES SMALTATO A MASSA COLORATA GL

Colored-body glazed porcelain / Grès émaillé a masse colorée / Glasiertes Feinsteinzeug mit farbiger masse

SPESSORE

Thickness / Epaisseur / Stärke

11 mm



STONALIZZAZIONE

Shading / Denuançage / Spielfarbig

COEFFICIENTE DI ATTRITO DINAMICO B.C.R. TORTUS

$\mu > 0,40$

FUGA MINIMA CONSIGLIATA PER POSA IN INTERNO

Minimum suggested joint for indoor fixing
Joint minimum conseillé pour pose en entérieure
Empfohlene Fugenbreite fuer Innenbereich

2 mm

RESISTENZA ALLO SCIVOLAMENTO

Slip resistance / Résistance au glissement
Rutschfestigkeit

DIN 51130

R9

RESISTENZA ALL'ABRASIONE SUPERFICIALE

Resistance to superficial abrasion
Résistance à l'abrasion superficielle
Oberflächliche reibungsbeständigkeit

ISO 10545-7

pei 5 (papiro bianco/linen beige/yucca grigio)

pei 4 (cedar bruno/java scuro)

IMBALLI

Packing / Emballage / Verpackung

pag. 429

FONDI

plain tiles / fonds / Unifliesen

		2x2cm 3/4"x3/4"	2x60cm 3/4"x24"	9,7x60cm 3 3/4"x24"	30x60cm 12"x24"	60x60cm 24"x24"
		rett	rett	rett	rett	rett
		11 mm	11 mm	11 mm	11 mm	11 mm
Papiro Bianco		LG9MK35	LG9MK30	LG9MK00	LGVMKR0	LGWMKR0
Linen Beige		LG9MK36	LG9MK31	LG9MK01	LGVMKR1	LGWMKR1
Cedar Bruno		LG9MK38	LG9MK33	LG9MK03	LGVMKR3	LGWMKR3
Yucca Grigio		LG9MK37	LG9MK32	LG9MK02	LGVMKR2	LGWMKR2
Java Scuro		LG9MK39	LG9MK34	LG9MK04	LGVMKR4	LGWMKR4

contemporary



SILT
60x60 cm / 24"x24"



STONECLAY

home
by LEA CERAMICHE

4

FORMATI

sizes / formats / Formate



45,2x45,2cm / 18"x18" nat



30x60 cm / 12"x24" rett

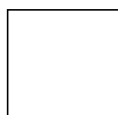

60x60cm / 24"x24" rett

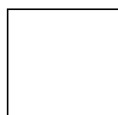

60,4x60,4cm / 24"x24" nat

SYSTEM L2



60x60cm / 24"x24" rett
± 20mm

4

COLORI

colors / couleurs / Farben

Silt

Lime

Charcoal

Cendre

contemporary

STONECLAY



LIME
30x60cm / 12"x24"



LEA CERAMICHE



contemporary

STONECLAY

CENDRE

60x60cm / 24"x24"



MOSAICI

mosaics / mosaïques / Mosaik

MOSAICO
silt
30x30cm / 12"x12"

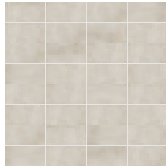

MOSAICO
lime
30x30cm / 12"x12"



MOSAICO
cendre
30x30cm / 12"x12"

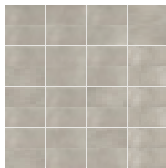

MOSAICO
charcoal
30x30cm / 12"x12"

**PEZZI SPECIALI**

trims / pièces spéciales / Formstücke



battiscopa
10x60cm / 4"x24" rett

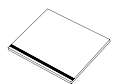

gradino step
60x60cm / 24"x24" rett

	SILT	LIME	CENDRE	CHARCOAL
				
	LGBSY30	LGBSY10	LGBSY20	LGBSY00
	LGCSY30	LGCSY10	LGCSY20	LGCSY00

STONECLAY

CHARCOAL

60x60cm / 24"x24"



MOSAICI

mosaics / mosaiques / Mosaik

MOSAICO

30x30cm
12"x12"

Silt		LG9SYM3
Lime		LG9SYM1
Cendre		LG9SYM2
Charcoal		LG9SYM0

STONECLAY

GRES TUTTA MASSA UGL

Full-body porcelain / Grès Cérame pleine masse / Vollgemischtes Durchgefärbtes Feinsteinzeug

SPESSORE

Thickness / Epaisseur / Stärke

9 mm (45,2x45,2)

10 mm (30x60 - 60x60 - 60,4x60,4)



STONALIZZAZIONE

Shading / Denuançage / Spielfarbig

COEFFICIENTE DI ATTRITO DINAMICO B.C.R. TORTUS

$\mu > 0,40$

FUGA MINIMA CONSIGLIATA PER POSA IN INTERNO

Minimum suggested joint for indoor fixing
Joint minimum conseillé pour pose en entérieure
Empfohlene Fugenbreite fuer Innenbereich
2 mm rett. / 4 mm nat.

RESISTENZA ALLO SCIVOLAMENTO

Slip resistance / Résistance au glissement
Rutschfestigkeit

DIN 51130

R10

RESISTENZA ALLO SCIVOLAMENTO

Slip resistance / Résistance au glissement
Rutschfestigkeit

DIN 51097

A+B

DYNAMIC COEFFICIENT OF FRICTION

ANSI A 137.1:2012

DCOF \geq 0.42

WET PENDULUM TEST

AS 4586:2013

Class P3

BRITISH PENDULUM TEST - BS 7976:2002

4S (SLIDER 96)

Dry: low slip potential PTV 36+

Wet: low slip potential PTV 36+





IMBALLI

Packing / Emballage / Verpackung

pag. 432

FONDI

plain tiles / fonds / Unifliesen

		45,2x45,2cm 18"x18"	30x60cm 12"x24"	60x60cm 24"x24"	60,4x60,4cm 24"x24"	60x60cm 24"x24"
		nat	rett	rett	nat	rett
		9 mm	10 mm	10 mm	10 mm	20 mm - SYSTEM L2
Silt		LGTSY30	-	-	LGWSY30	-
		-	LGVSyr3	LGWSYR3	-	-
Lime		LGTSY10	-	-	LGWSY10	-
		-	LGVSyr1	LGWSYR1	-	LGWK201
Cendre		LGTSY20	-	-	LGWSY20	-
		-	LGVSyr2	LGWSYR2	-	LGWK211
Charcoal		LGTSY00	-	-	LGWSY00	-
		-	LGVSyr0	LGWSYR0	-	-

contemporary

GREY
60,4x60,4cm / 24"x24"



BLOCK

200/
201

home
by LEA
CERAMICHE

2

FORMATI

sizes / formats / Formate



60x60cm / 24"x24" rett

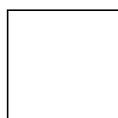

60,4x60,4cm / 24"x24" nat

5

COLORI

colors / couleurs / Farben

Ice

Grey

Sand

Dark

Nut

contemporary





BLOCK

ICE
60x60cm / 24"x24"



202/
203

BLOCK

MOSAICI

mosaics / mosaïques / Mosaik

MOSAICO 36
ice
30x30cm / 12"x12"

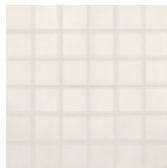

FASCIA
chiara
10x60,4cm / 4"x24"



MOSAICO 36
sand
30x30cm / 12"x12"

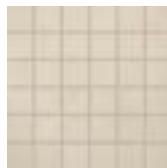

MOSAICO 36
nut
30x30cm / 12"x12"

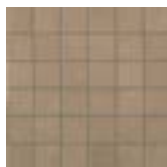

MOSAICO 36
grey
30x30cm / 12"x12"

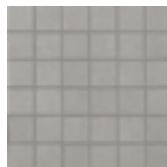

FASCIA
scura
10x60,4cm / 4"x24"



MOSAICO 36
dark
30x30cm / 12"x12"



PEZZI SPECIALI

trims / pièces spéciales / Formstücke



battiscopa
10x60,4cm / 4"x24" nat

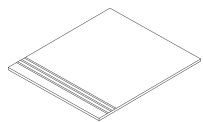

gradino step
60,4x60,4cm / 24"x24" nat

	Ice	Sand	Nut	Grey	Dark
					
	LGBBK00	LGBBK10	LGBBK30	LGBBK20	LGBBK50
	LGCBK00	LGCBK10	LGCBK30	LGCBK20	LGCBK50

BLOCK

GREY

60x60cm / 24"x24"



MOSAICI

mosaics / mosaïques / Mosaik

		MOSAICO 36
		30x30cm 12"x12"
Ice		LG9BKM0
Sand		LG9BKM1
Nut		LG9BKM3
Grey		LG9BKM2
Dark		LG9BKM5

FASCIA CHIARA	FASCIA SCURA
10x60,4cm 4"x24"	10x60,4cm 4"x24"
LG9BK00	LG9BK01

BLOCK

GRES SMALTATO GL

Glazed porcelain / Grès émailé
Glesiertes Feinsteinzeug

SPESORE

Thickness / Epaisseur / Stärke

10 mm



STONALIZZAZIONE

Shading / Denuançage / Spielfarbig

FUGA MINIMA CONSIGLIATA PER POSA IN INTERNO

Minimum suggested joint for indoor fixing
Joint minimum conseillé pour pose en enterieure
Empfohlene Fugenbreite fuer Innenbereich

2 mm rett. / 4 mm nat.

RESISTENZA ALL'ABRASIONE SUPERFICIALE ISO 10545-7

Resistance to superficial abrasion
Résistance à l'abrasion superficielle
Oberflächliche reibungsbeständigkeit

pei 4 (ice/sand/grey/nut)

pei 3 (dark)





IMBALLI

Packing / Emballage / Verpackung

pag. 427

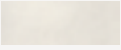
FONDI

plain tiles / fonds / Unifliesen

		60x60cm* 24"x24"	60,4x60,4cm 24"x24"
		rett 10 mm	nat 10 mm
Ice		LGWBK0R	LGWBK00
Sand		LGWBK1R	LGWBK10
Nut		LGWBK3R	LGWBK30
Grey		LGWBK2R	LGWBK20
Dark		LGWBK5R	LGWBK50

* Su richiesta / Upon request / Sur demande / Auf Anfrage

stone



SILVER FLOW

60x60cm / 24"x24"
lapp



GRAY FLOW

brick
30x30cm / 12"x12"
lapp



WATERFALL

208/
209

P R () E C T
ANTIBATTERICO - ANTIMICROBIAL

10

FORMATI

sizes / formats / Formate

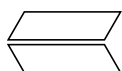

gramma 72
49,8x16,9cm / 19^{1/2}"x6^{5/8}" rett



30x60cm / 12"x24" rett

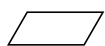

gramma 66 dx
39,2x19,5cm / 15^{3/8}"x7^{5/8}" rett



60x60cm / 24"x24" rett

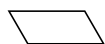

gramma 66 sx
39,2x19,5cm / 15^{3/8}"x7^{5/8}" rett

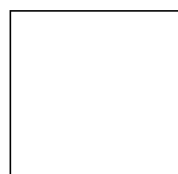

90x90cm / 36"x36" rett



gramma 16 sx
19,5x9,7cm / 7^{5/8}"x3^{3/4}" rett



45x90cm / 18"x36" rett



gramma 16 dx
19,5x9,7cm / 7^{5/8}"x3^{3/4}" rett



60x120cm / 24"x48" rett

SYSTEM L2



45x90cm / 18"x36"
± 20mm

3

FINITURE

finishes / surfaces / Oberfläche

NAT

LAPP

GRIP

4

COLORI

colors / couleurs / Farben

Ivory flow

Silver flow

Gray flow

Dark flow

stone



WATERFALL

CHEVRON

GRAY FLOW
gramma 72
nat





IVORY FLOW
90x90cm / 36"x36"
nat



stone





WATERFALL

DARK FLOW
mosaico 36
30x30cm / 12"x12"
lapp



DARK FLOW
60x60cm / 24"x24"
lapp



stone



WATERFALL

ARROW

SILVER FLOW

gramma 16 dx e sx
nat

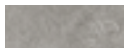

DARK FLOW

gramma 16 dx e sx
nat



IVORY FLOW
muretto 3D
30x60cm / 12"x24"
lapp



214/
215

WATERFALL

MOSAICI

mosaics / mosaïques / Mosaik

MURETTO
30x60 cm / 12"x24" rett

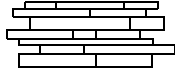

BRICK
30x60 cm / 12"x24" rett

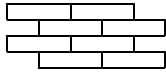

MURETTO 3D
30x60 cm / 12"x24" rett

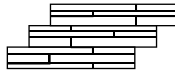

MOSAICO 36
30x30 cm / 12"x12" rett



FORMATI SPECIALI

special sizes / formats spéciaux /
Sonderformate

GRAMMA 72
49,8x16,9cm / 19¹/₂"x6⁵/₈" rett



GRAMMA 66 DX
39,2x19,5cm / 15³/₈"x7⁵/₈" rett



GRAMMA 66 SX
39,2x19,5cm / 15³/₈"x7⁵/₈" rett

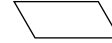

GRAMMA 16 DX
19,5x9,7cm / 7⁵/₈"x3³/₄" rett



GRAMMA 16 SX
19,5x9,7cm / 7⁵/₈"x3³/₄" rett



COMPOSIZIONI A MODULI SFUSI

tile layouts in loose modules / compositions en modules en vrac / Kompositionen mit Einzelmodulen

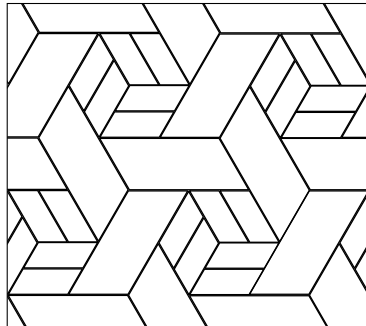

BASKET Gramma 66 sx + Gramma 16 dx

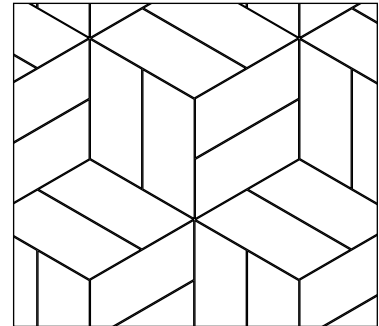

TWIST Gramma 66 dx o Gramma 16 dx

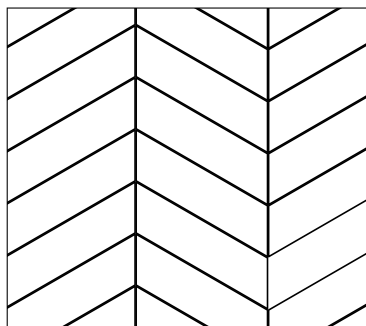

CHEVRON Gramma 72

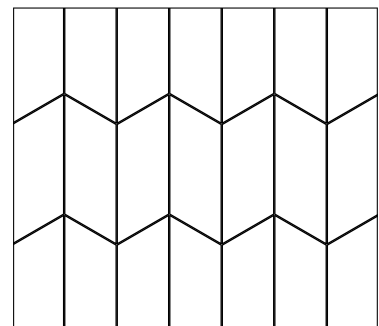





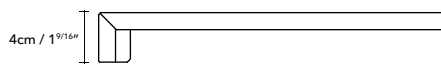

ARROW Gramma 66 dx e sx o
Gramma 16 dx e sx

PEZZI SPECIALI

trims / pièces spéciales / Formstücke

Sezione gradino



		Ivory flow	Silver flow	Gray flow	Dark flow
 battiscopa 10x60cm / 4"x24" rett	LAPP	LGBWFL2	LGBWFL3	LGBWFL1	LGBWFL0
	NAT	LGBWFN2	LGBWFN3	LGBWFN1	LGBWFN0
 gradino plus* 35x120cm / 13 ^{3/4} "x48" rett	LAPP	LG8WF70	LG8WF80	LG8WF60	LG8WF50
	NAT	LG8WF20	LG8WF30	LG8WF10	LG8WF00
 angolo dx gradino plus* 35x120cm / 13 ^{3/4} "x48" rett	LAPP	LG8WF71	LG8WF81	LG8WF61	LG8WF51
	NAT	LG8WF21	LG8WF31	LG8WF11	LG8WF01
 angolo sx gradino plus* 35x120cm / 13 ^{3/4} "x48" rett	LAPP	LG8WF72	LG8WF82	LG8WF62	LG8WF52
	NAT	LG8WF22	LG8WF32	LG8WF12	LG8WF02
 gradino plus* 35x60cm / 13 ^{3/4} "x24" rett	GRIP	LG2WF20	LG2WF30	LG2WF10	LG2WF00
 angolo gradino plus* 35x60cm / 13 ^{3/4} "x24" rett	GRIP	LG2WF21	LG2WF31	LG2WF11	LG2WF01

* Su richiesta. Per maggiori informazioni circa quantità minime e tempi di consegna rivolgersi all'ufficio commerciale. / Upon request. For more information about minimum quantities and delivery times please contact the sales department. / Sur demande. Pour plus d'informations sur les quantités minimales et délais de livraison s'il vous plaît contacter le département des ventes. / auf Anfrage. Für weitere Infos über die Mindestmengen und Lieferzeiten wenden Sie sich bitte an unserer Verkaufsabteilung.

WATERFALL

BASKET

SILVER FLOW
gramma 16 dx
nat







DARK FLOW
gramma 66 sx
nat



MOSAICI





mosaics / mosaïques / Mosaik

Muretto	Brick	Muretto 3D	Mosaico 36
30x60cm 12"x24"	30x60cm 12"x24"	30x60cm 12"x24"	30x30cm 12"x12"

Ivory flow		NAT	LG9WFM7	LGWWF25	LGWWFD7	LGCWF25
		LAPP	LG9WFM2	LGWWF20	LGWWFD2	LGCWF20
Silver flow		NAT	LG9WFM8	LGWWF35	LGWWFD8	LGCWF35
		LAPP	LG9WFM3	LGWWF30	LGWWFD3	LGCWF30
Gray flow		NAT	LG9WFM6	LGWWF15	LGWWFD6	LGCWF15
		LAPP	LG9WFM1	LGWWF10	LGWWFD1	LGCWF10
Dark flow		NAT	LG9WFM5	LGWWF05	LGWWFD5	LGCWF05
		LAPP	LG9WFM0	LGWWF00	LGWWFD0	LGCWF00

FONDI

plain tiles / fonds / Unifliesen

Ivory flow		NAT
		LAPP
		GRIP
Silver flow		NAT
		LAPP
		GRIP
Gray flow		NAT
		LAPP
		GRIP
Dark flow		NAT
		LAPP
		GRIP

WATERFALL

GRES TUTTA MASSA UGL

Full-body porcelain / Grès Cérame pleine masse
Vollgemischtes Durchgefärbtes Feinsteinzeug

SPESSORE

Thickness / Epaisseur / Stärke

10,5 mm (30x60 - 60x60 - 45x90 - 90x90 - 90-120)
20 mm (45x90)



STONALIZZAZIONE

Shading / Denuançage / Spielfarbig

COEFFICIENTE DI ATTRITO DINAMICO B.C.R. TORTUS

$\mu > 0,40$ (nat. / grip / 20mm)

FUGA MINIMA CONSIGLIATA PER POSA IN INTERNO

Minimum suggested joint for indoor fixing
Joint minimum conseillé pour pose en enterieure
Empfohlene Fugenbreite fuer Innenbereich
2 mm

ESTERNO

Outdoor

5 mm circa / approx.

RESISTENZA ALLO SCIVOLAMENTO

Slip resistance / Résistance au glissement
Rutschfestigkeit

DIN 51130

R10 (naturale)

R11 (grip / 20mm)

RESISTENZA ALLO SCIVOLAMENTO

Slip resistance / Résistance au glissement
Rutschfestigkeit

DIN 51097

A+B (nat.)

A+B+C (grip / 20mm)

DYNAMIC COEFFICIENT OF FRICTION ANSI A 137.1:2012

DCOF \geq 0.42 (nat. / grip / 20mm)

WET PENDULUM TEST

AS 4586:2013

CLASS P4 (grip / 20mm)

IMBALLI

Packing / Emballage / Verpackung

pag. 435

P R () T E C T

ANTIBATTERICO - ANTIMICROBIAL

					Gamma 72	Gamma 66 SX	Gamma 66 DX	Gamma 16 SX	Gamma 16 DX	
30x60cm 12"x24"	60x60cm 24"x24"	45x90cm 18"x36"	90x90cm 36"x36"	60x120cm 24"x48"	49,8x16,9cm 19 ^{1/2} "x6 ^{3/8} "	39,2x19,5cm 15 ^{3/8} "x7 ^{3/8} "	39,2x19,5cm 15 ^{3/8} "x7 ^{3/8} "	19,5x9,7cm 7 ^{5/8} "x3 ^{3/4} "	19,5x9,7cm 7 ^{5/8} "x3 ^{3/4} "	45x90cm 18"x36"
rett	rett	rett	rett	rett	rett	rett	rett	rett	rett	rett
10,5 mm	10,5 mm	10,5 mm	10,5 mm	10,5 mm	10,5 mm	10,5 mm	10,5 mm	10,5 mm	10,5 mm	20 mm - SYSTEM L2
LGWVFN2	LGWVFN2	LGGWVFN2	LG9WF20	LGXWF20	LGZWF72	LGZWFS2	LGZWFD2	LG0WFS2	LG0WFD2	LG GK220
LGWVFX2	LGWVFX2	LGGWVFX2	LG9WFX2	LGXWFX2	-	-	-	-	-	-
-	LGWVWF20	-	-	-	-	-	-	-	-	-
LGWVFN3	LGWVFN3	LGGWVFN3	LG9WF30	LGXWF30	LGZWF73	LGZWFS3	LGZWFD3	LG0WFS3	LG0WFD3	LG GK230
LGWVFX3	LGWVFX3	LGGWVFX3	LG9WFX3	LGXWFX3	-	-	-	-	-	-
-	LGWVWF30	-	-	-	-	-	-	-	-	-
LGWVFN1	LGWVFN1	LGGWVFN1	LG9WF10	LGXWF10	LGZWF71	LGZWFS1	LGZWFD1	LG0WFS1	LG0WFD1	LG GK210
LGWVFX1	LGWVFX1	LGGWVFX1	LG9WFX1	LGXWFX1	-	-	-	-	-	-
-	LGWVWF10	-	-	-	-	-	-	-	-	-
LGWVFN0	LGWVFN0	LGGWVFN0	LG9WF00	LGXWF00	LGZWF70	LGZWFS0	LGZWFD0	LG0WFS0	LG0WFD0	LG GK200
LGWVFX0	LGWVFX0	LGGWVFX0	LG9WFX0	LGXWFX0	-	-	-	-	-	-
-	LGWVWF00	-	-	-	-	-	-	-	-	-

stone



GREY TENERIFE

60x90cm / 24"x36"
nat

60x60cm / 24"x24"
nat

40x60cm / 16"x24"
nat

30x60cm / 12"x24"
nat

20x60cm / 8"x24"
nat



CLIFFSTONE

220/
221

P R () T E C T
ANTIBATTERICO - ANTIMICROBIAL

7

FORMATI

sizes / formats / Formate

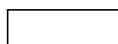

20x60cm / 8"x24" rett



30x60cm / 12"x24" rett



40x60cm / 16"x24" rett



60x60cm / 24"x24" rett



60x120cm / 24"x48" rett

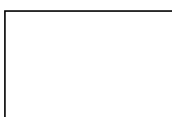

60x90cm / 24"x36" rett

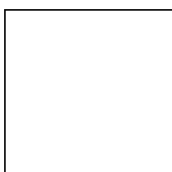

90x90cm / 36"x36" rett

SYSTEM L2

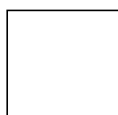

60x60cm / 24"x24" rett
20mm

4

FINITURE

finishes / surfaces / Oberfläche

LAPP

NAT

ANT

GRIP

4

COLORI

colors / couleurs / Farben

White Dover

Beige Madeira

Taupe Moher

Grey Tenerife





CLIFFSTONE

222/
223

WHITE DOVER
90x90cm / 36"x36"
lapp



stone



CLIFFSTONE

WHITE DOVER

60x120cm / 24"x48"
ant



BEIGE MADEIRA

60x90cm / 24"x36"
ant

60x60cm / 24"x24"
ant

40x60cm / 16"x24"
ant

30x60cm / 12"x24"
ant

20x60cm / 8"x24"
ant





stone



CLIFFSTONE

TAUPE MOHER

60x120cm / 24"x48"
lapp

60x90cm / 24"x36"
lapp

60x60cm / 24"x24"
lapp

30x60cm / 12"x24"
lapp



TAUPE MOHER
60x120cm / 24"x48"
nat



CLIFFSTONE

GREY TENERIFE

60x90cm / 24"x36"
nat

60x60cm / 24"x24"
nat

40x60cm / 16"x24"
nat

30x60cm / 12"x24"
nat



20x60cm / 8"x24"
nat

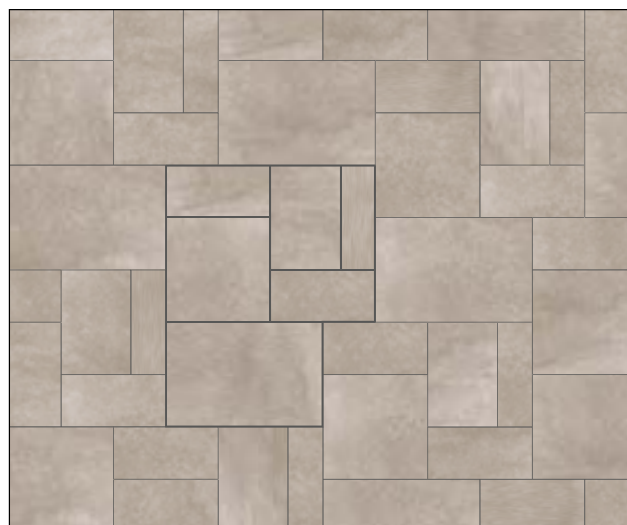

FORMATI E COLORI

sizes and colors / formats et couleurs / Formaten und Farben

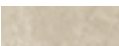
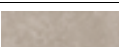
MULTIFORMATO 460x120cm - 60x90cm - 60x60cm - 30x60cm
24"x48" - 24"x36" - 24"x24" - 12"x24"**MULTIFORMATO 5**60x90cm - 60x60cm - 40x60cm - 30x60cm - 20x60cm
24"x36" - 24"x24" - 16"x24" - 12"x24" - 8"x24"**MULTIFORMATO 4**

		LAPP	NAT	ANT
		rett	rett	rett
		10 mm	10 mm	10 mm
White Dover		LG9CLWL	LG9CLWN	LG9CLW4
Beige Madeira		LG9CLBL	LG9CLBN	LG9CLB4
Taupe Moher		LG9CLTL	LG9CLTN	LG9CLT4
Grey Tenerife		LG9CLGL	LG9CLGN	LG9CLG4

MULTIFORMATO 5

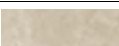
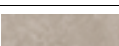
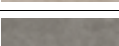
		LAPP	NAT	ANT
		rett	rett	rett
		10 mm	10 mm	10 mm
White Dover		LG9CLW5	LG9CL5W	LG9CLWA
Beige Madeira		LG9CLB5	LG9CL5B	LG9CLBA
Taupe Moher		LG9CLT5	LG9CL5T	LG9CLTA
Grey Tenerife		LG9CLG5	LG9CL5N	LG9CLGA

CLIFFSTONE

MOSAICI

mosaics / mosaïques / Mosaik

MURETTO
white dover lapp.
30x60cm / 12"x24"



MOSAICO 16
white dover lapp.
30x30cm / 12"x12"



MURETTO
beige madeira lapp.
30x60cm / 12"x24"



MOSAICO 16
beige madeira lapp.
30x30cm / 12"x12"



MURETTO
taupe moher lapp.
30x60cm / 12"x24"



MOSAICO 16
taupe moher lapp.
30x30cm / 12"x12"



MURETTO
grey tenerife lapp.
30x60cm / 12"x24"



MOSAICO 16
grey tenerife lapp.
30x30cm / 12"x12"





PEZZI SPECIALI

trims / pièces spéciales / Formstücke

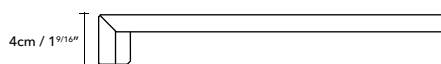
Sezione gradino

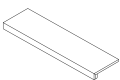
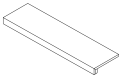
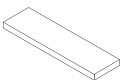

		White Dover	Beige Madeira	Taupe Moher	Grey Tenerife
 battiscopa 10x60,4cm / 4"x24"	LAPP RETT	LGBCLX3	LGBCLX0	LGBCLX2	LGBCLX1
	NAT RETT	LGBCL30	LGBCL00	LGBCL20	LGBCL10
	ANT RETT	LGBCLA3	LGBCLA0	LGBCLA2	LGBCLA1
 gradino plus* 35x120cm / 13 ^{3/4} "x48"	LAPP RETT	LG8CLX3	LG8CLX0	LG8CLX2	LG8CLX1
	NAT RETT	LG8CL30	LG8CL00	LG8CL20	LG8CL10
	ANT RETT	LG8CLA3	LG8CLA0	LG8CLA2	LG8CLA1
 angolo dx gradino plus* 35x120cm / 13 ^{3/4} "x48"	LAPP RETT	LG8CLC6	LG8CLC0	LG8CLC4	LG8CLC2
	NAT RETT	LG8CL31	LG8CL01	LG8CL21	LG8CL11
	ANT RETT	LG8CLB6	LG8CLB0	LG8CLB4	LG8CLB2
 angolo sx gradino plus* 35x120cm / 13 ^{3/4} "x48"	LAPP RETT	LG8CLC7	LG8CLC1	LG8CLC5	LG8CLC3
	NAT RETT	LG8CL32	LG8CL02	LG8CL22	LG8CL12
	ANT RETT	LG8CLB7	LG8CLB1	LG8CLB5	LG8CLB3
 gradino plus* 35x60cm / 13 ^{3/4} "x24"	GRIP RETT	LG2CL30	LG2CL00	LG2CL20	LG2CL10
 angolo sx / dx gradino plus* 35x35cm / 13 ^{3/4} "x13 ^{3/4} "	GRIP RETT	LG2CL31	LG2CL01	LG2CL21	LG2CL11

* Su richiesta. Per maggiori informazioni circa quantità minime e tempi di consegna rivolgersi all'ufficio commerciale. / Upon request. For more information about minimum quantities and delivery times please contact the sales department. / Sur demande. Pour plus d'informations sur les quantités minimales et délais de livraison s'il vous plaît contacter le département des ventes. / auf Anfrage. Für weitere Infos über die Mindestmengen und Lieferzeiten wenden Sie sich bitte an unserer Verkaufsabteilung.

CLIFFSTONE

WHITE DOVER



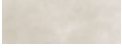

90x90cm / 36"x36"

nat



MOSAICI

mosaics / mosaïques / Mosaik

		MURETTO	MOSAICO 16
		30x60cm 12"x24"	30x30cm 12"x12"
White dover		LAPP LGVCLM3	LG9CLM3
Beige Madeira		LAPP LGVCLM0	LG9CLM0
Taupe Moher		LAPP LGVCLM2	LG9CLM2
Grey Tenerife		LAPP LGVCLM1	LG9CLM1

CLIFFSTONE

GRES TUTTA MASSA UGL

Full-body porcelain / Grès Cérame pleine masse
Vollgemischtes Durchgefärbtes Feinsteinzeug

SPESSORE

Thickness / Epaisseur / Stärke

10 mm

11 mm (90x90)



STONALIZZAZIONE

Shading / Denuançage / Spielfarbig

COEFFICIENTE DI ATTRITO DINAMICO B.C.R. TORTUS

$\mu > 0,40$

FUGA MINIMA CONSIGLIATA PER POSA IN INTERNO

Minimum suggested joint for indoor fixing
Joint minimum conseillé pour pose en interieure
Empfohlene Fugenbreite fuer Innenbereich

2 mm

RESISTENZA ALLO SCIVOLAMENTO

Slip resistance / Résistance au glissement
Rutschfestigkeit

DIN 51130

R10 (nat. / ant.)

R11 (grip)

RESISTENZA ALLO SCIVOLAMENTO

Slip resistance / Résistance au glissement
Rutschfestigkeit

DIN 51097

A+B (nat. / ant.) / A+B+C (grip)

DYNAMIC COEFFICIENT OF FRICTION ANSI A 137.1:2012

DCOF \geq 0.42

WET PENDULUM TEST

AS 4586:2013

Class P3 (nat. / ant.)

Class P4 (grip)

BRITISH PENDULUM TEST - BS 7976:2002

4S (SLIDER 96)

Dry: low slip potential PTV 36+ (nat. / ant.)

Wet: low slip potential PTV 36+ (nat. / ant.)

IMBALLI

Packing / Emballage / Verpackung

pag. 427

P R () T E C T

ANTIBATTERICO - ANTIMICROBIAL

FONDI

plain tiles / fonds / Unifliesen

		20x60cm 8"x24"	30x60cm 12"x24"	40x60cm 16"x24"	60x60cm 24"x24"	60x90cm 24"x36"	90x90cm 36"x36"	60x120cm 24"x48"	60x60cm 24"x24"
		rett	rett	rett	rett	rett	rett	rett	rett
		10 mm	10 mm	10 mm	10 mm	10 mm	11 mm	10 mm	20 mm - SYSTEM L2
White Dover	LAPP	LGKCLX3	LGVCLX3	LGJCLX3	LGWCLX3	LGACLX3	LG9CL35	LGXCLX3	-
	NAT	LGKCL30	LGVCL30	LGJCL30	LGWCL31	LGACL30	LG9CL31	LGXCL31	LGWK287
	ANT	LGKCLA3	LGVCLA3	LGJCLA3	LGWCLA3	LGACLA3	LG9CLA3	LGXCLA3	-
	GRIP	-	-	-	LGWCL35	-	-	-	-
Beige Madeira	LAPP	LGKCLX0	LGVCLX0	LGJCLX0	LGWCLX0	LGACLX0	LG9CL05	LGXCLX0	-
	NAT	LGKCL00	LGVCL00	LGJCL00	LGWCL01	LGACL00	LG9CL01	LGXCL01	LGWK281
	ANT	LGKCLA0	LGVCLA0	LGJCLA0	LGWCLA0	LGACLA0	LG9CLA0	LGXCLA0	-
	GRIP	-	-	-	LGWCL05	-	-	-	-
Taupe Moher	LAPP	LGKCLX2	LGVCLX2	LGJCLX2	LGWCLX2	LGACLX2	LG9CL25	LGXCLX2	-
	NAT	LGKCL20	LGVCL20	LGJCL20	LGWCL21	LGACL20	LG9CL21	LGXCL21	LGWK285
	ANT	LGKCLA2	LGVCLA2	LGJCLA2	LGWCLA2	LGACLA2	LG9CLA2	LGXCLA2	-
	GRIP	-	-	-	LGWCL25	-	-	-	-
Grey Tenerife	LAPP	LGKCLX1	LGVCLX1	LGJCLX1	LGWCLX1	LGACLX1	LG9CL15	LGXCLX1	-
	NAT	LGKCL10	LGVCL10	LGJCL10	LGWCL11	LGACL10	LG9CL11	LGXCL11	LGWK283
	ANT	LGKCLA1	LGVCLA1	LGJCLA1	LGWCLA1	LGACLA1	LG9CLA1	LGXCLA1	-
	GRIP	-	-	-	LGWCL15	-	-	-	-

stone



SILVER RAY
60x60cm / 24"x24"
nat



NOVA

234/
235

PROTECT
ANTIBATTERICO - ANTIMICROBIAL

4

FORMATI

sizes / formats / Formate

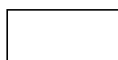

30x60cm / 12"x24" rett

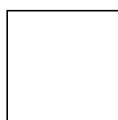

60x60cm / 24"x24" rett



30x120cm / 12"x48" rett

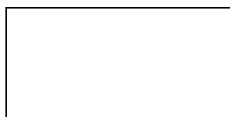

60x120cm / 24"x48" rett

2

FINITURE

finishes / surfaces / Oberfläche

NAT

GRIP

5

COLORI

colors / couleurs / Farben

Beige Stream

Cinder Flash

Taupe Shine

Grey Burst

Silver Ray

stone



NOVA

CINDER FLASH
60x60cm / 24"x24"
nat

60x60cm / 24"x24"
grip



BEYOND THE FALL



TAUPE SHINE
60x60cm / 24"x24"
nat





NOVA

GREY BURST
60x60cm / 24"x24"
nat



BEIGE STREAM
60x120cm / 24"x48"
nat



238/
239

MOSAICI









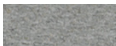

mosaics / mosaïques / Mosaik

MOSAICO GRAVITYtaupe shine
beige stream
cinder flash
silver ray
grey burst
30x60cm / 12"x24"**MOSAICO 3D**taupe shine
beige stream
cinder flash
silver ray
grey burst
28x28cm / 11"x11"**MOSAICO ANDROMEDA**taupe shine
beige stream
cinder flash
silver ray
grey burst
20x30cm / 8"x12"**BACCHETTA METAL**blue ray
gold ray
1,2x60cm / 1/2"x24"

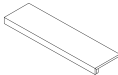
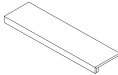
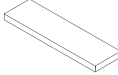
PEZZI SPECIALI

trims / pièces spéciales / Formstücke



	Beige Stream 	Cinder Flash 	Taupe Shine 	Silver Ray 	Grey Burst 
 battiscopa nat. 10x60cm / 4"x24" rett	LGBNO40	LGBNO30	LGBNO20	LGBNO10	LGBNO00
 gradino plus nat.* 35x120cm / 13 ^{3/4} "x48" rett	LG9NOP4	LG9NOP3	LG9NOP2	LG9NOP1	LG9NOP0
 angolo sx gradino plus nat.* 35x120cm / 13 ^{3/4} "x48" rett	LG9NOS4	LG9NOS3	LG9NOS2	LG9NOS1	LG9NOS0
 angolo dx gradino plus nat.* 35x120cm / 13 ^{3/4} "x48" rett	LG9NOD4	LG9NOD3	LG9NOD2	LG9NOD1	LG9NOD0
 gradino plus grip* 35x60cm / 13 ^{3/4} "x24" rett	LG9NO40	LG9NO30	LG9NO20	LG9NO10	LG9NO00
 angolo sx gradino plus grip* 35x35cm / 13 ^{3/4} "x13 ^{3/4} " rett	LG9NO4S	LG9NO3S	LG9NO2S	LG9NO1S	LG9NO0S
 angolo dx gradino plus grip* 35x35cm / 13 ^{3/4} "x13 ^{3/4} " rett	LG9NO4D	LG9NO3D	LG9NO2D	LG9NO1D	LG9NO0D
 raccordo jolly 1,3x30cm / 1/2"x12" rett	LG9NOR4	LG9NOR3	LG9NOR2	LG9NOR1	LG9NOR0
 beak jolly 1,3x2cm / 1/2"x3/4" rett	LG9NOJ4 (P01300)	LG9NOJ3 (P01300)	LG9NOJ2 (P01300)	LG9NOJ1 (P01300)	LG9NOJ0 (P01300)

* Su richiesta. Per maggiori informazioni circa quantità minime e tempi di consegna rivolgersi all'ufficio commerciale. / Upon request. For more information about minimum quantities and delivery times please contact the sales department. / Sur demande. Pour plus d'informations sur les quantités minimales et délais de livraison s'il vous plaît contacter le département des ventes. / auf Anfrage. Für weitere Infos über die Mindestmengen und Lieferzeiten wenden Sie sich bitte an unserer Verkaufsabteilung.





NOVA

BEIGE STREAM
60x120cm / 24"x48"
nat



MOSAICI

mosaics / mosaïques / Mosaik

	MOSAICO GRAVITY	MOSAICO 3D	MOSAICO ANDROMEDA
	30x60cm 12"x24"	28x28cm 11"x11"	20x30cm 8"x12"
Beige Stream	 LGVNO54	LGPNO40	LGHNO40
Cinder Flash	 LGVNO53	LGPNO30	LGHNO30
Taupe Shine	 LGVNO52	LGPNO20	LGHNO20
Silver Ray	 LGVNO51	LGPNO10	LGHNO10
Grey Burst	 LGVNO50	LGPNO00	LGHNO00

BACCHETTA METAL BLUE RAY	BACCHETTA METAL GOLD RAY
1,2x60cm 1/2"x24"	1,2x60cm 1/2"x24"
LG9NO50	LG9NO51

NOVA

GRES TUTTA MASSA UGL

Full-body porcelain / Grès Cérame pleine masse / Vollgemischtes Durchgefärbtes Feinsteinzeug

SPESSORE

Thickness / Epaisseur / Stärke
10 mm



STONALIZZAZIONE

Shading / Denuançage / Spielfarbig

**COEFFICIENTE DI ATTRITO DINAMICO
B.C.R. TORTUS**
 $\mu > 0,40$

FUGA MINIMA CONSIGLIATA PER POSA IN INTERNO

Minimum suggested joint for indoor fixing
Joint minimum conseillé pour pose en interieure
Empfohlene Fugenbreite fuer Innenbereich
2 mm

RESISTENZA ALLO SCIVOLAMENTO

Slip resistance / Résistance au glissement
Rutschfestigkeit

DIN 51130

R10 (nat.)
R11 (grip)

RESISTENZA ALLO SCIVOLAMENTO

Slip resistance / Résistance au glissement
Rutschfestigkeit

DIN 51097

A+B (nat.) / A+B+C (grip)

DYNAMIC COEFFICIENT OF FRICTION ANSI A 137.1:2012

DCOF \geq 0.42

WET PENDULUM TEST

AS 4586:2013

Class P4 (grip)

BRITISH PENDULUM TEST - BS 7976:2002

4S (SLIDER 96)

Dry: low slip potential PTV 36+ (grip)

Wet: low slip potential PTV 36+ (grip)

TRL (SLIDER 55)

Dry: low slip potential PTV 36+ (grip)

Wet: low slip potential PTV 36+ (grip)

IMBALLI



Packing / Emballage / Verpackung
pag. 431

P R () T E C T

ANTIBATTERICO - ANTIMICROBIAL

FONDI

plain tiles / fonds / Unifliesen

			30x60cm 12"x24"	60x60cm 24"x24"	30x120cm 12"x48"	60x120cm 24"x48"
			rett	rett	rett	rett
			10 mm	10 mm	10 mm	10 mm
Beige Stream		NAT	LGVNO40	LGWNO40	LG6NO40	LGXNO41
		GRIP	LGVNO45	LGWNOG4	-	-
Cinder Flash		NAT	LGVNO30	LGWNO30	LG6NO30	LGXNO31
		GRIP	LGVNO35	LGWNOG3	-	-
Taupe Shine		NAT	LGVNO20	LGWNO20	LG6NO20	LGXNO21
		GRIP	LGVNO25	LGWNOG2	-	-
Silver Ray		NAT	LGVNO10	LGWNO10	LG6NO10	LGXNO11
		GRIP	LGVNO15	LGWNOG1	-	-
Grey Burst		NAT	LGVNO00	LGWNO00	LG6NO00	LGXNO01
		GRIP	LGVNO05	LGWNOG0	-	-

stone



TEXTURE

60x60 cm / 24"x24"
nat

30x60 cm / 12"x24"
nat



BASALTINA STONE PROJECT

3

FORMATI

sizes / formats / Formate

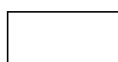

30x60 cm / 12"x24" rett



60x60cm / 24"x24" rett

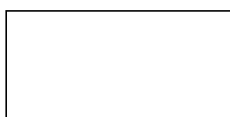

60x120cm / 24"x48" rett

2

FINITURE

finishes / surfaces / Oberfläche

NAT

LEV

7

COLORI

colors / couleurs / Farben

Scalpellata

Naturale

Sabbiata

Stuccata

Sabbiata Velvet

Lappata

Texture



BASALTINA STONE PROJECT

SCALPELLATA
30x60cm / 12"x24"
nat



STUCCATA
60x60cm / 24"x24"
nat



SCALPELLATA
30x60cm / 12"x24"
nat



246/
247



stone





BASALTINA STONE PROJECT

248/
249

LAPPATA

30x60cm / 12"x24"

mosaico 1

28,5x28,5cm / 11¹/₄"x11¹/₄"



BASALTINA STONE PROJECT

MOSAICI

mosaics / mosaïques / Mosaik

MOSAICO 1
sabbiaia
28,5x28,5cm / 11^{1/4}"x11^{1/4}"

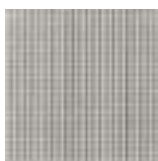

MURETTO
sabbiaia
30x60cm / 12"x24"



MOSAICO 1
sabbiaia velvet
28,5x28,5cm / 11^{1/4}"x11^{1/4}"

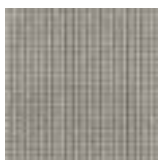

MURETTO
sabbiaia velvet
30x60cm / 12"x24"



MOSAICO 1
naturale
28,5x28,5cm / 11^{1/4}"x11^{1/4}"

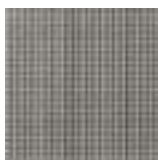

MURETTO
naturale
30x60cm / 12"x24"



MOSAICO 1
stuccata
28,5x28,5cm / 11^{1/4}"x11^{1/4}"

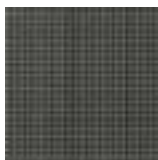

MURETTO
stuccata
30x60cm / 12"x24"



MOSAICO 1
lappata
28,5x28,5cm / 11^{1/4}"x11^{1/4}"











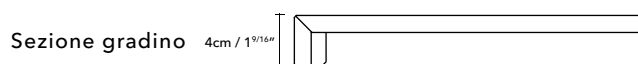









MURETTO
lappata
30x60cm / 12"x24"

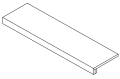

PEZZI SPECIALI

trims / pièces spéciales / Formstücke



	Scalpellata	Sabbiata	Sabbiata Velvet	Texture Nat	Texture Lev	Naturale	Stuccata	Lappata
 battiscopa 10x60cm / 4"x24" rett								
	LG9BSR6	LG9BSR0	LG9BSRE	LG9BSR7	LG9BSL7	LG9BSR1	LG9BSR2	LG9BSR3
 gradino plus* 35x120cm / 13 3/4"x48" rett	-	LG9BSP0	LG9BSP6	-	-	LG9BSP1	LG9BSP2	LG9BSP3
 angolo dx gradino plus* 35x120cm / 13 3/4"x48" rett	-	LG9BSD0	LG9BSD7	-	-	LG9BSD1	LG9BSD2	LG9BSD3
 angolo sx gradino plus* 35x120cm / 13 3/4"x48" rett	-	LG9BSS0	LG9BSS7	-	-	LG9BSS1	LG9BSS2	LG9BSS3
 gradino plus* 35x60cm / 13 3/4"x24" rett	LG9BSX6	-	-	LG9BSX7	LG9BSX8	-	-	-
 angolo dx gradino plus* 35x35cm / 13 3/4"x13 3/4" rett	LG9BSY6	-	-	LG9BSY7	LG9BSY8	-	-	-
 angolo sx gradino plus* 35x35cm / 13 3/4"x13 3/4" rett	LG9BSZ6	-	-	LG9BSZ7	LG9BSZ8	-	-	-
 raccordo jolly 1,3x30cm / 1/2"x12" rett	LG9BS36	LG9BS31	LG9BS31	LG9BS38	LG9BS37	LG9BS32	LG9BS33	LG9BS34
 beak jolly 1,3x1,3cm / 1/2"x1/2" rett	LG9BS45	LG9BS40	LG9BS40	LG9BS48	LG9BS47	LG9BS41	LG9BS42	LG9BS43

* Su richiesta. Per maggiori informazioni circa quantità minime e tempi di consegna rivolgersi all'ufficio commerciale. / Upon request. For more information about minimum quantities and delivery times please contact the sales department. / Sur demande. Pour plus d'informations sur les quantités minimales et délais de livraison s'il vous plaît contacter le département des ventes. / auf Anfrage. Für weitere Infos über die Mindestmengen und Lieferzeiten wenden Sie sich bitte an unserer Verkaufsabteilung.

BASALTINA STONE PROJECT

NATURALE
30x60cm / 12"x24"
nat







SABBIATA
60x60cm / 24"x24"
nat

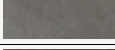

MOSAICI

mosaics / mosaïques / Mosaik

		MOSAICO 1	MURETTO
		28,5x28,5cm 11 ¹ / ₄ "x11 ¹ / ₄ "	30x60cm 12"x24"
Sabbia		LG9BS00	LG9BS05
Sabbia Velvet		LG9BS19	LG9BS49
Naturale		LG9BS01	LG9BS06
Stuccata		LG9BS02	LG9BS07
Lappata		LG9BS03	LG9BS08

BASALTINA STONE PROJECT**GRES TUTTA MASSA UGL**

Full-body porcelain / Grès Cérame pleine masse
Vollgemischtes Durchgefärbtes Feinsteinzeug

SPESORE

Thickness / Epaisseur / Stärke

11 mm (30x60 - 60x60)
12 mm (60x120)

**STONALIZZAZIONE**

Shading / Denuançage / Spielfarbig

**COEFFICIENTE DI ATTRITO DINAMICO
B.C.R. TORTUS**

$\mu > 0,40$

(sabbia / sabbia velvet / scalpellata / naturale /
stuccata / texture naturale)

WET PENDULUM TEST

AS 4586:2013

Class P4 (sabbia / scalpellata)

**FUGA MINIMA CONSIGLIATA
PER POSA IN INTERNO**

Minimum suggested joint for indoor fixing
Joint minimum conseillé pour pose en enterieure
Empfohlene Fugenbreite fuer Innenbereich
2 mm

RESISTENZA ALLO SCIVOLAMENTO

Slip resistance / Résistance au glissement
Rutschfestigkeit

DIN 51130

R10 (naturale / stuccata / texture / naturale /
sabbia / velvet)

R11 (sabbia / scalpellata)

RESISTENZA ALLO SCIVOLAMENTO

Slip resistance / Résistance au glissement
Rutschfestigkeit

DIN 51097

A+B+C (sabbia / scalpellata)

IMBALLI

Packing / Emballage / Verpackung
pag. 425

**DYNAMIC COEFFICIENT OF FRICTION
ANSI A 137.1:2012**

DCOF \geq 0.42 (naturale / stuccata / sabbia velvet)
DCOF \geq 0.62 (sabbia / scalpellata)

**BRITISH PENDULUM TEST BS 7976:2002
4S (SLIDER 96)**

Dry: low slip potential PTV 36+ (naturale /
stuccata / sabbia velvet / sabbia /
scalpellata)

Wet: moderate slip potential PTV 25-35
(naturale / stuccata / sabbia velvet)
low slip potential PTV 36+
(sabbia / scalpellata)

TRL (SLIDER 55)

Dry: low slip potential PTV 36+
(sabbia / scalpellata)

Wet: low slip potential PTV 36+
(sabbia / scalpellata)



IT / 021 / 010

FONDI

plain tiles / fonds / Unifliesen

		30x60cm 12"x24"		60x60cm 24"x24"		60x120cm 24"x48"	
		rett		rett		rett	
		11 mm		11 mm		12 mm	
Scalpellata		LGVBSR6		LGWBSR6		-	
Sabbia		LGVBSR0		LGWBSR0		LGXBSRA	
Sabbia Velvet		LGVBSRE		LGWBSRE		LGXBSRE	
Texture		NAT	LGVBSR7	LGWBSR7		-	
		LEV	LGVBSL7	LGWBSL7		-	
Naturale		LGVBSR1		LGWBSR1		LGXBSRB	
Stuccata		LGVBSR2		LGWBSR2		LGXBSRC	
Lappata		LGVBSL3		LGWBSL3		LGXBSRD	

stone



DORAL

20x30cm / 8"x12"

30x30cm / 12"x12"

30x60cm / 12"x24"



TECNOQUARTZ

254/
255**6****FORMATI**

sizes / formats / Formate



20x30cm / 8"x12" rett



30x30cm / 12"x12" rett

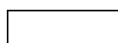

20x60cm / 8"x24" rett

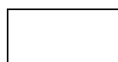

30x60cm / 12"x24" rett



40x60cm / 16"x24" rett

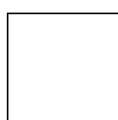

60x60cm / 24"x24" rett

4**COLORI**

colors / couleurs / Farben

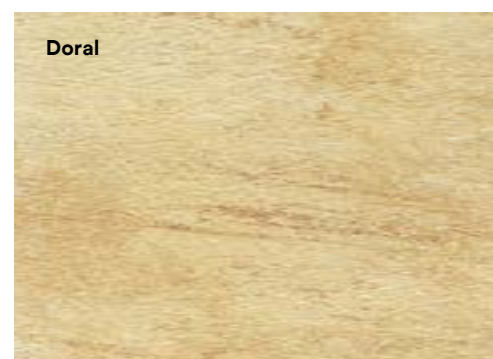
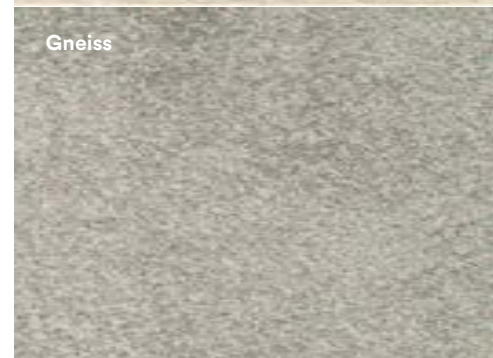
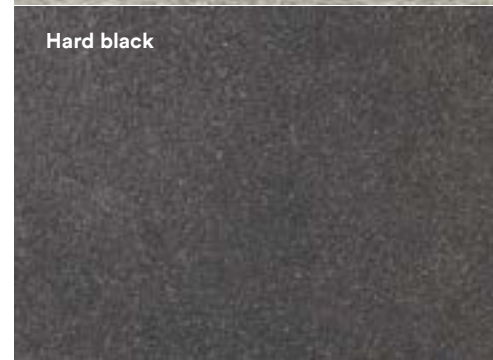
**Doral****Silver****Gneiss****Hard black**

stone





TECNOQUARTZ

SILVER

20x60cm / 8"x24"

20x30cm / 8"x12"



GNEISS

30x30cm / 12"x12"

30x60cm / 12"x24"

60x60cm / 24"x24"



TECNOQUARTZ

MOSAICI

mosaics / mosaïques / Mosaik

LISTONE LINK

doral
30x60 cm / 12"x24"



MURETTO

doral
30x60 cm / 12"x24"



MOSAICO ANTICATO 7

doral
29,3x29,3 cm / 11¹/₂"x11¹/₂"



ANTICATO 14

doral
14,5x14,5 cm / 5³/₄"x5³/₄"



ANTICATO 7x14

doral
7,1x14,5 cm / 2³/₄"x5³/₄"



LISTONE LINK
silver
30x60 cm / 12"x24"



LISTONE LINK
gneiss
30x60 cm / 12"x24"



LISTONE LINK
hard black
30x60 cm / 12"x24"



MURETTO
silver
30x60 cm / 12"x24"



MURETTO
gneiss
30x60 cm / 12"x24"



MURETTO
hard black
30x60 cm / 12"x24"



MOSAICO ANTICATO 7
silver
29,3x29,3 cm / 11¹/₂"x11¹/₂"



MOSAICO ANTICATO 7
gneiss
29,3x29,3 cm / 11¹/₂"x11¹/₂"



MOSAICO ANTICATO 7
hard black
29,3x29,3 cm / 11¹/₂"x11¹/₂"

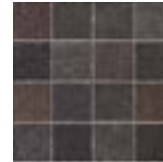

ANTICATO 14
silver
14,5x14,5 cm / 5³/₄"x5³/₄"



ANTICATO 14
gneiss
14,5x14,5 cm / 5³/₄"x5³/₄"



ANTICATO 14
hard black
14,5x14,5 cm / 5³/₄"x5³/₄"

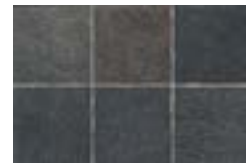

ANTICATO 7x14
silver
7,1x14,5 cm / 2³/₄"x5³/₄"



ANTICATO 7x14
gneiss
7,1x14,5 cm / 2³/₄"x5³/₄"



ANTICATO 7x14
hard black
7,1x14,5 cm / 2³/₄"x5³/₄"



TECNOQUARTZ

HARD BLACK
listone link
30x60cm / 12"x24"









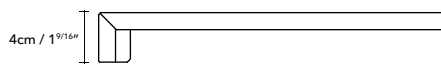



PEZZI SPECIALI

trims / pièces spéciales / Formstücke

Sezione gradino



	DORAL 	SILVER 	GNEISS 	HARD BLACK 
 battiscopa 8x30cm / 3 ¹ / ₂ "x12" rett	LGBTQ01	LGBTQ11	LGBTQ21	LGBTQ31
 gradino plus* 35x60cm / 13 ³ / ₄ "x24" rett	LG9TQP0	LG9TQP1	LG9TQP2	LG9TQP3
 angolo dx gradino plus* 35x35cm / 13 ³ / ₄ "x13 ³ / ₄ " rett	LG9TQD0	LG9TQD1	LG9TQD2	LG9TQD3
 angolo sx gradino plus* 35x35cm / 13 ³ / ₄ "x13 ³ / ₄ " rett	LG9TQS0	LG9TQS1	LG9TQS2	LG9TQS3
 elemento a elle continuo 5x15x30cm / 2"x6"x12" rett	LG9TQ64	LG9TQ63	LG9TQ65	LG9TQ67
 raccordo jolly 1,2x30cm / 1/2"x12" rett	LG9TQ26	LG9TQ27	LG9TQ31	LG9TQ52
 beak jolly 1,2x1,2cm / 1/2"x1/2" rett	LG9TQ24	LG9TQ25	LG9TQ30	LG9TQ44

* Su richiesta. Per maggiori informazioni circa quantità minime e tempi di consegna rivolgersi all'ufficio commerciale. / Upon request. For more information about minimum quantities and delivery times please contact the sales department. / Sur demande. Pour plus d'informations sur les quantités minimales et délais de livraison s'il vous plaît contacter le département des ventes. / auf Anfrage. Für weitere Infos über die Mindestmengen und Lieferzeiten wenden Sie sich bitte an unserer Verkaufsabteilung.

TECNOQUARTZ

HARD BLACK

20x30cm / 8"x12"
 20x60cm / 8"x24"
 30x30cm / 12"x12"
 30x60cm / 12"x24"
 60x60cm / 24"x24"



MOSAICI

mosaics / mosaïques / Mosaik

		Listone Link	Muretto	Mosaico Anti. 7	Anticato 14	Anticato 7x14
		30x60cm 12"x24"	30x60cm 12"x24"	29,3x29,3cm 11 ^{1/2} "x11 ^{1/2} "	14,5x14,5cm 5 ^{3/4} "x5 ^{3/4} "	7,1x14,5cm 2 ^{3/4} "x5 ^{3/4} "
Doral		LG9TQ39	LG9TQ32	LG9TQ02	LG9TQ04	LG9TQ06
Silver		LG9TQ40	LG9TQ33	LG9TQ03	LG9TQ05	LG9TQ07
Gneiss		LG9TQ38	LG9TQ34	LG9TQ09	LG9TQ28	LG9TQ29
Hard black		LG9TQ45	LG9TQ48	LG9TQ51	LG9TQ46	LG9TQ47

TECNOQUARTZ

GRES TUTTA MASSA UGL

Full-body porcelain / Grès Cérame pleine masse
Vollgemischtes Durchgefärbtes Feinsteinzeug

SPESSORE

Thickness / Epaisseur / Stärke

12 mm



STONALIZZAZIONE

Shading / Denuançage / Spielfarbig

COEFFICIENTE DI ATTRITO DINAMICO

B.C.R. TORTUS

$\mu > 0,40$

FUGA MINIMA CONSIGLIATA PER POSA IN INTERNO

Minimum suggested joint for indoor fixing
Joint minimum conseillé pour pose en enterieure
Empfohlene Fugenbreite fuer Innenbereich
2 mm

RESISTENZA ALLO SCIVOLAMENTO

Slip resistance / Résistance au glissement

Rutschfestigkeit

DIN 51130

R10 (doral / silver / gneiss)

R11 (hard black)

RESISTENZA ALLO SCIVOLAMENTO

Slip resistance / Résistance au glissement

Rutschfestigkeit

DIN 51097

A+B

DOPPIA PRESSATURA

Double pressed / Double pressage / Doppelte
pressung

DYNAMIC COEFFICIENT OF FRICTION ANSI A 137.1:2012

DCOF \geq 0.42

IMBALLI

Packing / Emballage / Verpackung

pag. 433



IT / 021 / 010

FONDI

plain tiles / fonds / Unifliesen

		20x30cm 8"x12"	30x30cm 12"x12"	20x60cm 8"x24"	30x60cm 12"x24"	40x60cm 16"x24"	60x60cm 24"x24"
		rett	rett	rett	rett	rett	rett
		12 mm	12 mm	12 mm	12 mm	12mm	12 mm
Doral		LGHTQ00	LGCTQ00	LGKTQ00	LGVTQ00	LGJTQ01	LGWTQ01
Silver		LGHTQ10	LGCTQ10	LGKTQ10	LGVTQ10	LGJTQ11	LGWTQ11
Gneiss		LGHTQ20	LGCTQ20	LGKTQ20	LGVTQ20	LGJTQ21	LGWTQ21
Hard black		LGHTQ30	LGCTQ30	LGKTQ30	LGVTQ30	LGJTQ31	LGWTQ31

stone

DORATO

20x40,4cm / 8"x16"

20x30,2cm / 8"x12"

20x20cm / 8"x8"



OUTDOOR

264/
265

3

FORMATI

sizes / formats / Formate



20x20cm / 8"x8" nat



20x30,2cm / 8"x12" nat



20x40,4cm / 8"x16" nat

2

COLORI

colors / couleurs / Farben

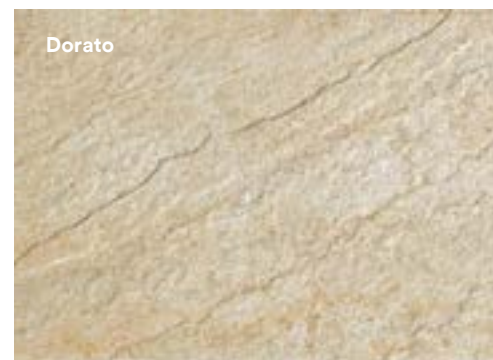

Dorato



Grigio

OUTDOOR

DORATO

20x40,4cm / 8"x16"

20x30,2cm / 8"x12"

20x20cm / 8"x8"



PEZZI SPECIALI

trims / pièces spéciales / Formstücke

	DORATO	GRIGIO
 <p>battiscopa nat. 8x30cm / 3¹/₂"x12"</p>	 LGBOD00	 LGBOD10
 <p>elemento a elle continuo nat. 5x12x30,2cm / 2"x4³/₄"x12"</p>	LG9OD00	LG9OD01

OUTDOOR

GRIGIO
20x40,4cm / 8"x16"



OUTDOOR

GRES TUTTA MASSA UGL

Full-body porcelain / Grès Cérame pleine masse / Vollgemischtes Durchgefärbtes Feinsteinzeug

SPESORE

Thickness / Epaisseur / Stärke

9 mm



STONALIZZAZIONE

Shading / Denuançage / Spielfarbig

COEFFICIENTE DI ATTRITO DINAMICO

B.C.R. TORTUS

$\mu > 0,40$

FUGA MINIMA CONSIGLIATA PER POSA IN ESTERNO

Minimum suggested joint for outdoor fixing
Joint minimum conseillé pour pose en extérieur
Empfohlene Fugenbreite fuer äußere

5 mm

RESISTENZA ALLO SCIVOLAMENTO

Slip resistance / Résistance au glissement
Rutschfestigkeit

DIN 51130

R11

RESISTENZA ALLO SCIVOLAMENTO

Slip resistance / Résistance au glissement
Rutschfestigkeit

DIN 51097

A+B+C



IMBALLI

Packing / Emballage / Verpackung

pag. 431

FONDI

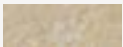
plain tiles / fonds / Unifliesen

		20×20cm 8"×8"	20×30,2cm 8"×12"	20×40,4cm 8"×16"
		nat	nat	nat
		9 mm	9 mm	9 mm
Dorato		LGL0D00	LGH0D00	LGU0D00
Grigio		LGL0D10	LGH0D10	LGU0D10

marble



**CALACATTA
SHINE**
73x73cm / 29"x29"
lux



DREAMING

270/
271

4

FORMATI

sizes / formats / Formate

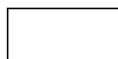

30x60cm / 12"x24" rett



60x60cm / 24"x24" rett



73x73cm / 29"x29" rett

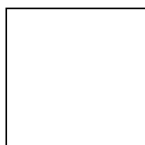

75x75cm / 30"x30" rett

2

FINITURE

finishes / surfaces / Oberfläche

LUX

VELVET

6

COLORI

colors / couleurs / Farben

Bianco Statuario



Crystal White



Calacatta Shine



Romance Safari

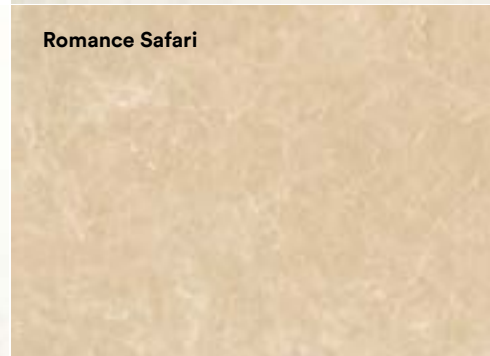

Gray Stone



Passion Pulpis



marble





DREAMING

272/
273

**CALACATTA
SHINE**
73x73cm / 29"x29"
lux



marble



DREAMING

PASSION PULPIS

73x73cm / 29"x29"
lux



ROMANCE SAFARI

75x75cm / 30"x30"
velvet





marble



DREAMING

CRYSTAL WHITE
60x60cm / 24"x24"
lux



GRAY STONE
73x73cm / 29"x29"
lux



276/
277

marble





DREAMING

SCRAPS BIANCO

60x60cm / 24"x24"

lux



BIANCO STATUARIO

73x73cm / 29"x29"

lux



DREAMING

MOSAICI

mosaics / mosaïques / Mosaik

DECORI

decors / articles / Dekore

MOSAICO BASIC
calacatta shine lux
30x30cm / 12"x12"



MOSAICO BASIC
gray stone lux
30x30cm / 12"x12"

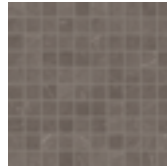

SCRAPS BIANCO
60x60cm / 24"x24"
lux



MOSAICO BASIC
romance safari lux
30x30cm / 12"x12"

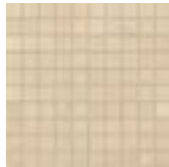

MOSAICO BASIC
bianco statuario lux
30x30cm / 12"x12"

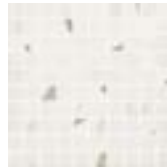

SCRAPS GRAY
60x60cm / 24"x24"
lux

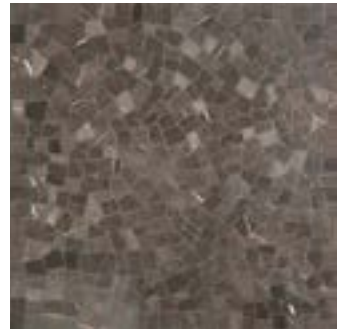

MOSAICO BASIC
crystal white lux
30x30cm / 12"x12"





MOSAICO BASIC
passion pulpis lux
30x30cm / 12"x12"

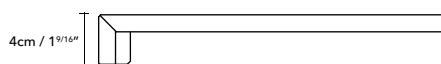

PEZZI SPECIALI

trims / pièces spéciales / Formstücke

Sezione gradino

		Bianco Statuario	Crystal White	Romance Safari	Passion Pulpis	Calacatta Shine	Gray Stone
 battiscopa 10x60cm / 4"x24" rett	LUX	LGBETX4	LGBETX0	LGBETX1	LGBETX2	LGBETX7	LGBETX8
	VELVET	LGBETR4	LGBETR0	LGBETR1	LGBETR2	LGBETR7	LGBETR8
 gradino plus* 35x60cm / 13 ^{3/4} "x24" rett	LUX	LG9ETG4	LG9ETG0	LG9ETG1	LG9ETG2	LG9ETG3	LG9ET80
	VELVET	LG9ETG9	LG9ETG5	LG9ETG6	LG9ETG7	LG9ETG8	LG9ET81
 angolo dx / sx gradino plus* 35x35cm / 13 ^{3/4} "x13 ^{3/4} " rett	LUX	LG9ETD4	LG9ETD0	LG9ETD1	LG9ETD2	LG9ETD3	LG9ET70
	VELVET	LG9ETD9	LG9ETD5	LG9ETD6	LG9ETD7	LG9ETD8	LG9ET71
 raccordo jolly 1,3x30cm / 1/2"x12" rett	LUX	LG9ETJ4	LG9ETJ0	LG9ETJ1	LG9ETJ2	LG9ETJ7	LG9ET85
	VELVET	LG9ETJ9	LG9ETJ5	LG9ETJ6	LG9ETJ3	LG9ETJ8	LG9ET86
 beak jolly 1,3x2cm / 1/2"x3/4" rett	LUX	LG9ETK4	LG9ETK0	LG9ETK1	LG9ETK2	LG9ETK3	LG9ET75
	VELVET	LG9ETK9	LG9ETK5	LG9ETK6	LG9ETK7	LG9ETK8	LG9ET76

* Su richiesta. Per maggiori informazioni circa quantità minime e tempi di consegna rivolgersi all'ufficio commerciale. / Upon request. For more information about minimum quantities and delivery times please contact the sales department. / Sur demande. Pour plus d'informations sur les quantités minimales et délais de livraison s'il vous plaît contacter le département des ventes. / auf Anfrage. Für weitere Infos über die Mindestmengen und Lieferzeiten wenden Sie sich bitte an unserer Verkaufsabteilung.

DREAMING

GRAY STONE

73x73cm / 29"x29"
lux



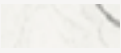
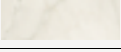
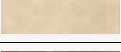
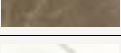
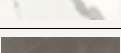
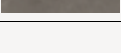

MOSAICI

mosaics / mosaïques / Mosaik

MOSAICO BASIC			
30x30cm 12"x12"			
Bianco Statuario		LUX	LG9ETM4
Crystal White		LUX	LG9ETM0
Romance Safari		LUX	LG9ETM1
Passion Pulpis		LUX	LG9ETM2
Calacatta Shine		LUX	LG9ETM7
Gray Stone		LUX	LG9ETM8

DECORI

decors / articles / Dekore

DECORO SCRAPS		
60x60cm 24"x24"		
Bianco		LGWETS4
Gray		LGWETS8

***FINITURA LUX** La presenza sporadica di piccole disuniformità o di puntini sulla superficie è da ritenersi come caratteristica del materiale e della particolare lavorazione. / LUX SURFACE FINISH The occasional presence of small inconsistencies or of little spots on the surface is to be considered a characteristic of the material and of its particular manufacture. / FINITION LUX La présence sporadique de petites déformations ou de petits points sur la surface est considérée comme caractéristique du matériau et du traitement spécial. / LUX OBERFLÄCHE Die sporadische Gegenwart von kleinen Unebenheiten oder Pünktchen auf der Oberfläche ist als Merkmal des Materials und der besonderen Fertigungsart zu betrachten.

DREAMING

GRES SMALTATO A MASSA COLORATA GL

Colored-body glazed porcelain
Grès émaillé a masse colorée
Glasiertes Feisteinzeug mit farbiger masse

SPESSORE

Thickness / Epaisseur / Stärke
10 mm (30x60 - 60x60)
11 mm (73x73 - 75x75)



STONALIZZAZIONE

Shading / Denuançage / Spielfarbig

FUGA MINIMA CONSIGLIATA PER POSA IN INTERNO

Minimum suggested joint for indoor fixing
Joint minimum conseillé pour pose en enterieure
Empfohlene Fugenbreite fuer Innenbereich
2 mm

RESISTENZA ALL'ABRASIONE SUPERFICIALE

Resistance to superficial abrasion
Résistance à l'abrasion superficielle
Oberflächliche reibungsbeständigkeit
ISO 10545-7

pei 4 lux
pei 5 velvet

DYNAMIC COEFFICIENT OF FRICTION ANSI A 137.1:2012

DCOF \geq 0.42 (velvet)

FINITURA LUX*

Lux surface finish / Finition Lux
Lux Oberfläche
Consigliato per pavimenti in ambienti residenziali.
Recommended for flooring in residential spaces.
Recommandé pour les sols dans des espaces résidentiels.
Empfohlen für Fußböden in Wohnbereichen.

FINITURA VELVET

Velvet surface finish / Finition Velvet
Velvet Oberfläche
Consigliato per pavimenti in ambienti residenziali e commerciale leggero.
Recommended for flooring in residential and low-traffic commercial spaces.
Recommandé pour les sols dans des espaces résidentiels et commerciaux (petits).
Empfohlen für Fußböden in Wohnbereichen und für leichte gewerbliche Nutzung.

IMBALLI

Packing / Emballage / Verpackung
pag. 428

FONDI

plain tiles / fonds / Unifliesen

			30x60cm	60x60cm	73x73cm	75x75cm
			12"x24"	24"x24"	29"x29"	30"x30"
			rett	rett	rett	rett
			10 mm	10 mm	11 mm	11 mm
Bianco Statuario	LUX	LGVETL4		LGWETL4	LGOET45	-
	VELVET	LGVETR4		LGWETR4	-	LGOETR4
Crystal White	LUX	LGVETX0		LGWETV0	LGOET05	-
	VELVET	LGVETR0		LGWETR0	-	LGOETR0
Romance Safari	LUX	LGVETX1		LGWETV1	LGOET15	-
	VELVET	LGVETR1		LGWETR1	-	LGOETR1
Passion Pulpis	LUX	LGVETX2		LGWETV2	LGOET25	-
	VELVET	LGVETR2		LGWETR2	-	LGOETR2
Calacatta Shine	LUX	LGVETX6		LGWETV6	LGOET65	-
	VELVET	LGVETR6		LGWETR6	-	LGOETR6
Gray Stone	LUX	LGVETX7		LGWETV7	LGOET75	-
	VELVET	LGVETR7		LGWETR7	-	LGOETR7

wood



WARM CREAM
20x180 cm / 8"x71"



BIO RECOVER

284/
285

P R () T E C T
ANTIBATTERICO - ANTIMICROBIAL

2

FORMATI

sizes / formats / Formate

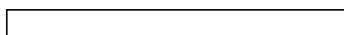

20x180 cm / 4³/₄"x71" rett



20x121,5 cm / 8"x48" nat

3

COLORI

colors / couleurs / Farben

Warm Cream

Golden Flame

Old Walnut



BIO RECOVER

WARM CREAM
20x180cm / 8"x71"

frammenti white
20x90cm / 8"x36"



286/
287



GOLDEN FLAME

ped de poule white
20x90cm / 8"x36"



wood



BIO RECOVER

OLD WALNUT

20x180cm / 8"x71"



GOLDEN FLAME

full blue
20x90cm / 8"x36"



288/
289

BIO RECOVER

DECORI

decors / articles / Dekore

PIED DE POULE WHITE
20x90cm / 8"x36"



PIED DE POULE BLUE
20x90cm / 8"x36"

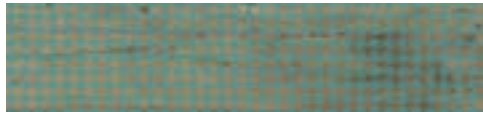

PIED DE POULE RED
20x90cm / 8"x36"



FULL WHITE
20x90cm / 8"x36"



FRAMMENTI WHITE

4x20cm / 1⁹/₁₆"x8"
8x20cm / 3¹/₈"x8"
12x20cm / 4³/₄"x8"



FULL BLUE
20x90cm / 8"x36"



FRAMMENTI BLUE

4x20cm / 1⁹/₁₆"x8"
8x20cm / 3¹/₈"x8"
12x20cm / 4³/₄"x8"



FULL RED
20x90cm / 8"x36"



FRAMMENTI RED

4x20cm / 1⁹/₁₆"x8"
8x20cm / 3¹/₈"x8"
12x20cm / 4³/₄"x8"

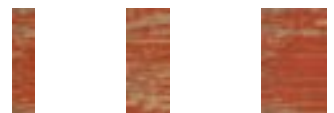

PEZZI SPECIALI

trims / pièces spéciales / Formstücke

Sezione gradino

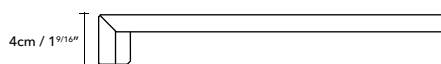

	Warm Cream 	Golden Flame 	Old Walnut 
 battiscopa 10x60cm / 4"x24" rett	LGBBR20	LGBBR00	LGBBR10
 gradino plus* 35x120cm / 13 ^{3/4} "x48" rett	LG9BRP2	LG9BRP0	LG9BRP1
 angolo dx gradino plus* 35x120cm / 13 ^{3/4} "x48" rett	LG9BRD2	LG9BRD0	LG9BRD1
 angolo sx gradino plus* 35x120cm / 13 ^{3/4} "x48" rett	LG9BRS2	LG9BRS0	LG9BRS1

* Su richiesta. Per maggiori informazioni circa quantità minime e tempi di consegna rivolgersi all'ufficio commerciale. / Upon request. For more information about minimum quantities and delivery times please contact the sales department. / Sur demande. Pour plus d'informations sur les quantités minimales et délais de livraison s'il vous plaît contacter le département des ventes. / auf Anfrage. Für weitere Infos über die Mindestmengen und Lieferzeiten wenden Sie sich bitte an unserer Verkaufsabteilung.

BIO RECOVER



GOLDEN FLAME

20x180cm / 8"x71"



DECORI

decors / articles / Dekore

	FULL WHITE	FULL BLUE	FULL RED	PIED DE POULE WHITE	PIED DE POULE BLUE	PIED DE POULE RED	FRAMMENTI WHITE	FRAMMENTI BLUE	FRAMMENTI RED
	20x90cm 8"x36"	20x90cm 8"x36"	20x90cm 8"x36"	20x90cm 8"x36"	20x90cm 8"x36"	20x90cm 8"x36"	mix	mix	mix
	12 mm	12 mm	12 mm	12 mm	12 mm	12 mm	12 mm	12 mm	12 mm
Warm Cream 	LG3BRW2	LG3BRB2	LG3BRF2	LG3BRP2	LG3BRD2	LG3BRR2	LGMBRW2	LGMBRB2	LGMBRR2
Golden Flame 	LG3BRW0	LG3BRB0	LG3BRF0	LG3BRP0	LG3BRD0	LG3BRR0	LGMBRW0	LGMBRB0	LGMBRR0
Old Walnut 	LG3BRW1	LG3BRB1	LG3BRF1	LG3BRP1	LG3BRD1	LG3BRR1	LGMBRW1	LGMBRB1	LGMBRR1

BIO RECOVER

GRES TUTTA MASSA UGL

Full-body porcelain / Grès Cérame pleine masse
Vollgemischtes Durchgefärbtes Feinsteinzeug

SPESSORE

Thickness / Epaisseur / Stärke

10,5 mm

12 mm (20x180)



STONALIZZAZIONE

Shading / Denuançage / Spielfarbig

COEFFICIENTE DI ATTRITO DINAMICO B.C.R. TORTUS

$\mu > 0,40$

FUGA MINIMA CONSIGLIATA PER POSA IN INTERNO

Minimum suggested joint for indoor fixing
Joint minimum conseillé pour pose en entérieure
Empfohlene Fugenbreite fuer Innenbereich

2 mm

RESISTENZA ALLO SCIVOLAMENTO

Slip resistance / Résistance au glissement
Rutschfestigkeit

DIN 51130

R10

RESISTENZA ALLO SCIVOLAMENTO

Slip resistance / Résistance au glissement
Rutschfestigkeit

DIN 51097

A+B

DYNAMIC COEFFICIENT OF FRICTION ANSI A 137.1:2012

DCOF \geq 0.42

IMBALLI

Packing / Emballage / Verpackung

pag. 426

P R () T E C T

ANTIBATTERICO - ANTIMICROBIAL

FONDI

plain tiles / fonds / Unifliesen

		20x180cm 8"x71"	20x121,5cm 8"x48"
		rett	nat
		12 mm	10,5 mm
Warm Cream		LG4BR20	LG0BR20
Golden Flame		LG4BR00	LG0BR00
Old Walnut		LG4BR10	LG0BR10

wood



LODGE GROVE
20x120 cm / 8"x48"

decoro cluster mix
20x20 cm / 8"x8"



BIO LUMBER

294/
295

P R () T E C T
ANTIBATTERICO - ANTIMICROBIAL

2

FORMATI

sizes / formats / Formate

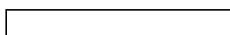

20x120 cm / 8"x48" rett

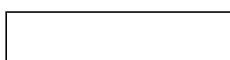

30x120cm / 12"x48" rett

SYSTEM L2

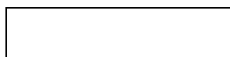

30x120cm / 12"x48" rett
±20mm

4

COLORI

colors / couleurs / Farben

Lodge Grove

Lodge Greige

Lodge Brown

Lodge Grey

wood





BIO LUMBER

296/
297

LODGE GREY
20x120cm / 8" x48"



wood





BIO LUMBER

LODGE BROWN
30x120 cm / 12"x48"
20x120 cm / 8"x48"



LODGE GROVE
20x120cm / 8"x48"
decoro cluster mix
20x20cm / 8"x8"



BIO LUMBER

DECORI

decors / articles / Dekore

CLUSTER MIX
lodge grove
20x20cm / 8"x8"



BEEHIVE
lodge grove
20x120cm / 8"x48"



CLUSTER MIX
lodge greige
20x20cm / 8"x8"



CLUSTER MIX
lodge brown
20x20cm / 8"x8"



CLUSTER MIX
lodge grey
20x20cm / 8"x8"



BEEHIVE
lodge grey
20x120cm / 8"x48"









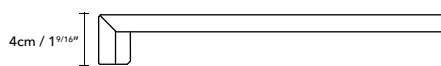

PEZZI SPECIALI

trims / pièces spéciales / Formstücke

Sezione gradino



	Lodge Grove	Lodge Greige	Lodge Brown	Lodge Grey
 battiscopa 10x60cm / 4"x24" rett				
	LGBBL30	LGBBL10	LGBBL00	LGBBL20
 gradino plus* 35x120cm / 13 ^{3/4} "x48" rett				
	LG9BL30	LG9BL10	LG9BL00	LG9BL20
 angolo dx gradino plus* 35x120cm / 13 ^{3/4} "x48" rett				
	LG9BLD3	LG9BLD1	LG9BLD0	LG9BLD2
 angolo sx gradino plus* 35x120cm / 13 ^{3/4} "x48" rett				
	LG9BLS3	LG9BLS1	LG9BLS0	LG9BLS2

* Su richiesta. Per maggiori informazioni circa quantità minime e tempi di consegna rivolgersi all'ufficio commerciale. / Upon request. For more information about minimum quantities and delivery times please contact the sales department. / Sur demande. Pour plus d'informations sur les quantités minimales et délais de livraison s'il vous plaît contacter le département des ventes. / auf Anfrage. Für weitere Infos über die Mindestmengen und Lieferzeiten wenden Sie sich bitte an unserer Verkaufsabteilung.

BIO LUMBER

LODGE GREIGE
20x120cm / 8"x48"

cluster mix lodge greige
20x20cm / 8"x8"



BIO LUMBER

GRES TUTTA MASSA UGL

Full-body porcelain / Grès Cérame pleine masse
Vollgemischtes Durchgefärbtes Feinsteinzeug

SPESSORE

Thickness / Epaisseur / Stärke

10 mm

20 mm (30x120)



STONALIZZAZIONE

Shading / Denuançage / Spielfarbig

COEFFICIENTE DI ATTRITO DINAMICO B.C.R. TORTUS

$\mu > 0,40$

FUGA MINIMA CONSIGLIATA PER POSA IN INTERNO

Minimum suggested joint for indoor fixing
Joint minimum conseillé pour pose en interieure
Empfohlene Fugenbreite fuer Innenbereich
2 mm

RESISTENZA ALLO SCIVOLAMENTO

Slip resistance / Résistance au glissement
Rutschfestigkeit

DIN 51130

R10

RESISTENZA ALLO SCIVOLAMENTO

Slip resistance / Résistance au glissement
Rutschfestigkeit

DIN 51097

A+B

DYNAMIC COEFFICIENT OF FRICTION ANSI A 137.1:2012

DCOF \geq 0.42

BRITISH PENDULUM TEST BS 7976:2002 4S (SLIDER 96)

Dry: low slip potential PTV 36+

Wet: low slip potential PTV 36+

WET PENDULUM TEST

AS 4586:2013

class P3

IMBALLI

Packing / Emballage / Verpackung

pag. 426

P R O T E C T

ANTIBATTERICO - ANTIMICROBIAL

FONDI

plain tiles / fonds / Unifliesen

		20x120cm 8"x48"	30x120cm 12"x48"	30x120cm 12"x48"
		rett	rett	rett
		10 mm	10 mm	20 mm - SYSTEM L2
Lodge Grove		LG7BL30	LG6BL30	LG6K235
Lodge Greige		LG7BL10	LG6BL10	LG6K215
Lodge Brown		LG7BL00	LG6BL00	LG6K205
Lodge Grey		LG7BL20	LG6BL20	LG6K225

DECORI

decors / articles / Dekore

		CLUSTER MIX	BEEHIVE
		20x20cm 8"x8"	20x120cm 8"x48"
Lodge Grove		LGHBL30	LG7BLB3
Lodge Greige		LGHBL10	-
Lodge Brown		LGHBL00	-
Lodge Grey		LGHBL20	LG7BLB2

wood



**OAK PATINATO
CHIARO**

20x120 cm / 8"x48"

strip
20x120cm / 8"x48"



BIO TIMBER

304/
305

P R () T E C T
ANTIBATTERICO - ANTIMICROBIAL

1

FORMATO

size / format / Format

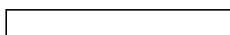

20x120 cm / 8"x48" rett

4

COLORI

colors / couleurs / Farben

Oak Patinato Chiaro



Oak Provenzale



Oak Patinato Scuro



Oak Grigio





BIO TIMBER

**OAK PATINATO
CHIARO**
20x120 cm / 8"x48"

strip
20x120cm / 8"x48"



306/
307



OAK PATINATO SCURO

20x120cm / 8"x48"



BIO TIMBER

DECORI E MOSAICI

decors and mosaics / décors et mosaïques / Dekore und Mosaïke

MOSAICO WALL
oak patinato chiaro
31x31cm / 12^{1/4}"x12^{1/4}"



COMPASS
oak patinato chiaro
20x120cm / 8"x48"



MOSAICO WALL
oak patinato scuro
31x31cm / 12^{1/4}"x12^{1/4}"



COMPASS
oak patinato scuro
20x120cm / 8"x48"



MOSAICO WALL
oak provenzale
31x31cm / 12^{1/4}"x12^{1/4}"



COMPASS
oak provenzale
20x120cm / 8"x48"



MOSAICO WALL
oak grigio
31x31cm / 12^{1/4}"x12^{1/4}"



COMPASS
oak grigio
20x120cm / 8"x48"



STRIP
oak patinato chiaro
20x120cm / 8"x48"



TRIANGLES
oak patinato chiaro
20x120cm / 8"x48"



STRIP
oak patinato scuro
20x120cm / 8"x48"



TRIANGLES
oak patinato scuro
20x120cm / 8"x48"



STRIP
oak provenzale
20x120cm / 8"x48"



TRIANGLES
oak provenzale
20x120cm / 8"x48"



STRIP
oak grigio
20x120cm / 8"x48"



TRIANGLES
oak grigio
20x120cm / 8"x48"



wood

BIO TIMBER

OAK GRIGIO

20x120cm / 8"x48"







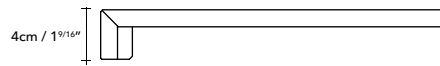

PEZZI SPECIALI

trims / pièces spéciales / Formstücke

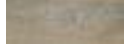
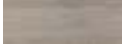
Sezione gradino



	Oak Patinato Chiaro	Oak Patinato Scuro	Oak Provenzale	Oak Grigio
 battiscopa 10x60,4cm / 4"x24" rett				
	LG9BBI00	LG9BBI10	LG9BBI20	LG9BBI40
 gradino plus* 35x120cm / 13 3/4"x48" rett				
	LG9BIG0	LG9BIG1	LG9BIG2	LG9BIG4
 angolo dx gradino plus* 35x120cm / 13 3/4"x48" rett				
	LG9BID0	LG9BID1	LG9BID2	LG9BID4
 angolo sx gradino plus* 35x120cm / 13 3/4"x48" rett				
	LG9BIS0	LG9BIS1	LG9BIS2	LG9BIS4

* Su richiesta. Per maggiori informazioni circa quantità minime e tempi di consegna rivolgersi all'ufficio commerciale. / Upon request. For more information about minimum quantities and delivery times please contact the sales department. / Sur demande. Pour plus d'informations sur les quantités minimales et délais de livraison s'il vous plaît contacter le département des ventes. / auf Anfrage. Für weitere Infos über die Mindestmengen und Lieferzeiten wenden Sie sich bitte an unserer Verkaufsabteilung.

wood

BIO TIMBER

OAK PROVENZALE
20x120cm / 8"x48"



BIO TIMBER

GRES TUTTA MASSA UGL

Full-body porcelain / Grès Cérame pleine masse
Vollgemischtes Durchgefärbtes Feinsteinzeug

SPESORE

Thickness / Epaisseur / Stärke

11 mm



STONALIZZAZIONE

Shading / Denuançage / Spielfarbig

COEFFICIENTE DI ATTRITO DINAMICO

B.C.R. TORTUS

$\mu > 0,40$

FUGA MINIMA CONSIGLIATA PER POSA IN INTERNO

Minimum suggested joint for indoor fixing
Joint minimum conseillé pour pose en interieure
Empfohlene Fugenbreite fuer Innenbereich

2 mm

RESISTENZA ALLO SCIVOLAMENTO

Slip resistance / Résistance au glissement
Rutschfestigkeit

DIN 51130

R9

DYNAMIC COEFFICIENT OF FRICTION ANSI A 137.1:2012

DCOF \geq 0.42

IMBALLI

Packing / Emballage / Verpackung





pag. 426

P R () T E C T

ANTIBATTERICO - ANTIMICROBIAL

FONDI

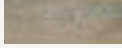
plain tiles / fonds / Unifliesen

		20x120cm 8"x48"
		rett
		11 mm
Oak Patinato Chiaro		LG7BI00
Oak Patinato Scuro		LG7BI10
Oak Provenzale		LG7BI20
Oak Grigio		LG7BI40

DECORI E MOSAICI

decors and mosaics / décors et mosaïques / Dekore und Mosaïke

		MOSAICO WALL	COMPASS	STRIP	TRIANGLES
		31x31cm 12 ^{1/4} "x12 ^{1/4} "	20x120cm 8"x48"	20x120cm 8"x48"	20x120cm 8"x48"
		11 mm	11 mm	11 mm	11 mm
Oak Patinato Chiaro		LG9BIM0	LG7BIC0	LG7BIS0	LG7BIT0
Oak Patinato Scuro		LG9BIM1	LG7BIC1	LG7BIS1	LG7BIT1
Oak Provenzale		LG9BIM2	LG7BIC2	LG7BIS2	LG7BIT2
Oak Grigio		LG9BIM4	LG7BIC4	LG7BIS4	LG7BIT4

wood



OAK NOISETTE
20x120 cm / 8"x48"



BIO PLANK

314/
315

P R () T E C T
ANTIBATTERICO - ANTIMICROBIAL

1

FORMATO

size / format / Format

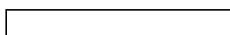

20x120 cm / 8"x48" rett

2

COLORI

colors / couleurs / Farben

Oak Ice

Oak Noisette

wood

BIO PLANK



OAK ICE
20x120cm / 8"x48"



LEA CERAMICHE



BIO PLANK

DECORI

decors / articles / Dekore

DECORO FENCE

oak ice
20x120cm / 8"x48"



DECORO FENCE

oak noisette
20x120cm / 8"x48"





PEZZI SPECIALI

trims / pièces spéciales / Formstücke

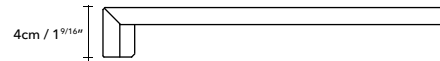
Sezione gradino

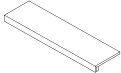
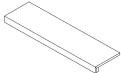
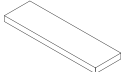

	Oak Ice	Oak Noisette
 battiscopa 10x60cm / 4"x24" rett	 LGBBPB3	 LGBBPB4
 gradino plus* 35x120cm / 13 ^{3/4} "x48" rett	LG9BPP3	LG9BPP4
 angolo dx gradino plus* 35x120cm / 13 ^{3/4} "x48" rett	LG9BPD3	LG9BPD4
 angolo sx gradino plus* 35x120cm / 13 ^{3/4} "x48" rett	LG9BPS3	LG9BPS4

* Su richiesta. Per maggiori informazioni circa quantità minime e tempi di consegna rivolgersi all'ufficio commerciale. / Upon request. For more information about minimum quantities and delivery times please contact the sales department. / Sur demande. Pour plus d'informations sur les quantités minimales et délais de livraison s'il vous plaît contacter le département des ventes. / auf Anfrage. Für weitere Infos über die Mindestmengen und Lieferzeiten wenden Sie sich bitte an unserer Verkaufsabteilung.

BIO PLANK

GRES TUTTA MASSA UGL

Full-body porcelain / Grès Cérame pleine masse
Vollgemischtes Durchgefärbtes Feinsteinzeug

SPESORE

Thickness / Epaisseur / Stärke
11 mm



STONALIZZAZIONE

Shading / Denuançage / Spielfarbig

COEFFICIENTE DI ATTRITO DINAMICO

B.C.R. TORTUS
 $\mu > 0,40$

FUGA MINIMA CONSIGLIATA PER POSA IN INTERNO

Minimum suggested joint for indoor fixing
Joint minimum conseillé pour pose en enterieure
Empfohlene Fugenbreite fuer Innenbereich
2 mm

RESISTENZA ALLO SCIVOLAMENTO

Slip resistance / Résistance au glissement
Rutschfestigkeit

DIN 51130

R9

DYNAMIC COEFFICIENT OF FRICTION ANSI A 137.1:2012

DCOF \geq 0.42

BRITISH PENDULUM TEST BS 7976:2002 4S (SLIDER 96)

Dry: low slip potential PTV 36+
Wet: moderate slip potential PTV 25-35

IMBALLI



Packing / Emballage / Verpackung
pag. 426

P R () T E C T

ANTIBATTERICO - ANTIMICROBIAL



FONDI

plain tiles / fonds / Unifliesen

		20x120cm 8"x48"
		rett
		11 mm
Oak Ice		LG7BP30
Oak Noisette		LG7BP40

DECORI

decors / articles / Dekore

		DECORO FENCE*
		20x120cm 8"x48"
		11 mm
Oak Ice*		LG7BPF3
Oak Noisette*		LG7BPF4

* Su richiesta. Per maggiori informazioni circa quantità minime e tempi di consegna rivolgersi all'ufficio commerciale. / Upon request. For more information about minimum quantities and delivery times please contact the sales department. / Sur demande. Pour plus d'informations sur les quantités minimales et délais de livraison s'il vous plaît contacter le département des ventes. / auf Anfrage. Für weitere Infos über die Mindestmengen und Lieferzeiten wenden Sie sich bitte an unserer Verkaufsabteilung.

wood



**AMERICAN
WALNUT**
20x90,5cm / 8" x36"



SUNRISE

320/
321

home
by LEA
CERAMICHE

1

FORMATO

size / format / Format



20x90,5cm / 8"x36" nat

5

COLORI

colors / couleurs / Farben

American Walnut



Australian Heat



Asian Grey



African Amber

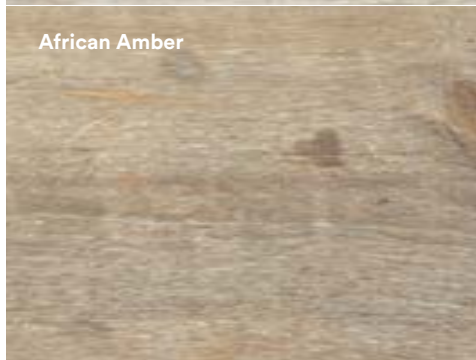

European Dark



wood



SUNRISE

AFRICAN AMBER
20x90,5cm / 8"x36"



ASIAN GREY
20x90,5cm / 8"x36"









SUNRISE

324/
325

AUSTRALIAN HEAT
20x90,5cm / 8"x36"



SUNRISE

EUROPEAN DARK
20x90,5cm / 8"x36"



SUNRISE

GRES TUTTA MASSA UGL

Full-body porcelain / Grès Cérame pleine masse
Vollgemischtes Durchgefärbtes Feinsteinzeug

SPESSORE

Thickness / Epaisseur / Stärke

10 mm



STONALIZZAZIONE

Shading / Denuançage / Spielfarbigi

COEFFICIENTE DI ATTRITO DINAMICO B.C.R. TORTUS

$\mu > 0,40$

FUGA MINIMA CONSIGLIATA PER POSA IN INTERNO

Minimum suggested joint for indoor fixing
Joint minimum conseillé pour pose en interieure
Empfohlene Fugenbreite fuer Innenbereich
4 mm

RESISTENZA ALLO SCIVOLAMENTO

Slip resistance / Résistance au glissement
Rutschfestigkeit

DIN 51130

R10

RESISTENZA ALLO SCIVOLAMENTO

Slip resistance / Résistance au glissement
Rutschfestigkeit

DIN 51097

A+B

DYNAMIC COEFFICIENT OF FRICTION ANSI A 137.1:2012

DCOF \geq 0.42

IMBALLI

Packing / Emballage / Verpackung

pag. 432





FONDI

plain tiles / fonds / Unifliesen

20x90, 8"x36"



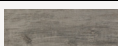

nat

10mm

Australian Heat		LG3SR40
African Amber		LG3SR30
American Walnut		LG3SR00
Asian Grey		LG3SR10
European Dark		LG3SR20

PEZZI SPECIALI

trims / pièces spéciales / Formstücke

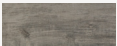
	AUSTRALIAN HEAT	AFRICAN AMBER	AMERICAN WALNUT	ASIAN GREY	EUROPEAN DARK
					
battiscopa 10x60cm / 4"x24"	LGBSR40	LGBSR30	LGBSR00	LGBSR10	LGBSR20



**MOSCOVA
ANTRACITE 3D**
30x60cm / 12"x24"



CITY

DESIGN DIEGO GRANDI

328/
329

1

FORMATO

size / format / Format



30x60cm / 12"x24" rett

2

COLORI

colors / couleurs / Farben

Moscova antracite 3D



Cordusio bronze 3D

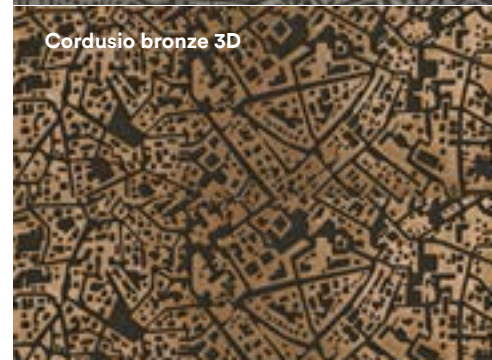

CITY

CORDUSIO BRONZE 3D
30x60cm / 12"x24"



CITY

GRES SMALTATO A MASSA COLORATA GL

Colored-body glazed porcelain
Grès émaillé a masse colorée
Glasiertes Feinsteinzeug mit farbiger masse

SPESSORE

Thickness / Epaisseur / Stärke

11 mm



FUGA MINIMA CONSIGLIATA PER POSA IN INTERNO

Minimum suggested joint for indoor fixing
Joint minimum conseillé pour pose en interieure
Empfohlene Fugenbreite fuer Innenbereich

1 mm

IMBALLI

Packing / Emballage / Verpackung

pag. 427

FONDI

plain tiles / fonds / Unifliesen

30x60cm
12"x24"

rett

11 mm

Moscova antracite 3D

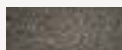

LG9CY00

Cordusio bronze 3D



LG9CY01



WHITE
single tune out matt
10x40cm / 4"x16"



2

FORMATI

sizes / formats / Formate

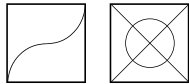

13x13cm / 5^{1/8}"x5^{1/8}" nat

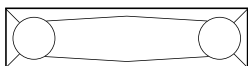

10x40cm / 4"x16" nat

2

FINITURE

finishes / surfaces / Oberfläche

GLOSSY

MATT

2

COLORI

colors / couleurs / Farben

White

Black





GOCCIA

334/
335

BLACK
double tune out glossy
10x40cm / 4"x16"





GOCCIA

WHITE

tune in glossy
13x13cm / 5¹/₈" x 5¹/₈"

tune out glossy
13x13cm / 5¹/₈" x 5¹/₈"

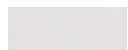

BLACK

distorsion glossy
13x13cm / 5¹/₈" x 5¹/₈"









GOCCIA

338/
339

BLACK
double tune out matt
10x40cm / 4"x16"



GOCCIA

FORMATI E COLORI

sizes and colors / formats et couleurs / Formaten und Farben

WHITE

SINGLE TUNE IN
white glossy
10x40cm / 4"x16"



SINGLE TUNE OUT
white glossy
10x40cm / 4"x16"



SINGLE TUNE IN
white matt
10x40cm / 4"x16"



SINGLE TUNE OUT
white matt
10x40cm / 4"x16"



DOUBLE TUNE IN
white gloss
10x40cm / 4"x16"



DOUBLE TUNE OUT
white gloss
10x40cm / 4"x16"



DOUBLE TUNE IN
white matt
10x40cm / 4"x16"



DOUBLE TUNE OUT
white matt
10x40cm / 4"x16"



TUNE IN
white glossy
13x13cm / 5¹/₈"x5¹/₈"



TUNE IN
white matt
13x13cm / 5¹/₈"x5¹/₈"



TUNE OUT
white glossy
13x13cm / 5¹/₈"x5¹/₈"

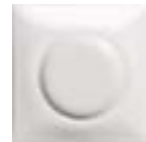

TUNE OUT
white matt
13x13cm / 5¹/₈"x5¹/₈"



DISTORSION
white glossy
13x13cm / 5¹/₈"x5¹/₈"



FORMATI E COLORI

sizes and colors / formats et couleurs / Formaten und Farben

BLACK

SINGLE TUNE IN
black glossy
10x40cm / 4"x16"



SINGLE TUNE OUT
black glossy
10x40cm / 4"x16"



SINGLE TUNE IN
black matt
10x40cm / 4"x16"



SINGLE TUNE OUT
black matt
10x40cm / 4"x16"



DOUBLE TUNE IN
black gloss
10x40cm / 4"x16"



DOUBLE TUNE OUT
black gloss
10x40cm / 4"x16"



DOUBLE TUNE IN
black matt
10x40cm / 4"x16"



DOUBLE TUNE OUT
black matt
10x40cm / 4"x16"



TUNE IN
black glossy
13x13cm / 5¹/₈"x5¹/₈"



TUNE IN
black matt
13x13cm / 5¹/₈"x5¹/₈"

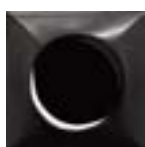

TUNE OUT
black glossy
13x13cm / 5¹/₈"x5¹/₈"



TUNE OUT
black matt
13x13cm / 5¹/₈"x5¹/₈"



DISTORSION
black glossy
13x13cm / 5¹/₈"x5¹/₈"



GOCCIA

WHITE

single tune in glossy
10x40cm / 4"x16"

single tune out glossy
10x40cm / 4"x16"

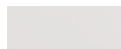

PROGETTO L14

XWHITE

glossy mood 14
10x40cm / 4"x16"

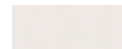

GOCCIA È ABBINABILE ALLA SERIE PROGETTO L14

Goccia can be matched with Progetto L14 / Goccia s'accorde à la collection Progetto L14
Goccia passend zu serie Progetto L14

MOOD 14
xwhite glossy
10x40cm / 4"x16"

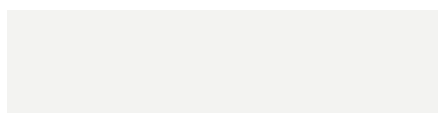

MOOD 14
xblack glossy
10x40cm / 4"x16"



MOOD 14
gesso matt
10x40cm / 4"x16"



DOUBLE 24
xwhite glossy
20x40cm / 8"x16" (preinciso 10x40cm / 4"x16")

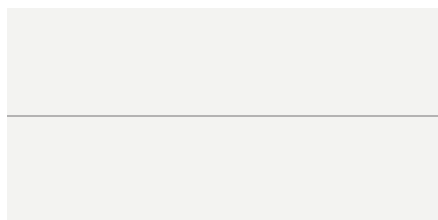

DOUBLE 24
xblack glossy
20x40cm / 8"x16" (preinciso 10x40cm / 4"x16")

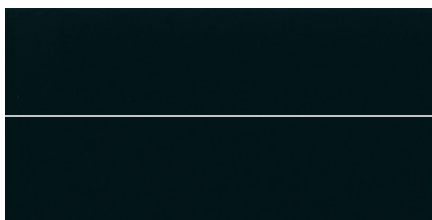

DOUBLE 24
gesso matt
20x40cm / 8"x16" (preinciso 10x40cm / 4"x16")

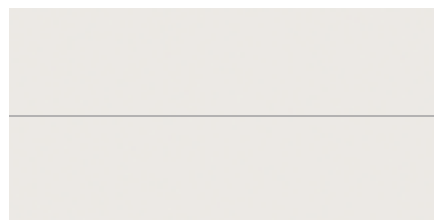

MOOD 24
xwhite glossy
20x40cm / 8"x16"

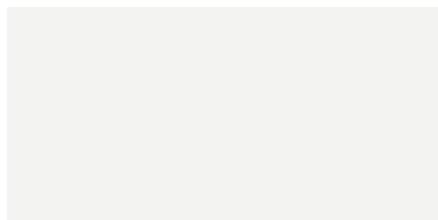

MOOD 24
xblack glossy
20x40cm / 8"x16"

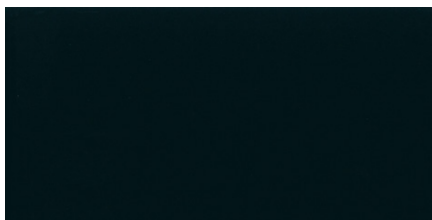

MOOD 24
gesso matt
20x40cm / 8"x16"

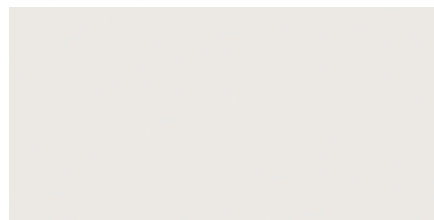
**FONDI**

plain tiles / fonds / Unifliesen

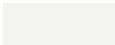
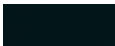
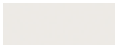
			mood 14 10x40cm 4"x16"	mood 24 20x40cm 8"x16"	double 24 (preinciso 10x40cm / 4"x16") 20x40cm 8"x16"
			nat	nat	nat
			9mm	9mm	9mm
XWhite		GLOSSY	LPDPTX0	LPNPTX0	LPNPTXD
XBlack		GLOSSY	LPDPTW0	LPNPTW0	LPNPTWD
Gesso		MATT	LPDPTI0	LPNPTI0	LPNPTID

GOCCIA

BLACK
double tune out glossy
10x40cm / 4"x16"



GOCCIA

MONOPOROSA IN PASTA BIANCA SMALTATA GL

Glazed white-body porous single-fired tiles /
Monocuissons en pâte blanche émaillé / Weiß-
cherbige monoporosa

SPESSORE

Thickness / Epaisseur / Stärke
9 mm



STONALIZZAZIONE

Shading / Denuançage / Spielfarbig

FUGA MINIMA CONSIGLIATA PER POSA IN INTERNO

Minimum suggested joint for indoor fixing
Joint minimum conseillé pour pose en interieure
Empfohlene Fugenbreite fuer Innenbereich
1 mm

IMBALLI

Packing / Emballage / Verpackung
pag. 428

FONDI

plain tiles / fonds / Unifliesen

		SINGLE TUNE IN	SINGLE TUNE OUT	DOUBLE TUNE IN	DOUBLE TUNE OUT	TUNE IN	TUNE OUT	DISTORTION
		10×40cm 4"×16"	10×40cm 4"×16"	10×40cm 4"×16"	10×40cm 4"×16"	13×13cm 5 ^{1/8"} ×5 ^{1/8"}	13×13cm 5 ^{1/8"} ×5 ^{1/8"}	13×13cm 5 ^{1/8"} ×5 ^{1/8"}
		nat	nat	nat	nat	nat	nat	nat
		9mm	9mm	9mm	9mm	9mm	9mm	9mm
White	GLOSSY	LPDGE01	LPDGE00	LPDGE06	LPDGE05	LPIGE01	LPIGE00	LPIGE0D
	MATT	LPDGE21	LPDGE20	LPDGE26	LPDGE25	LPIGE21	LPIGE20	-
Black	GLOSSY	LPDGE11	LPDGE10	LPDGE16	LPDGE15	LPIGE11	LPIGE10	LPIGE1D
	MATT	LPDGE31	LPDGE30	LPDGE36	LPDGE35	LPIGE31	LPIGE30	-



XWHITE

glossy mood 24
20x40cm / 8"x16"

glossy mood 14
10x40cm / 4"x16"

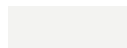

XBLACK

glossy mood 24
20x40cm / 8"x16"

glossy mood 14
10x40cm / 4"x16"

decoro spy
10x40cm / 4"x16"

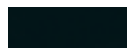

PROGETTO L14

346/
347

DESIGN GIANLUCA SODDU

3

FORMATI

sizes / formats / Formate



10x40cm / 4"x16" nat



20x40cm / 8"x16" nat



double 24
20x40cm / 8"x16" nat

2

FINITURE

finishes / surfaces / Oberfläche

GLOSSY

MATT

6

COLORI

colors / couleurs / Farben

Vaniglia

Paprika

XWhite

Gesso

XBlack

Cemento



PROGETTO L14

XWHITE

glossy mood 14
10x40cm / 4"x16"

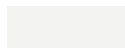

348/
349

VANIGLIA

mood 24
20x40cm / 8"x16"

mood 14
10x40cm / 4"x16"

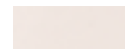

PAPRIKA

decoro spy
10x40cm / 4"x16"



PROGETTO L14

XBLACK
glossy double 24
20x40cm / 8"x16"
—
decoro spy
10x40cm / 4"x16"







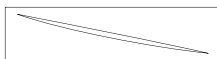

DECORI

decors / articles / Dekore

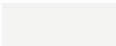
SPY
 vaniglia
 cemento
 gesso
 paprika
 xblack
 xwhite
 10x40 cm / 4"x16"

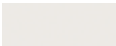
**DECORI**

decors / articles / Dekore

		SpY
		10x40cm 4"x16"
		9mm
XWhite		LPDPTX6
Vaniglia		LPDPTC6
Gesso		LPDPTI6
Cemento		LPDPTH6
XBlack		LPDPTW6
Paprika		LPDPTM6

PROGETTO L14

GESSO
deco spy
10x40cm / 4"x16"

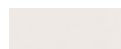

PROGETTO L14

MONOPOROSA IN PASTA BIANCA SMALTATA GL

Glazed white-body porous single-fired tiles /
Monocuissons en pâte blanche émaillé / Weiß-
cherbige monoporosa

SPESORE

Thickness / Epaisseur / Stärke
9 mm



STONALIZZAZIONE

Shading / Denuançage / Spielfarbig

FUGA MINIMA CONSIGLIATA PER POSA IN INTERNO

Minimum suggested joint for indoor fixing
Joint minimum conseillé pour pose en entérieure
Empfohlene Fugenbreite fuer Innenbereich
1 mm

IMBALLI

Packing / Emballage / Verpackung
pag. 431

FONDI

plain tiles / fonds / Unifliesen

			mood 14 10x40cm 4"x16"	mood 24 20x40cm 8"x16"	double 24 (preinciso 10x40cm / 4"x16") 20x40cm 8"x16"
			nat	nat	nat
			9mm	9mm	9mm
XWhite		GLOSSY	LPDPTX0	LPNPTX0	LPNPTXD
Vaniglia		MATT	LPDPTC0	LPNPTC0	LPNPTCD
Gesso		MATT	LPDPTI0	LPNPTI0	LPNPTID
Cemento		MATT	LPDPTH0	LPNPTH0	LPNPTH0
XBlack		GLOSSY	LPDPTW0	LPNPTW0	LPNPTWD
Paprika		GLOSSY	LPDPTM0	-	LPNPTMD

NERO

Bolli sfalsati

Curva mista

Curva diagonale
30x30cm / 12"x12"



LINK

354/
355

PERCORSI TATTILI

project for the visually-impaired or blind
série plaque tactiles pour mal voyant
programm für blinde leute

2

FORMATI

sizes / formats / Formate



20x20cm / 8"x8" nat



30x30 cm / 12"x12" nat

3

COLORI

colors / couleurs / Farben

Bianco

Nero

Giallo

FORMATI E COLORI

sizes and colors / formats et couleurs / Formaten und Farben

BOLLI SFALSATI
bianco
30x30cm / 12"x12"



BOLLI SFALSATI
nero
30x30cm / 12"x12"

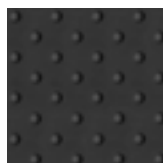

BOLLI SFALSATI
giallo
30x30cm / 12"x12"



CURVA MISTA
bianco
30x30cm / 12"x12"



CURVA MISTA
nero
30x30cm / 12"x12"

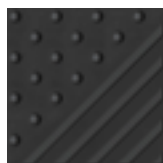

CURVA MISTA
giallo
30x30cm / 12"x12"



CURVA DIAGONALE
bianco
30x30cm / 12"x12"

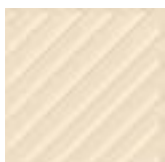

CURVA DIAGONALE
nero
30x30cm / 12"x12"

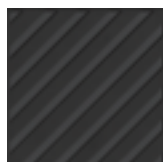

CURVA DIAGONALE
giallo
30x30cm / 12"x12"

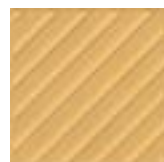

RETTILINEO
bianco
30x30cm / 12"x12"

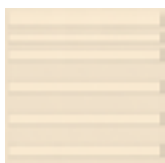

RETTILINEO
nero
30x30cm / 12"x12"



RETTILINEO
giallo
30x30cm / 12"x12"



Sezioni

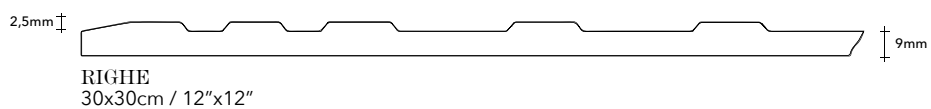
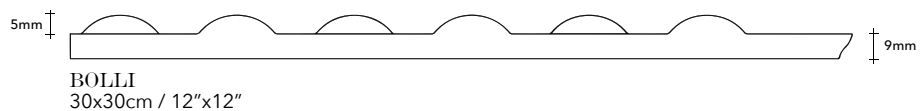

BOLLI SFALSATI 13
bianco
20x20cm / 8"x8"



BOLLI SFALSATI 13
nero
20x20cm / 8"x8"



BOLLI SFALSATI 13
giallo
20x20cm / 8"x8"



BOLLI SFALSATI 12
bianco
20x20cm / 8"x8"



BOLLI SFALSATI 12
nero
20x20cm / 8"x8"



BOLLI SFALSATI 12
giallo
20x20cm / 8"x8"



RIGHE
bianco
20x20cm / 8"x8"

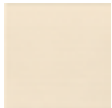

RIGHE
nero
20x20cm / 8"x8"



RIGHE
giallo
20x20cm / 8"x8"

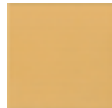

BORCHIE
bianco
20x20cm / 8"x8"

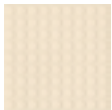

BORCHIE
nero
20x20cm / 8"x8"

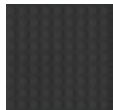

BORCHIE
giallo
20x20cm / 8"x8"



Sezioni

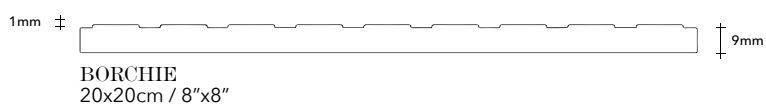
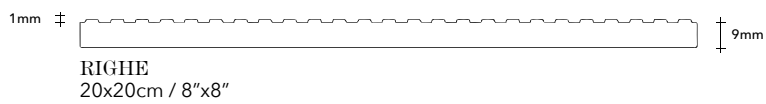
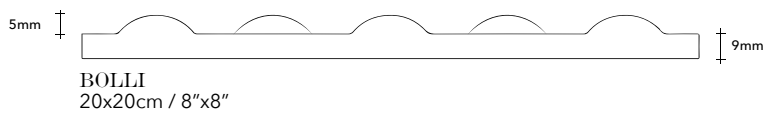

LINK

BIANCO

bolli sfalsati

curva mista

curva diagonale
30x30cm / 12"x12"



LINK**GRES TUTTA MASSA UGL**

Full-body porcelain / Grès Cérame pleine masse /
Vollgemischtes Durchgefärbtes Feinsteinzeug /

SPESSORE

Thickness / Epaisseur / Stärke
9 mm

**STONALIZZAZIONE**

Shading / Denuançage / Spielfarbig

FUGA MINIMA CONSIGLIATA

Minimum grout joint recommended
Joint minimum conseillé
Empfohlene Minimalfugenbreit
4 mm

IMBALLI

Packing / Emballage / Verpackung
pag. 429

FONDI

plain tiles / fonds / Unifliesen

		20x20cm 8"x8"		30x30cm 12"x12"	
		9 mm		9 mm	
Bianco	bolli sfalsati 13		LGHLKT0	bolli sfalsati	LG901BS
	bolli sfalsati 12		LGHLKD0	curva mista	LGPLKM0
	righe		LGHLKR0	curva diagonale	LGPLKC0
	borchie		LGHLKB0	rettilineo	LGPLKR0
Nero	bolli sfalsati 13		LGHLKT2	bolli sfalsati	LG9LK20
	bolli sfalsati 12		LGHLKD2	curva mista	LGPLKM2
	righe		LGHLKR2	curva diagonale	LGPLKC2
	borchie		LGHLKB2	rettilineo	LGPLKR2
Giallo	bolli sfalsati 13		LGHLKT1	bolli sfalsati	LG9LK10
	bolli sfalsati 12		LGHLKD1	curva mista	LGPLKM1
	righe		LGHLKR1	curva diagonale	LGPLKC1
	borchie		LGHLKB1	rettilineo	LGPLKR1



LIME L2

60x60cm / 24"x24"



CENDRE L2

60x60cm / 24"x24"



SYSTEM L2

360/361

3

FORMATI

sizes / formats / Formate

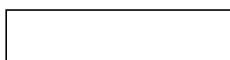

30x120cm / 12"x48" rett
±20mm



45x90cm / 18"x36" rett
±20mm

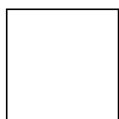

60x60cm / 24"x24" rett
±20mm

14

COLORI

colors / couleurs / Farben

WATERFALL

CLIFFSTONE

BIO LUMBER

Ivory Flow L2	White Dover L2	Lodge Grove L2
Silver Flow L2	Beige Madeira L2	Lodge Greige L2

STONECLAY

Lime L2	Gray Flow L2	Taupe Moher L2	Lodge Brown L2
Cendre L2	Dark Flow L2	Grey Tenerife L2	Lodge Grey L2

SYSTEM L2

PEZZI SPECIALI

trims / pièces spéciales / Formstücke

	WATERFALL			
	IVORY FLOW L2	SILVER FLOW L2	GRAY FLOW L2	DARK FLOW L2
 griglia* 15x45cm / 6"x18" rett	LGDK2Z2	LGDK2Z3	LGDK2Z1	LGDK2Z0
 griglia angolare dx* 15x45cm / 6"x18" rett	LGDK2A4	LGDK2A6	LGDK2A2	LGDK2A0
 gradino angolare sx* 15x45cm / 6"x18" rett	LGDK2A5	LGDK2A7	LGDK2A3	LGDK2A1
 costa toro* 30x90cm / 12"x36" rett	LGFK2F2	LGFK2F3	LGFK2F1	LGFK2F0
 costa toro angolare dx* 30x90cm / 12"x36" rett	LGFK2K4	LGFK2K6	LGFK2K2	LGFK2K0
 costa toro angolare sx* 30x90cm / 12"x36" rett	LGFK2K5	LGFK2K7	LGFK2K3	LGFK2K1
 costa retta* 30x90cm / 12"x36" rett	LGFK2C2	LGFK2C3	LGFK2C1	LGFK2C0
 costa retta angolare dx* 30x90cm / 12"x36" rett	LGFK2D4	LGFK2D6	LGFK2D2	LGFK2D0
 costa retta angolare sx* 30x90cm / 12"x36" rett	LGFK2D5	LGFK2D7	LGFK2D3	LGFK2D1
 costa toro step* 30x90cm / 12"x36" rett	LGFK2J2	LGFK2J3	LGFK2J1	LGFK2J0
 costa retta step* 30x90cm / 12"x36" rett	LGFK2G2	LGFK2G3	LGFK2G1	LGFK2G0



griglia*
15x60cm / 6"x24" rett



griglia angolare dx*
15x60cm / 6"x24" rett



gradino angolare sx*
15x60cm / 6"x24" rett



costa toro*
30x60cm / 12"x24" rett



costa toro angolare dx*
30x60cm / 12"x24" rett



costa toro angolare sx*
30x60cm / 12"x24" rett



costa retta*
30x60cm / 12"x24" rett



costa retta angolare dx*
30x60cm / 12"x24" rett



costa retta angolare sx*
30x60cm / 12"x24" rett



costa toro step*
30x60cm / 12"x24" rett



costa retta step*
30x60cm / 12"x24" rett













costa toro con gocciolatoio*
30x60cm / 12"x24" rett



costa retta con gocciolatoio*
30x60cm / 12"x24" rett

PEZZI SPECIALI

trims / pièces spéciales / Formstücke

STONECLAY		BIO LUMBER				CLIFFSTONE			
LIME L2	CENDRE L2	LODGE GROVE L2	LODGE BROWN L2	LODGE GREIGE L2	LODGE GREY L2	WHITE DOVER L2	BEIGE MADEIRA L2	TAUPE MOHER L2	GREY TENERIFE L2
									
LG1K2G0	LG1K2G1	LG1K219	LG1K203	LG1K204	LG1K220	LG1K221	LG1K222	LG1K223	LG1K224
LG1K2D0	LG1K2D1	LG1K217	LG1K208	LG1K209	LG1K218	LG1K225	LG1K227	LG1K229	LG1K230
LG1K2S0	LG1K2S1	LG1K215	LG1K213	LG1K214	LG1K216	LG1K226	LG1K228	LG1K231	LG1K232
LGVK2F0	LGVK2F1	LGVK258	LGVK228	LGVK229	LGVK259	LGVK278	LGVK279	LGVK280	LGVK281
LGVK2Y0	LGVK2Y1	LGVK254	LGVK213	LGVK214	LGVK255	LGVK2B0	LGVK2B3	LGVK2B5	LGVK2B7
LGVK2K0	LGVK2K1	LGVK256	LGVK208	LGVK209	LGVK257	LGVK2B1	LGVK2B4	LGVK2B6	LGVK2B8
LGVK2C0	LGVK2C1	LGVK260	LGVK203	LGVK204	LGVK261	LGVK290	LGVK291	LGVK292	LGVK293
LGVK2E0	LGVK2E1	LGVK250	LGVK223	LGVK224	LGVK251	LGVK2A0	LGVK2A3	LGVK2A5	LGVK2A7
LGVK2D0	LGVK2D1	LGVK252	LGVK218	LGVK219	LGVK253	LGVK2A1	LGVK2A4	LGVK2A6	LGVK2A8
LGVK2J0	LGVK2J1	LGVK268	LGVK238	LGVK239	LGVK269	LGVK270	LGVK271	LGVK272	LGVK273
LGVK2G0	LGVK2G1	LGVK264	LGVK233	LGVK234	LGVK265	LGVK286	LGVK287	LGVK288	LGVK289
LGVK2L0	LGVK2L1	LGVK266	LGVK243	LGVK244	LGVK267	LGVK274	LGVK275	LGVK276	LGVK277
LGVK2M0	LGVK2M1	LGVK262	LGVK248	LGVK249	LGVK263	LGVK282	LGVK283	LGVK284	LGVK285

* Su richiesta. Per maggiori informazioni circa quantità minime e tempi di consegna rivolgersi all'ufficio commerciale. / Upon request. For more information about minimum quantities and delivery times please contact the sales department. / Sur demande. Pour plus d'informations sur les quantités minimales et délais de livraison s'il vous plaît contacter le département des ventes. / auf Anfrage. Für weitere Infos über die Mindestmengen und Lieferzeiten wenden Sie sich bitte an unserer Verkaufsabteilung.

SYSTEM L2



SYSTEM L2

GRES TUTTA MASSA UGL

Full-body porcelain / Grès Cérame pleine masse
Vollgemischtes Durchgefärbtes Feinsteinzeug

SPESSORE

Thickness / Epaisseur / Stärke
20 mm



V2

STONALIZZAZIONE

Shading / Denuançage / Spielfarbig
(White Dover L2 - Beige Madeira L2
Taupe Shine L2 - Grey Tenerife L2)



V3

(Ivory Flow L2 - Silver Flow L2
Gray Flow L2 - Dark Flow L2
Lime L2 - Cendre L2)













V4

(Lodge Grove L2 - Lodge Greige L2
Lodge Brown L2 - Lodge Grey L2)

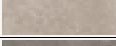
FONDI

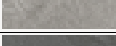
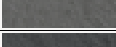
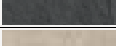
plain tiles / fonds / Unifliesen

		30x120cm 12"x48"	45x90cm 18"x36"	60x60cm 24"x24"
		rett 20 mm	rett 20 mm	rett 20 mm
Lodge Grove L2		LG6K235	-	-
Lodge Brown L2		LG6K205	-	-
Lodge Greige L2		LG6K215	-	-
Lodge Grey L2		LG6K225	-	-
White Dover L2		-	-	LGWK287
Beige Madeira L2		-	-	LGWK281
Taupe Moher L2		-	-	LGWK285
Grey Tenerife L2		-	-	LGWK283
Ivory Flow L2		-	LGGK220	-
Silver Flow L2		-	LGGK230	-
Gray Flow L2		-	LGGK210	-
Dark Flow L2		-	LGGK200	-
Lime L2		-	-	LGWK201
Cendre L2		-	-	LGWK211

INFORMAZIONI PER LA POSA

Information for laying / Informations pour la pose
Informationen zur Verlegung

Consultare il manuale "Soluzioni applicative prodotti 20mm" / Consult the manual "applicable solutions 20mm products" / Consultez le manuel « solutions applicables produits 20 mm » / Siehe Handbuch "Anwendungslösungen für 20 mm-Produkte"

RESISTENZA ALLO SCIVOLAMENTO

Slip resistance / Résistance au glissement
Rutschfestigkeit

DIN 51130

R11

RESISTENZA ALLO SCIVOLAMENTO

Slip resistance / Résistance au glissement
Rutschfestigkeit

DIN 51097

A+B+C

COEFFICIENTE DI ATTRITO DINAMICO

B.C.R. TORTUS

$\mu > 0,40$

WET PENDULUM TEST

AS 4586:2013

CLASS P4

DYNAMIC COEFFICIENT OF FRICTION

ANSI A 137.1:2012

DCOF \geq 0.42

IMBALLI

Packing / Emballage / Verpackung

pag. 433

368

370

374

386

405

406

408

425

439

443

444

legenda tecnica

TECHNICAL NOTICE - LÉGENDE TECHNIQUE
ERLÄUTERUNG DER TECHNISCHEN BEGRIFFE

lea e l'ambiente

LEA AND THE ENVIRONMENT - LEA ET L'ENVIRONNEMENT
LEA UND UMWELT

certificazioni

CERTIFICATES - LES CERTIFICATS - ZERTIFIKATE

caratteristiche tecniche

TECHNICAL SPECIFICATION - CARACTÉRISTIQUES TECHNIQUES
TECHNISCHE MERKMALE

manuali tecnici

TECHNICAL MANUALS - MANUELS TECHNIQUES
TECHNISCHE HANDBÜCHER

posa gradini ed elemento elle

INSTALLATION OF STAIR TILES AND L-ELEMENTS - POSE DES MARCHES ET DE L'ÉLÉMENT À L
VERLEGUNG DES STUFEN UND SCHENKELPLATTEN

pulizia e manutenzione

CLEANING AND MAINTENANCE - NETTOYAGE ET L'ENTRETIEN
REINIGUNG UND PFLEGE

imballi

PACKING - EMBALLAGE - VERPACKUNG

condizioni generali di vendita

GENERAL SALES CONDITIONS - CONDITIONS GENERALES DE VENTE
ALLGEMEINE VERKAUFSKONDITIONEN

disclaimer

protezione antibatterica protect

PROTECT ANTIMICROBIAL PROTECTION - PROTECT PROTECTION ANTIBACTÉRIENNE
PROTECT ANTIBAKTERIELLEN SCHUTZ

LEGENDA TECNICA

TECHNICAL NOTICE

LÉGENDE TECHNIQUE

ERLÄUTERUNG DER TECHNISCHEN BEGRIFFE

• SUPPORTO

GRES TUTTA MASSA UGL
prodotto che mostra in superficie esattamente i colori che attraversano tutto il corpo della piastrella.

GRES SMALTATO A MASSA COLORATA GL
prodotto colorato negli impasti del corpo della piastrella ulteriormente arricchito da applicazioni di smaltatura sulla superficie.

MONOPOROSA IN PASTA BIANCA SMALTATA GL
prodotto destinato al rivestimento con impasto poroso di colore biancastro, monocalibro, smaltato e colorato solo in superficie.

GRES SMALTATO GL
prodotto in gres porcellanato monocoloro di base che viene colorato in superficie esclusivamente attraverso lo smalto.

GRES LAMINATO UGL
prodotto in gres porcellanato tutta massa frutto di una tecnologia innovativa di compattazione, dotato di caratteristiche uniche di dimensioni, spessore, leggerezza, resistenza e flessibilità.

DOPPIA PRESSATURA
processo produttivo che miscela i differenti colori degli impasti del corpo piastrella in una prima pressatura e compatta i colori delle applicazioni successive attraverso una seconda ulteriore pressatura.

• BORDO

NATURALE (nat)
bordo derivato esclusivamente dalla formatura della pressa.

RETTIFICATO (rett)
bordo perfettamente rettilineo (a volte accompagnato da un lieve bisello sul perimetro di superficie) derivante da lavorazione di squadratura che riporta i pezzi ad un'unica dimensione dei lati, indipendentemente dai lotti produttivi.

• GRADO DI STONALIZZAZIONE

indica la differenza di tono delle singole piastrelle come non omogenee tra di loro.
V0 aspetto molto uniforme - V1 aspetto uniforme
V2 variazioni minime - V3 variazioni moderate
V4 variazioni sostanziali

• FINITURA DI SUPERFICIE

ANTICATA - NATURALE (nat)
TEXTURE (txt) - VELVET:
superficie che non viene in alcun modo lavorata dopo la cottura.

LUX:
finitura superficiale lucida, ottenuta tramite leggera abrasione meccanica della superficie.

LEVIGATA (lev):
finitura superficiale lucida, ottenuta asportando un piccolo strato di materiale in modo da evidenziare le caratteristiche estetiche del supporto.

LAPPATA (lapp):
superficie resa più scorrevole e lucente attraverso una lavorazione meccanica dopo la cottura.

GRIP - TEXTURE GRIP:
superficie caratterizzata da un'elevata resistenza allo scivolamento, che la rende adatta anche per applicazioni in esterno.

• FUGA

distanza consigliata tra le piastrelle.

• BASE

FULL-BODY PORCELAIN UGL
a product which has the same colours on the surface that pass through the body of the tile.

COLOURED BODY GLAZED PORCELAIN GL
a product which has a coloured body, further enhanced by glazed surface applications.

AZED WHITE-BODY POROUS SINGLE-FIRED TILES
a product designed for wall tiles with porous whitish body, single work-size, glazed and coloured only on the surface.

GLAZED PORCELAIN GL
a product in glazed, plain colour base stoneware, coloured on the surface exclusively through the glaze.

LAMINATED PORCELAIN UGL
full body porcelain produced using an innovative compacting technology, that offers unique characteristics in terms of dimension, thickness, lightness, resistance and flexibility.

DOUBLE PRESSING
a production process which combines the various colours of the tile body in a first pressing and compacts the subsequent application colours by means of a second, final pressing.

• EDGE

NATURALE (nat)
an edge produced exclusively from the moulding of the press.

RECTIFIED (rett)
a perfectly straight edge (occasionally with a slight chamfer on the surface perimeter) obtained through the process of squaring, which matches the sides of the tiles perfectly, regardless of the production lot.

• SHADING

indicates the different shades of colour between the single, non-homogeneous tiles.
V0 very uniform appearance - V1 uniform appearance
V2 slight variations - V3 moderate variations
V4 substantial variation

• SURFACE FINISH

ANTICATA - NATURALE (nat)
TEXTURE (txt) - VELVET:
a surface which is not treated in any way after firing.

LUX:
shiny superficial finish, obtained through a light mechanical abrasion of the surface.

LEVIGATA (lev):
polished surface finish, achieved by removing a small layer of material in order to highlight the aesthetic characteristics of the surface.

LAPPATA (lapp):
a smoother, shinier surface thanks to a special mechanical process after firing.

GRIP - TEXTURE GRIP:
the high coefficient of friction makes it also suitable for exterior applications.

• JOINT

recommended gap between tiles.

• SUPPORT

GRÈS PLEINE MASSE UGL
carreau présentant à la surface exactement les mêmes couleurs qui traversent toute sa masse.

GRÈS ÉMAILLÉ À MASSE COLORÉE GL
carreau coloré dans la masse dont la surface a été ensuite enrichie par des émaillages.

CARREAU MONOPOREUX ÉMAILLÉ À PÂTE BLANCHE GL
carreau à pâte poreuse de couleur blanchâtre pour le revêtement des murs, monocalibre, émaillé et coloré uniquement en surface.

GRÈS ÉMAILLÉ GL
carreau en grès cérame avec base monochrome et surface colorée uniquement par l'émail.

GRÈS LAMINÉ UGL
produit en grès cérame pleine masse fruit d'une technologie innovante de compactation, doté de caractéristique unique de dimensions, épaisseur, légèreté, résistance et flexibilité.

DOUBLE PRESSAGE
procédé de fabrication qui mélange les différentes couleurs de la masse du carreau lors d'un premier pressage et compacte les couleurs des applications suivantes par une deuxième et dernière opération de pressage.

• BORD

NATURALE (nat)
bord dont la forme n'est façonnée que par l'opération de pressage.

RECTIFIÉ (rett)
bord parfaitement rectiligne (présentant quelque fois un léger biseau au périmètre) obtenu par un équarrissage qui donne aux pièces des côtés de même taille, indépendamment des lots de production.

• VARIATION DE NUANCE

indique la différence de couleur présentée par des carreaux non homogènes.
V0 aspect très uniforme - V1 aspect uniforme
V2 variations minimales - V3 variations modérées
V4 variations importantes

• FINITION DE SURFACE

ANTICATA - NATURALE (nat)
TEXTURE (txt) - VELVET:
surface qui n'a subi aucun traitement après la cuisson.

LUX:
 finition de surface brillante, obtenue par le biais d'une légère abrasion mécanique de la surface.

LEVIGATA (lev):
 finition de surface polie, obtenue en enlevant une faible couche en superficie pour mettre en valeur les caractéristiques esthétiques du produit.

LAPPATA (lapp):
 surface rendue plus fluide et plus brillante par le biais d'un traitement mécanique après la cuisson.

GRIP - TEXTURE GRIP:
 surface avec une résistance élevée à la glissance, laquelle permet des applications en extérieur.

• JOINT

distance conseillée entre les carreaux.

• SCHERBEN

VOLLGEMISCHTES FEINSTEINZEUG UGL
ein produkt, das auf der oberfläche genau die farben zeigt, die den gesamten fliesenkörper durchziehen.

GLASIERTES FEINSTEINZEUG MIT GEFÄRBTER MASSE GL
ein produkt, bei dem die masse des fliesenkörpers gefärbt wurde und das zusätzlich eine glasur auf der oberfläche aufweist.

GLASIERTE, WEISSSCHERBIGE „MONOPOROSA“ GL
ein als wandfliese bestimmtes produkt mit poröser, weißlicher masse, das aus einem werkmaß hergestellt, glasiert und nur oberflächlich gefärbt wird.

GLASIERTES FEINSTEINZEUG GL
ein produkt aus einfarbigem grundfeinsteinzeug, das seine farbige oberfläche ausschließlich durch die glasur erhält.

LAMINIERTES FEINSTEINZEUG UGL
vollgemischtes durchgefärbtes feinsteinzeug, ergebnis einer innovativen verdichtungstechnologie. dieses produkt enthält einzigartige eigenschaften bezüglich formaten, stärke, leichtigkeit, beständigkeit und flexibilität.

DOPPELTE PRESSUNG
ein produktionsprozess, der die verschiedenen farben der massen des fliesenkörpers in einem ersten pressvorgang mischt und dann die farben in den folgenden anwendungen durch eine zweite pressung verdichtet.

• FLIESEN RAND

NATURALE (nat)
ein rand, der ausschließlich durch die formung der presse entsteht.

REKTIFIZIERTES (rett)
ein perfekt gerader rand (zum teil auch mit einer leichten abkantung an der oberfläche), der durch eine rechtwinklige bearbeitung entsteht, die die stücke, unabhängig zu welcher fertigungscharge sie gehören, auf ein übereinstimmendes seitenmaß bringt.

• FARBABSTUFUNG

gibt den unterschied der einzelnen fliesen an, deren farbtönen nicht übereinstimmt.
V0 sehr gleichmäßiges Aussehen - V1 gleichmäßiges Aussehen - V2 nur minimale Unterschiede - V3 mäßige Unterschiede - V4 bedeutende Unterschiede

• OBERFLÄCHENAUSFÜHRUNGEN

ANTICATA - NATURALE (nat)
TEXTURE (txt) - VELVET:
eine oberfläche, die nach dem brennvorgang nicht bearbeitet wird.

LUX:
lux glänzende oberfläche durch eine leicht mechanischen bearbeitung erreicht.

LEVIGATA (lev):
polierte und glänzende oberfläche, ergebnis der entfernung einer kleinen materialschicht zur betonung der ästhetischen eigenschaften der oberfläche.

LAPPATA (lapp):
eine oberfläche, die durch eine mechanische bearbeitung nach dem brennvorgang glatt und glänzend wird.

GRIP - TEXTURE GRIP:
oberfläche mit hoch rutsch festigkeit bezeichnet. für außen beriecht geeignet.

• FUGE

der zwischen den fliesen empfohlene abstand.

LEA CERAMICHE SVILUPPO ECOSOSTENIBILE

Lea Ceramiche e l'ambiente

Da sempre LEA CERAMICHE considera la tutela dell'ambiente un aspetto di grande rilevanza

- investendo in modo deciso nell'acquisto delle migliori tecnologie presenti sul mercato per ridurre al minimo gli impatti ambientali delle proprie attività
- dotando tutti i dipendenti di un ambiente di lavoro ottimale
- ottenendo prestigiose certificazioni ambientali

Le collezioni più importanti di Lea Ceramiche hanno ottenuto il prestigioso marchio ecologico

ECOLABEL (Reg. CE 66/2010), rilasciato dall'Unione Europea solo ai materiali con il più basso impatto ambientale. Tutti i prodotti LEA CERAMICHE sono realizzati presso stabilimenti produttivi dotati di **Sistemi di Gestione Ambientale certificati**:

- **ISO 14001: 2004** (norma riconosciuta a livello internazionale)
- **EMAS** (Regolamento Europeo – Reg. CE 1221/09)

Documentazioni

Le **Dichiarazioni Ambientali EMAS** dei siti produttivi, i documenti che descrivono le prestazioni degli stabilimenti in termini di salvaguardia dell'ambiente e tutti gli obiettivi che LEA CERAMICHE si pone nell'ottica del miglioramento continuo, sono disponibili sul sito Internet www.ceramichelea.it.



Lea Ceramiche salvaguardia dell'ambiente

L'incessante ricerca di prestazioni di eccellenza in merito al rispetto dell'ambiente ha condotto LEA CERAMICHE al costante rispetto dei seguenti principi.



RIUTILIZZO DEL 100% DEGLI SCARTI CRUDI

Il **100% degli scarti crudi** derivanti dal ciclo di produzione vengono **riutilizzati nella fase di preparazione dell'impasto**, contribuendo in modo sensibile alla salvaguardia delle risorse naturali riducendo l'estrazione di materie prime da cava.



RIUTILIZZO/RICICLO DEL 100% DEGLI SCARTI COTTI

Gli scarti cotti sono completamente riutilizzati nel ciclo produttivo. Inoltre, a fine vita, le piastrelle LEA CERAMICHE possono essere riciclate come inerti per sottopavimenti di strade ed edifici, riducendo così l'uso di ghiaia ed inerti naturali comunemente utilizzati in edilizia.



RICICLO DEL 100% DEI RIFIUTI NON CERAMICI

Il **100% dei rifiuti non ceramici** derivanti dalle attività produttive è **gestito in modo differenziato** e riciclato in altri processi produttivi.



RIUTILIZZO DEL 100% DELLE ACQUE DI PROCESSO

La produzione di piastrelle di ceramica richiede ingenti quantitativi di acqua. Per salvaguardare questa importante risorsa naturale LEA CERAMICHE **riutilizza il 100% delle acque reflue** derivanti dal ciclo di produzione, generando una **riduzione fino all'80% del fabbisogno idrico degli stabilimenti**.



BASSE EMISSIONI IN ATMOSFERA

Gli importanti investimenti attuati nelle migliori tecnologie a disposizione permettono di realizzare i prodotti LEA CERAMICHE **riducendo al minimo le emissioni gassose in atmosfera**, raggiungendo livelli 10 volte inferiori ai severi limiti ambientali richiesti della legislazione italiana.



FORTE RIDUZIONE DEI CONSUMI ENERGETICI

L'uso di tecnologie all'avanguardia e di soluzioni impiantistiche ottimali riducono sensibilmente l'uso di gas metano nel processo produttivo.



UTILIZZO DI IMBALLAGGI 100% RICICLABILI

I **materiali impiegati per gli imballaggi** dei prodotti LEA CERAMICHE (quali scatole, cartone, plastica, palette in legno, etc.) sono **completamente riciclabili**.



PALLET FAO

LEA CERAMICHE utilizza pallet senza cortecchia **conformi allo standard IPPC / FAO ISPM 15**, offrendo quindi ai Paesi importatori ogni garanzia per la salvaguardia del proprio patrimonio forestale.

LEA CERAMICHE 100% ECO FRIENDLY

Lea Ceramiche and the environment

Lea Ceramiche has always considered environmental protection a matter of great importance

- investing in the best technologies on the market to minimize the environmental impact of its activities
- giving all employees an excellent working environment
- obtaining prestigious environmental certifications

The most important collections of Lea Ceramiche have been awarded the prestigious **ECOLABEL** (EC regulation 66/2010), issued by the European Union only to those products with the lowest environmental impact.

All LEA CERAMICHE products are manufactured in production sites that are certified with **Environmental Management Systems**:

- **ISO 14001: 2004** (internationally recognized standard)
- **EMAS** (European Regulation - EC Reg 1221/09)

Documentation

The **EMAS Environmental Statements** of the production sites, documents describing the performance of production sites and all the objectives LEA Ceramiche strives to achieve in terms of environmental safeguard, are available on the website www.ceramichelea.it.



Lea Ceramiche cares for the environment

LEA CERAMICHE's incessant strive for excellence has led us to respect the following principles when dealing with the environment.

370/
371



100% INDUSTRIAL WASTE REUSED – NON FIRED TILES

The **totality of the non fired material**, which does not comply with our high quality standards, **is reused in the production cycle**. As these products are not yet fired, they can be reinserted in the initial phases of the production cycle. **Recycling of this waste also reduces the need of raw materials.**



100% REUSE/RECYCLING OF THE INDUSTRIAL WASTE – FIRED TILES

The waste-fired tiles are fully reused in the production cycle. In addition, at the end of life, the tiles LEA CERAMICHE can be recycled as materials for substrates for roads and buildings, thus reducing the use of gravel and natural aggregates commonly used in building.



100% INDUSTRIAL WASTE RECYCLED – NON CERAMIC WASTE

The **totality of the non ceramic waste is differentiated and recycled** in other production cycles.



100% WASTE WATER RECYCLED – SAFEGUARD OF NATURAL RESOURCES

The production of tiles requires important amounts of water. So as to safeguard this precious resource **LEA CERAMICHE recycles 100% of waste water from the production cycle. This allows the reduction of water consumption up to 80%**. None of the water used in the production cycle is discharged into the ecosystem.



LOW GAS EMISSIONS INTO THE ATMOSPHERE

LEA CERAMICHE **complies strictly to Italian Standards**. The strive for excellence has led us to invest in high quality technology that keeps **our emissions 10 times inferior the allowed limits.**



METHANE CONSUMPTION IS HIGHLY REDUCED

By the use of up to date technologies and customized installations.



100% RECYCLABLE MATERIAL USED FOR PACKING

The materials used for the packing of LEA CERAMICHE products are **completely recyclable**. These materials include carton boxes, plastic materials, wooden pallets, etc.



FAO PALLETS

For shipments LEA CERAMICHE uses debarked pallets (DB), **in accordance with the IPPC / FAO ISPM 15 standards**. This is a further warranty for the forest safeguard of countries importing LEA CERAMICHE products.

LEA CERAMICHE DÉVELOPPEMENT ÉCHO-SOSTENIBLE

Lea Ceramiche et l'environnement

Depuis toujours LEA CERAMICHE considère la protection de l'environnement un aspect très importante

- en investissant dans l'acquisition des technologies, les meilleures, pour réduire au moindre les impacts des propres activités
- donnant à tous ses employés, une ambiance de travail optimale
- obtenant des précieuses certifications

Les collectionnes les plus importantes de Lea Ceramiche ont obtenu une prestigieuse certification écologique **ECOLABEL** (Reg. CE 66/2010), Reg. NOUS 66/2010, donnée par l'union Européen seulement aux matériaux avec le plus bas impact sur l'environnement.

Tous les produits LEA CÉRAMIQUES sont fabriqués dans de sites productives doués de **Systèmes de Gestion Ambient certifiés**:

- **ISO 14001: 2004** (norme reconnue à niveau international)
- **EMAS** (Règlement européen- Reg. CE 1221/09)

Documentation

Les **Déclarations Ambientes EMAS** de sites de productions, les documents qui décrivent les performance en termes de sauvegarde de l'environnement et tous les objectifs qui se pose dans l'optique d e l'amélioration continue sont disponibles sur le site internet www.ceramichelea.it.



Lea Ceramiche preservation de l'environnement

La recherche incessante de prestations d'excellence afin de préserver l'environnement a conduit LEA CERAMICHE au suivi constant des principes suivants.



REUTILISATION DE 100 % DES DÉCHETS BRUTS

100 % des déchets bruts provenant du cycle de production sont réutilisés pendant la phase de préparation de la pâte, contribuant sensiblement à la préservation des ressources naturelles réduisant l'extraction de matières premières minières.



RÉUTILISATION/RECYCLAGE DE 100 % DES REBUTS DE CUISSON

Les rebuts de cuisson sont entièrement réutilisés dans le cycle de production. En fin de vie, les carreaux Lea Ceramiche peuvent par ailleurs être utilisés comme granulats pour les soubassements de routes et de bâtiments, ce qui permet de réduire l'utilisation de gravier et de granulats naturels habituellement utilisés en construction.



RECYCLAGE DE 100 % DES DÉCHETS NON CÉRAMIQUES

100 % des déchets non céramiques provenant des activités de production sont triés de façon sélective puis recyclés dans d'autres processus de production.



RÉUTILISATION DE 100 % DES EAUX DE TRAITEMENT

La production de carrelages demande une quantité d'eau considérable. Pour préserver cette ressource naturelle importante, LEA CERAMICHE **réutilise 100 % des eaux usées** provenant du cycle de production, ce qui permet de **réduire jusqu'à 80 % des besoins hydrauliques des usines**.



BASSES ÉMISSIONS DANS L'ATMOSPHÈRE

Les importants investissements actuels dans les meilleures technologies qui sont à notre disposition permettent de réaliser les produits LEA CERAMICHE, **en réduisant au minimum les émissions de gaz dans l'atmosphère**, et en atteignant des niveaux dix fois inférieurs aux limites environnementales très sévères fixées par la législation italienne.



FORTE RÉDUCTION DES CONSOMMATIONS ÉNERGÉTIQUES

L'utilisation de technologies de pointe et de solutions d'installations optimales permettent de réduire considérablement la consommation de gaz méthane dans le processus de production.



UTILISATION D'EMBALLAGES 100 % RECYCLABLES

Les matériaux utilisés pour les emballages des produits LEA CERAMICHE (dont des boîtes, du carton, du plastique, des palettes en bois, etc.) sont complètement recyclables.



PALETTES FAO

LEA CERAMICHE utilise des palettes sans écorce (DB) conformes aux normes IPPC / FAO ISPM 15, offrant donc aux Pays importateurs la garantie de la préservation du patrimoine forestier.

LEA CERAMICHE UMWELTSCHONENDE NACHHALTIGE ENTWICKLUNG

Lea Ceramiche und die Umwelt

Seit immer betrachtet LEA CERAMICHE den Umweltschutz als Aspekt der höchsten Relevanz

- weil sie eindeutig in der Ausstattung der besten auf dem Markt vorhandenen Technologien investiert, um die Umweltbelastung ihrer Aktivitäten drastisch zu reduzieren
- weil sie einen sauberen, optimalen Arbeitsraum allen Mitarbeitern besorgt
- weil sie wichtige, internationale Öko-Zertifikate erhält

Die wichtigsten Kollektionen von LEA CERAMICHE haben das weltberühmte Zertifikat

„**ECOLABEL**“ (Reg. CE 66/2010) erhalten, das von der Europäische Union ausschließlich den Materialien mit der geringsten Umweltbelastung ausgestellt wird.

Alle Produkte von LEA CERAMICHE sind bei Produktionsstätten hergestellt, die mit Umweltfreundlichen **Führungssystemen ausgestattet sind:**

- **ISO 14001: 2004** (weltweit anerkannte Norm)
- **EMAS** (europäische Regelung - Reg. CE 1221/09)

Unterlagen zur Information

Die **Umweltschutz-Erklärungen „EMAS“** bezüglich der Produktionsstätten d.h. die Unterlagen, die die Leistungen der Fabrikgebäude betreffend Umweltschutz + alle Ziele der LEA CERAMICHE hinsichtlich einer ständigen Verbesserung beschreiben, sind auf der Webseite www.ceramichelea.it erhältlich.



Lea Ceramiche Umweltschutz

Das unaufhörliche Bestreben nach hervorragenden Leistungen hinsichtlich der Umwelt brachte LEA CERAMICHE zur ständigen Einhaltung folgender Prinzipien.

372/
373



WIEDERVERWERTUNG VON 100 % DER ROHABFÄLLE

100% der Rohabfälle aus dem Produktionszyklus werden in der Vorbereitungsphase des Gemisches wiederverwertet und tragen somit ihren Teil zum Schutz der Naturressourcen bei, indem sie den Abbau von Rohmaterialien verringern.



WIEDERVERWENDEUNG/-VERWERTUNG ZU 100% DER BEIM BRENNEN DER FLIESEN ANFALLENDEN ABFÄLLE

Die beim Brennen der Fliesen anfallenden Abfälle werden vollständig wieder in den Produktionszyklus aufgenommen. Außerdem können die Fliesen LEA Ceramiche nach ihrem „Lebensende“ als inertes Material als Untergrund für Straßen oder Gebäude verwendet werden und somit den Einsatz von gewöhnlicherweise im Bauwesen eingesetzten Kies und inerten Naturmaterialien reduzieren.



100 % RECYCLING DES NICHT KERAMISCHEN ABFALLS

100 % der während dem Produktionsprozess anfallenden nicht **keramischen Abfälle** wird **getrennt verwaltet** und in anderen Produktionsprozessen wiederverwertet.



WIEDERVERWERTUNG VON 100 % DES ABWASSERS

Die Herstellung von Keramikfliesen erfordert beträchtliche Wassermengen. Um diese wichtige Naturressource zu schützen, verwertet LEA CERAMICHE **100 % der Abwässer des Produktionszyklus** wieder und ermöglicht somit **eine Reduktion des Wasserbedarfs in den Anlagen von bis zu 80 %**.



NIEDRIGE EMISSIONSWERTE

Dank der starken Investitionen in die modernsten, verfügbaren Produktionstechnologien ist es uns möglich, sämtliche Produkte von LEA CERAMICHE so herzustellen, dass **die Schadstoffemissionen in die Atmosphäre auf das Geringste reduziert werden.** Wir erreichen dabei ein Niveau, das 10 mal unter den strengen Grenzwerten der italienischen Gesetzgebung liegt.



BEACHTLICHE REDUZIERUNG DES ENERGIEBEDARFS

Der Einsatz fortschrittlicher Technologien und optimaler Lösungen beim Bau der Anlagen reduzieren den Einsatz von Methangas beim Produktionsprozess auf beachtliche Weise.



VERWENDUNG VON 100 % RECYCLEBAREN VERPACKUNGEN

Die Materialien, die zur Verpackung der Produkte von LEA CERAMICHE verwendet werden (Schachteln, Kartons, Kunststoffe, Holzpaletten, usw.) sind vollständig recyclebar.



FAO-PALETTE

LEA CERAMICHE verwendet gemäß dem Standard IPPC/FAO ISPM 15 Paletten ohne Rinde (DB) und gibt daher den Importländern die Garantie, den eigenen Waldbestand zu schützen.

ECOLABEL

Ecolabel è un sistema di certificazione ambientale di prodotto, creato dalla Comunità Europea (Regolamento CE n. 66/2010), che dà a tutti i consumatori la possibilità di acquistare merci eco-compatibili, contribuendo concretamente alla salvaguardia ed al miglioramento dell'eco-sistema e di conseguenza della qualità della vita. Ogni prodotto Ecolabel è contrassegnato col marchio di una margherita. Questa etichetta rappresenta un attestato di eccellenza, perché viene concessa in base a una rigorosa analisi del ciclo di vita (LCA). Per ogni prodotto vengono presi in considerazione tutti gli aspetti ambientali in ogni fase produttiva, dalle materie prime allo smaltimento: la qualità dell'aria e dell'acqua, la protezione dei suoli, la riduzione dei rifiuti, il risparmio energetico, la gestione delle risorse naturali, la protezione della fascia di ozono, l'impatto sulle biodiversità. Le piastrelle Lea Ceramiche sono materiali completamente inerti, e al termine del loro utilizzo possono essere riciclate come sottofondi di strade e edifici. Maggiori informazioni sono disponibili sul sito internet del marchio ECOLABEL <http://www.ecolabel.eu>.

Il marchio ECOLABEL è stato ottenuto da Lea Ceramiche per i prodotti appartenenti alle seguenti serie: Tecnoquartz, Basaltina Stone Project.

È in corso la certificazione ECOLABEL per l'intera gamma prodotti Lea Ceramiche.



ECOLABEL

Ecolabel is an environmental certification for a product, created by the European Union (CE n. 66/2010). It is done so as to allow all consumers to buy "green" products that are eco-compatible, and to contribute concretely to the safeguard the eco-system and improve our standard of living. All the Ecolabel products are marked with a clearly visible daisy. This label is a proof of excellence, because it is given after a thorough analysis of the product life cycle (LCA). For each product all the environmental aspects are considered in the production phase, from raw material to the destruction of the flooring: the quality of the air and water, protection of soils, reduction of waste, energy consumption, management of natural resources, protection of the ozone layer, and impact on biodiversity. Tiles by Lea Ceramiche are totally inert materials and, after their regular use, can be recycled as substrates for roads and buildings. More info available on the Ecolabel website <http://www.ecolabel.eu>.

The following collections by Lea Ceramiche have received the ecolabel certification: Tecnoquartz, Basaltina Stone Project.

We're working on ECOLABEL certification process concerning all the Lea Ceramiche range.

ECOLABEL

Ecolabel est un système de certification écologique de produit mis en place par la Communauté européenne (Règlement CE n° 66/2010). Il donne à l'ensemble des consommateurs la possibilité d'acheter des produits écologiquement efficaces et de contribuer ainsi à la sauvegarde et à l'optimisation de l'écosystème et, par conséquent, de la qualité de vie. Chaque produit Ecolabel s'accompagne d'une marguerite. Ce label constitue un certificat d'excellence, car il n'est délivré qu'après une analyse scrupuleuse du cycle de vie (ACV). Pour chaque produit, tous les aspects environnementaux sont examinés à toutes les étapes de la production, des matières premières à l'élimination des déchets : la qualité de l'air et de l'eau, la protection des sols, la réduction des déchets, l'économie d'énergie, la gestion des ressources naturelles, la protection de la couche d'ozone, l'impact sur la biodiversité. Les Produits Lea Ceramiche sont des matériaux totalement inertes, et à la fin de leur utilisation peuvent être recyclés comme les fondations de routes et de bâtiments. Plus d'informations sont disponibles sur le site de l'Ecolabel www.ecolabel.eu.

La marque Ecolabel a été obtenue par Lea Ceramiche pour les collections suivantes : Tecnoquartz, Basaltina Stone Project.

La procédure de certification ECOLABEL pour toute la gamme de produits Lea Ceramiche est en cours.

ECOLABEL

Das Ecolabel, EU-Umweltzeichen von der Europäischen Union ins Leben gerufen (Verordnung (EG) Nr. 66/2010), bietet allen Verbrauchern die Möglichkeit, umweltfreundliche Produkte zu kaufen und somit konkret zum Schutz und der Verbesserung des Ökosystems sowie der damit verbundenen Lebensqualität beizutragen. Alle Produkte, die mit diesem Zeichen ausgezeichnet sind, sind mit einer Margerite gekennzeichnet, die nach einer strengen Analyse der Produktlebensdauer gewährt wird. Bei allen Produkten werden in der Herstellungsphase alle Umweltaspekte berücksichtigt, von den Rohstoffen bis hin zur Entsorgung, Luft- und Wasserqualität, Schutz des Grundwassers, Abfallreduzierung, Energieersparnis, Management der Naturressourcen, Schutz der Ozonschicht, Auswirkung auf die biologische Vielfalt. Die Keramikfliesen von LEA CERAMICHE bestehen aus komplettem Zuschlag, sodass nach ihren Gebrauch als Untergrund von Straßenbau und Gebäuden wieder verwendet werden können. Weitere Infos bekommen Sie auf der Webseite der Marke ECOLABEL <http://www.ecolabel.eu>.

Die Marke "ECOLABEL" wurde von Lea Ceramiche fuer die Artikel folgender Serien gewonnen: Tecnoquartz, Basaltina Stone Project.

Die gesamte Serie der Produkte Lea Ceramiche durchläuft derzeit das Zertifizierungsverfahren ECOLABEL.

CERTIFICAZIONE DEL SISTEMA AMBIENTALE DEI SITI PRODUTTIVI

ENVIRONMENTAL CERTIFICATION FOR PRODUCTION SITES

CERTIFICATION DU SYSTÈME ENVIRONNEMENTAL DES SITES PRODUCTIFS

ZERTIFIZIERUNG DES UMWELTSSYSTEMS DER PRODUKTIONSSTÄTTE

CERTIQUALITY
ISTITUTO DI CERTIFICAZIONE DELLA QUALITÀ
www.certiquality.it

CERTIFICATO n. **6745**
CERTIFICATE No.

SI CERTIFICA CHE L'ORGANIZZAZIONE
HA SCELTO E CERTIFICA CHE L'ORGANIZZAZIONE
HA SCELTO E CERTIFICA CHE L'ORGANIZZAZIONE

PANARIAGROUP INDUSTRIE CERAMICHE S.p.A.

IT - 41034 FINALE EMILIA (MO) - VIA PANARIA BASSA 22/A
NE SEGUENTI SITI) IN THE FOLLOWING SITES
IT - 41034 FINALE EMILIA (MO) - VIA PANARIA BASSA 22/A
IT - 43010 TOIANO (RE) - ZONA INDUSTRIALE FORA DI CAVOLA
IT - 41042 FIORANO MODENESE (MO) - VIA CAMIAZZO 21

SI CERTIFICA CHE L'ORGANIZZAZIONE
HA SCELTO E CERTIFICA CHE L'ORGANIZZAZIONE
HA SCELTO E CERTIFICA CHE L'ORGANIZZAZIONE

UNI EN ISO 14001:2004

PER LE SEGUENTI ATTIVITÀ PER LE SEGUENTI ATTIVITÀ
EA 15

Progettazione e sviluppo, produzione attraverso le operazioni di macinazione, atomizzazione, pressatura, essiccamento, smaltatura e cottura, commercializzazione e assistenza al cliente, di piastrelle di ceramica in gres porcellanato smaltato e non smaltato.
Research and development, production through grinding, spray drying, shaping, drying, glazing and firing, sale and customer service, of glazed and unglazed porcelain ceramic tiles

Certificazione rilasciata in conformità di Regolamento Tecnico ACCREDITA 01/08
La presente certificazione è soggetta al controllo del Regolamento UNI-CERTIFICAZIONE DEI SISTEMI DI GESTIONE
The use and the validity of the certificate shall comply with the requirements of the Regulation for the construction of accreditation systems

PRIMA EMISSIONE FIRST ISSUE	24/08/2003
EMMISSIONE CORRENTE CURRENT ISSUE	30/06/2015
DATA SCADENZA VALIDITY DATE	29/06/2018

CERTIQUALITY S.p.A. - DIRETTORE GENERALE
Via S. Maria 1 - 41012 Modigliana (MO) - Italy

CISQ è la Federazione Italiana di Registratori di Certificazione dei Sistemi di Gestione Ambientale.
CISQ is the Italian Federation of registrars of environmental system certification bodies.

ACCREDITA
UNIVERSITÀ DI PADOVA

FEDERAZIONE CISQ

UNI EN ISO 14001:2004



SISTEMA DI GESTIONE AMBIENTALE CERTIFICATO

CERTIFICAZIONE AMBIENTALE EMAS DEI SITI PRODUTTIVI

Il regolamento (CE) n. 1221/2009 del Parlamento Europeo e del Consiglio, introduce il sistema comunitario di ecogestione ed audit Emas per le organizzazioni. Lea Ceramiche beneficia della Registrazione EMAS per il sito produttivo di Toano (RE), (Numero Registrazione I-000239 in data 30 Settembre 2004), per il sito produttivo di Finale Emilia (MO), (Numero Registrazione I-000309 in data 14 Aprile 2005) e per il sito produttivo di Fiorano Modenese (MO), (Numero Registrazione I-000401 in data 15 Dicembre 2005).

Questa registrazione riveste una grande importanza, perché impone la creazione di un vero Sistema di gestione Ambientale, basato sul continuo miglioramento delle proprie prestazioni ambientali.

Il sistema si basa sulla creazione di un rapporto di collaborazione e fiducia con le istituzioni del territorio (Enti, Autorità, Associazioni, Rappresentanze Sindacali, Scuole, Stampa) e con il pubblico, ed è prevista la partecipazione attiva di tutti i dipendenti.

La Dichiarazione Ambientale è il documento finale che descrive gli aspetti ambientali e di sicurezza sul lavoro, le prestazioni ambientali del sito e gli obiettivi ambientali che l'Azienda si impone di raggiungere nell'ottica del miglioramento continuo.

La dichiarazione è convalidata da un Verificatore Ambientale Accreditato, a seguito verifiche ispettive (audit) eseguite in stabilimento, ed è disponibile sul sito www.ceramichelea.it.

Lea Ceramiche, attenta alle problematiche a salvaguardia dell'ambiente, produce le proprie piastrelle presso stabilimenti Panariagroup che hanno ottenuto le due Certificazioni Ambientali ISO 14001 e Registrazione EMAS, a testimonianza della massima attenzione e sensibilità del management alle questioni etiche, ambientali e di sicurezza.

ENVIRONMENTAL CERTIFICATION EMAS FOR PRODUCTION SITES

EC Regulation no. 1221/2009 of the European Parliament and of the Council introduced the EMAS eco-management and audit scheme for organisations. Lea Ceramiche benefits from Registration EMAS for the Toano (RE) production site (Number Registration I – 000239 on date 30th September 2004), for the Finale Emilia (MO) production site (Number Registration I – 000309 on date 14th April 2005) and for the Fiorano Modenese (MO) production site (Number Registration I – 000401 on date 15th December 2005). This registration is of major importance, since it requires a proper Environmental Management System to be created, based on the continual improvement of environmental performance within organisations. The scheme is based on the creation of an open dialogue with local institutions (Agencies, Authorities, Associations, Trade Union Representatives, Schools, Press) and with the public, and it is expected that all employees will play an active part. The Environmental Statement is the end document that describes the environmental and safety aspects in the workplace, the environmental performance of the site and the environmental targets that the Company sets itself within the framework of continual improvement. The statement is validated by an Accredited Environmental Verifier, following audits carried out in the plant, it's also available on the website www.ceramichelea.it. Lea Ceramiche, caring for environment protection, produces its tiles in its plants Panariagroup, that obtained two environmental certifications ISO 14001 and the Registration EMAS. This proves the great attention and sensitiveness of our management towards ethic, environmental, and safety issues.

CERTIFICATION ENVIRONNEMENTALE EMAS DES SITES PRODUCTIFS

Le règlement (CE) n° 1221/2009 du Parlement Européen et du Conseil introduit le système communautaire de management environnemental et d'audit (EMAS) pour les organisations. Lea Ceramiche bénéficie de l'accréditation EMAS pour le site de Toano (RE) (Numero Enregistrement I – 000239 en date 30 Septembre 2004), pour le site de Finale Emilia (MO) (Numero Enregistrement I – 000309 en date 14 Avril 2005) et pour le site de Fiorano Modenese (MO) (Numero Enregistrement I – 000401 en date 15 Décembre 2005). Le système repose sur la création d'un rapport de collaboration et de confiance avec les institutions du territoire (Institutions, Pouvoirs publics, Associations, Représentations syndicales, Écoles, Presses) et avec le public. Il est prévu que tous les employés participeront activement à ce programme. La Déclaration environnementale constitue le document final décrivant les éléments en matière d'environnement et de sécurité sur le lieu de travail, les efforts effectués par le site pour l'environnement et les objectifs que l'entreprise s'est fixés dans le cadre de cette amélioration perpétuelle. La déclaration a été validée par un Contrôleur officiel suite aux inspections (audit) effectuées et est disponible sur le site www.ceramichelea.it. Lea Ceramiche, attentive aux problématiques à sauvegarde de l'environnement, produit ses carreaux dans les établissements Panariagroup qui ont obtenus les deux Certifications pour l'environnement ISO 14001 et l'accréditation EMAS, à témoignage de la plus grande attention et de la sensibilité de la part de la direction en ce qui concerne les questions éthiques, environnementales, de sécurité et de qualité.

EMAS-ZERTIFIZIERUNG (UMWELTMANAGEMENT UND UMWELTBETRIEBSPRÜFUNG) DER PRODUKTIONSSTÄTTE

Die Verordnung (EG) 1221/2009 des Europäischen Parlaments und des Rats führt ein Gemeinschaftssystem für das Umweltmanagement und die Umweltbetriebsprüfung (EMAS) für Organisationen ein. Lea Ceramiche profitiert vom EMAS – Registrierung für die Produktionsstätte Toano (RE) (Registrationsnummer I – 000239 vom 30. September 2004), für die Produktionsstätte Finale Emilia (MO) (Registrationsnummer I – 000309 vom 14. April 2005) und für die Produktionsstätte Fiorano Modenese (MO) (Registrationsnummer I – 000401 vom 15. Dezember 2005). Diese Registrierung hat eine große Bedeutung, da sie die Schaffung eines wahren Umweltmanagement-systems auf der Grundlage der kontinuierlichen Verbesserung der Effizienz des Umweltcontrollings impliziert. Das System basiert auf dem Aufbau einer kooperativen und von gegenseitigem Vertrauen geprägten Beziehung mit den territorialen Institutionen (öffentlichen Einrichtungen, Behörden, Verbänden, gewerkschaftlichen Vertretungen, Schulen, Presse) und der Öffentlichkeit. Des Weiteren ist die aktive Einbeziehung des gesamten Personals vorgesehen. Die Umweltschutzklärung ist das endgültige Dokument, in dem die Aspekte zum Umweltschutz und zur Sicherheit am Arbeitsplatz, die Initiativen zum Schutz der Umwelt an diesem Standort sowie die Ziele beschrieben werden, die das Unternehmen im Rahmen des kontinuierlichen Verbesserungsprozesses erreichen will. Die Erklärung wird von einem zugelassenen Umweltgutachter nach vor Ort durchgeführten Inspektionen (Audits) genehmigt, ist verfügbar auf der Website www.ceramichelea.it. Lea Ceramiche, ein Werk was grossen Wert auf Umweltschutz legt, produziert seine Fliesen in allen Werken der Panariagroup, die diese beide Umweltzertifikate ISO 14001 und die EMAS Registrierung erhalten haben, was das große Engagement und die Sensibilität des Unternehmens in bezug auf Ethik, Umweltschutz, Sicherheit und Qualität unter Beweis stellt.



CREDITI LEED V4

Lea Ceramiche è membro del U.S. Green Building Council e del Green Building Council ITALIA, organizzazioni che promuovono la realizzazione di edifici ed opere nel rispetto dell'ambiente, della salute e del benessere delle persone che ci vivono e lavorano

LEED V4 nasce da U.S. Green Building Council per offrire a progettisti, architetti e costruttori uno nuovo strumento per realizzare edifici secondo standard più esigenti in termini di sostenibilità, salubrità e vivibilità.

Anche per i materiali da costruzione, tra cui le piastrelle di ceramica, vengono richiesti requisiti più severi e più completi, tra cui anche la Dichiarazione Ambientale EPD.

Le schede LEED delle serie Lea Ceramiche sono disponibili su richiesta, sia secondo il protocollo LEED V4 che secondo i protocolli del GBC Italia



LEED V4 CREDITS

Lea Ceramiche is a member of the U.S. Green Building Council and of the Green Building Council ITALIA. These organizations promote the construction of buildings and other works which respect the environment as well as the health and well-being of the people who live and work within them.

376/
377

LEED V4 was created by the U.S. Green Building Council to provide designers, architects, and builders with a new tool for the construction of buildings that adhere to more elevated standards of sustainability, health, and liveability.

More stringent and thorough requisites are required of building materials, like ceramic tiles, including the Environmental Product Declaration (EPD).

The LEED data sheets for Lea Ceramiche are available upon request, according to both the LEED V4 and GBC Italia protocols.

CRÉDITS LEED V4

Lea Ceramiche est membre de l'U.S. Green Building Council et du Green Building Council d'Italie. Ces organisations promeuvent la réalisation de bâtiments et de travaux qui respectent l'environnement, la santé et le bien-être des personnes qui travaillent à la réalisation et de celles pour lesquelles elle est destinée.

LEED V4 a été créé par U.S. Green Building Council pour offrir aux designers, architectes et constructeurs, un nouvel outil capable de répondre aux dernières exigences de réalisation en termes de durabilité, salubrité et bien-être.

Pour les matériaux de construction, tels que les carreaux en céramique, les exigences sont encore plus sévères et plus complètes, et doivent être accompagnés notamment d'une Déclaration Environnementale Produit (DEP).

Les fiches LEED des séries Lea Ceramiche sont disponibles sur demande, selon le protocole LEED V4 ainsi que selon les protocoles GBC Italie.

KREDITE LEED V4

Lea Ceramiche ist ein Mitglied des US-Green Building Councils und des Green Building Councils ITALIEN, beides Organisationen, die den Bau von Gebäuden und Strukturen unter Beachtung der Umwelt, Gesundheit und des Wohlbefindens der Menschen, die darin leben und arbeiten fördern.

LEED V4 ist ein Projekt des US-Green Building Councils, um Designern, Architekten und Konstrukteuren ein neues Instrument zu liefern, Gebäude gemäß den anspruchsvollsten Standards in Bezug auf Nachhaltigkeit, Gesundheit und Lebensqualität zu realisieren.

Auch für Baumaterialien, einschließlich keramischer Fliesen, werden strengere und vollständiger Anforderungen, einschließlich der Umwelterklärung EPD verlangt.

Die LEED-Karten der Serie Lea Ceramiche sind auf Anfrage erhältlich, sowohl gemäß dem Protokoll LEED-V4 als auch gemäß den Protokollen des GBC Italien.



EPD - DICHIARAZIONE AMBIENTALE DI PRODOTTO

La Dichiarazione Ambientale di Prodotto (EPD) comunica in modo trasparente le prestazioni ambientali del gres porcellanato Lea Ceramiche basandosi sull'analisi del ciclo di vita (LCA). Si tratta di una EPD media di settore, certificata nell'ottobre 2016 da un Ente indipendente di terza parte secondo regole ufficiali (PCR), richiesta dai principali sistemi di certificazione degli edifici quali **LEED** (internazionale), **BREEAM** (Inghilterra), **HQE** (Francia) e **DGNB** (Germania), nonché in schemi legislativi in **Italia** (requisiti per appalti pubblici sostenibili). E' una certificazione volontaria, che valorizza ancor più i materiali Lea Ceramiche perché prodotti secondo i migliori standard di sostenibilità e responsabilità

EPD – ENVIRONMENTAL PRODUCT DECLARATION

The Environmental Product Declaration (EPD) is a transparency tool that communicates the environmental performances of Lea Ceramiche porcelain tile through a Life Cycle Assessment (LCA). This is a Sector-wide EPD, certified in October 2016 by an independent third party according to official guidelines (PCR), requested by the primary building certification systems such as **LEED** (international), **BREEAM** (England), **HQE** (France), and **DGNB** (Germany), as well as the legislative frameworks in **Italy** (requisites for sustainable public contracts). It is a voluntary certification that gives additional value to Lea Ceramiche products because they are manufactured according to the highest standards of sustainability and responsibility.

DEP - DÉCLARATION ENVIRONNEMENTALE PRODUIT

La Déclaration Environnementale Produit (DEP) communique de manière transparente les performances environnementales du grès cérame Lea Ceramiche en se basant sur l'analyse du cycle de vie (ACV). Il s'agit d'une DEP par secteur, certifiée en octobre 2016 par une Autorité indépendante de tierce partie, selon les normes officielles (Règles des Catégories de Produits) requises par les principaux systèmes de certification des bâtiments tels que **LEED** (pour l'international), **BREEAM** (Angleterre), **HQE** (France) et **DGNB** (Allemagne), et par les cadres législatifs prévus en **Italie** (conditions pour participer aux marchés publics durables). Cette certification est une démarche volontaire, et vise à apporter une valeur supplémentaire aux matériaux Lea Ceramiche, fabriqués de manière responsable et selon les meilleurs standards écologiques.

EPD - / UMWELT-PRODUKTDEKLARATION

Die Umwelt-Produktdeklaration (EPD) teilt in einer transparenten Art und Weise die Umweltleistung von Feinsteinzeug Lea Ceramiche auf der Grundlage der "Lebenszyklusanalyse" (LCA) mit. Es handelt sich um eine branchenweite EPD, zertifiziert im Oktober 2016 durch eine unabhängige dritte Partei nach offiziellen Regeln (PCR), die von den wichtigsten Zertifizierungssystemen für Gebäude, wie **LEED** (International), **BREEAM** (England), **HQE** (Frankreich) und **DGNB** (Deutschland), sowie in Gesetzgebungsregelungen in **Italien** (Anforderungen für nachhaltige öffentliche Beschaffung) verlangt wird. Es ist eine freiwillige Zertifizierung, die die Materialien Lea Ceramiche Produkte weiter aufwertet, da sie nach den höchsten Standards der Nachhaltigkeit und Verantwortung produziert werden.



CERTIFICAZIONE 40% MATERIALE RICICLATO

CERTIFIED 40% RECYCLED MATERIAL

CERTIFIÉ 40% DE MATÉRIEL RECYCLÉ

ZERTIFIZIERUNG 40% RECYCELTES
MATERIAL



CERTIFICATO / CERTIFICATE

N. P1172

SI CERTIFICA CHE I PRODOTTI - WE HEREBY CERTIFY THAT THE PRODUCT

PIASTRELLE DI CERAMICA REALIZZATE CON MATERIALE RICICLATO
CERAMIC TILES PRODUCED WITH RECYCLED MATERIALS
(dettagli negli allegati / details in annexes 1-2-3-4-5-6)

DELL'ORGANIZZAZIONE / OF THE ORGANIZATION

PANARIAGROUP INDUSTRIE CERAMICHE S.p.A.
41034 FINALE EMILIA (MO) - Via Panaria Bassa 22/A

È CONFORME AI COMPLEI WITH

DT 55 ED 01 010409

"DOCUMENTO TECNICO PER LA CERTIFICAZIONE DI PRODOTTO RELATIVA A PRODOTTI
 PER L'EDILIZIA CON PERCENTUALE INDICATA DI MATERIALE RICICLATO:
 PIASTRELLE DI CERAMICA E SEMILAVORATI DA UTILIZZARSI PER LA LORO PRODUZIONE"

"TECHNICAL DOCUMENT FOR PRODUCT CERTIFICATION OF CONSTRUCTION PRODUCTS
 WITH THE SPECIFIED PERCENTAGE OF RECYCLED MATERIAL
 CERAMIC TILES AND SEMI-FINISHED ITEMS FOR THE PRODUCTION THEREOF"

CERTIFICAZIONE "SYSTEM 2" (SISTEMI 2000) GIUGNO 2004

Il presente certificato non è da ritenersi valido se non accompagnato dal relativo allegato
 This certificate is not valid without the Annexes Addendum

IL PRESENTE CERTIFICATO È SOGGETTO AL REPERITO DEL REGOLAMENTO PER LA CERTIFICAZIONE DI CONFORMITÀ DI PRODOTTO
 THIS CERTIFICATE IS SUBJECT TO THE REQUISITES OF THE REGULATIONS AND THE "PRODUCT CERTIFICATION"

PRIMA EMISSIONE: **28/07/2009**
 PRIMA EMISSIONE: **28/07/2009**
 EMISSIONE CORRENTE: **08/07/2016**
 EMISSIONE CORRENTE: **08/07/2016**
 DATA DI SCADENZA: **24/06/2018**
 DATA DI SCADENZA: **24/06/2018**

CERTQUALITY S.p.A.

CERTQUALITY S.p.A. ISTITUTO DI CERTIFICAZIONE DELLA QUALITÀ
 Via G. Cardano, 4 - 20123 Milano - Tel. 02/8699171 Fax. 02/8699170 certqual@certqual.it info@certqual.it www.certqual.it



ALLEGATO 2 AL CERTIFICATO / ENCLOSURE TO CERTIFICATE N. P1172

SERIE DI PRODOTTO PIASTRELLE IN CERAMICA		STABILIMENTO / PRODUCTION SITE	MATERIALE RICICLATO / RECYCLED MATERIAL	
			% PRE-CONSUMO / PRE-CONSUMER	% POST-CONSUMO / POST-CONSUMER
MACROBRAND	SERIE/SERIES			
LEA CERAMICHE	Tecnoquarti	Tronò	0,40%	
	Sonetto	Finale Emilia	0,40%	
	Scandalo	Finale Emilia	0,40%	
	Espresso Stone Project	Tronò	0,40%	
	Univertù	Tronò	0,40%	
	Grande Pietra	Finale Emilia	0,40%	
	System 12	Finale Emilia	0,40%	
	Industrial	Tronò	0,40%	
	Big London	Tronò	0,40%	
	Maki	Tronò	0,40%	
	Canalini	Finale Emilia	0,40%	
	Seppia	Tronò	0,40%	
	Dario	Tronò	0,40%	
	Big Tondal	Tronò	0,40%	
	Isola	Tronò	0,40%	
	Arancia	Tronò	0,40%	
	Mangrovia	Tronò	0,40%	
	Big Park	Tronò	0,40%	
	Orchi	Tronò	0,40%	
	Blau	Finale Emilia	0,40%	
Big Reserve	Tronò	0,40%		
Colonna	Tronò	0,40%		
Outdoor	Finale Emilia	0,40%		

Prodotto presso gli stabilimenti di Finale Emilia e Tronò / Produced in Finale Emilia and Tronò production sites

IL PRESENTE ALLEGATO NON È DA RITENERSI VALIDO SE NON ACCOMPAGNATO DAL RELATIVO CERTIFICATO
 THIS ANNEX IS NOT VALID WITHOUT THE RELATIVE CERTIFICATE

PRIMA EMISSIONE: **28/07/2009**
 PRIMA EMISSIONE: **28/07/2009**
 EMISSIONE CORRENTE: **08/07/2016**
 EMISSIONE CORRENTE: **08/07/2016**
 DATA DI SCADENZA: **24/06/2018**
 DATA DI SCADENZA: **24/06/2018**

CERTQUALITY S.p.A.

CERTQUALITY S.p.A. ISTITUTO DI CERTIFICAZIONE DELLA QUALITÀ
 Via G. Cardano, 4 - 20123 Milano - Tel. 02/8699171 Fax. 02/8699170 certqual@certqual.it info@certqual.it www.certqual.it

LEA CERAMICHE

40%



RECYCLED CERAMIC CONTENT
[PRECONSUMER MATERIALS]
LEED COMPLIANT CREDIT MR

CERTIFICAZIONI DI PRODOTTO

La marcatura CE è la certificazione di sicurezza del prodotto richiesta dall'Unione Europea, ed ha lo scopo di salvaguardare la salute delle persone e i beni nelle opere di costruzione. Il nuovo Regolamento UE N. 305/2011 entra in vigore il 1 luglio 2013. La novità più rilevante è l'introduzione della Dichiarazione di Prestazione (DOP, Declaration Of Performance) con la quale il fabbricante comunica i requisiti di sicurezza dei propri materiali. Le lastre in gres porcellanato Slimtech 3plus - Slimtech 5plus sono in possesso del marchio CE (cfr. DOP004LEA - cfr. DOP005LEA). L'applicazione sul retro di una rete in fibra di vetro conferisce a questi prodotti le classi di reazione al fuoco indicate nelle tabelle tecniche Slimtech.

Le DOP di Lea Ceramiche sono disponibili sul sito internet www.ceramichelea.com.

PRODUCT CERTIFICATION

The CE mark is the safety product certification required by EU and it is finalized to preserve the people's health and the goods in buildings.

The new Regulation UE N. 305/2011 is valid from the first of July 2013. The most important news is the introduction of the Declaration Of Performance (DOP) with which the supplier communicates the safety requirements concerning own materials.

Slimtech 3plus - Slimtech 5plus porcelain stoneware slabs have the CE mark (cf. DOP004PAN - cf. DOP005PAN). The application of a fibreglass mesh on the back confer to these products the categories of fire resistance indicated in the Slimtech technical tables.

Lea Ceramiche DOP are available on the website www.ceramichelea.com.

CERTIFICATIONS DE PRODUIT

La marque CE est la certification de sécurité des produits demandé par l'Union Européenne ayant comme objectif la protection et la santé des personnes et des biens dans les ouvrages du bâtiments.

Le nouveau Règlement UE Nr. 305/2011 entre en vigueur le 1er Juillet 2013. La nouveauté la plus importante est l'introduction de la Déclaration de Prestation (DOP, Declaration Of Performance) par la quelle le fabricant communique les caractéristiques de sécurité de ses produits.

Les dalles en grès cérame Slimtech 3plus - Slimtech 5plus possèdent le marquage CE (cfr. DOP004LEA - cfr. DOP005LEA). L'application d'une couche en fibre de verre au dos de chaque dalle confère aux produits une haute résistance au feu. La classe de résistance des dalles est disponible dans les tableaux techniques Slimtech.

Les DOP de Lea Ceramiche sont disponibles sur le site internet www.ceramichelea.com.

BESCHEINIGUNG DES PRODUKTS

Das CE- Kennzeichnung ist die von EU angefragte Zertifizierung für die Produkt- Sicherheit, und hat das Zweck die Gesundheit der Menschen zu schützen und die Güter in der Bauphase zu bewahren.

Die neue Regelung UE N. 305/2011 tritt am 1.07.2013 in Kraft. Die wichtigste Neuheit ist die Einfügung der Leistungserklärung (DOP, Declaration Of Performance), mit der der Hersteller die Sicherheitsanforderungen eigenen Materialien mitteilt.

Die Feinsteinzeugfliesen Slimtech 3plus - Slimtech 5plus sind mit dem CE-Markenzeichen versehen (siehe DOP004LEA - siehe DOP005LEA). Die Anwendung eines Glasfasernetzes auf der Rückseite der Fliesen verleiht diesen Produkten die in den technischen Tabellen Slimtech aufgeführten Brandklassen.

Die DOP Lea Ceramiche sind auf Internet Site www.ceramichelea.com verfügbar.



LEA CERAMICHE

DOP001LEA DOP002LEA DOP003LEA DOP004LEA DOP005LEA
05
LEA CERAMICHE Via Cameazzo n° 21 - 41042 Fiorano Modenese (MO) - Italy Panariagroup Industrie Ceramiche SpA
EN 14411:2016
Lea Ceramiche Porcelain Tiles: Dry-pressed ceramic tiles with low water absorption $E_b \leq 0,5\%$ for flooring and wall finishes, internal and external applications (DOP001LEA).
Lea Ceramiche Wall Tiles: Dry-pressed ceramic tiles with water absorption level $E_b > 10\%$ for internal wall applications (DOP002LEA).
Slimtech 3mm: Dry pressed ceramic tiles with low water absorption $E_b \leq 0,5\%$ for internal and external wall applications (DOP003LEA).
Slimtech 3Plus: Dry pressed ceramic tiles with low water absorption $E_b \leq 0,5\%$ for internal flooring and internal and external wall applications (DOP004LEA).
Slimtech 5Plus: Dry pressed ceramic tiles with low water absorption $E_b \leq 0,5\%$ for internal flooring and internal and external wall applications (DOP005LEA).

CERTIFICAZIONI DI PRODOTTO

Concessione PT0061 / Concessione PT0128.
Gruppo di prodotto Bla UGL.

Concessione PT0038.
Gruppo di prodotto Bla GL.

**marchio certiquality-uni / key mark:
garanzia di qualità per il consumatore.**

Dal 1998 Lea Ceramiche ha richiesto ed ottenuto la certificazione UNI, marchio rilasciato dall'Ente Nazionale di Certificazione (membro CEN Comitato Europeo di Normazione).

Dal 2006 Lea Ceramiche ha anche richiesto ed ottenuto il Marchio di Qualità Europeo di prodotto KEY-MARK rilasciato dal CEN.

Il marchio KEY-MARK ed il marchio Certiquality-UNI attestano che i prodotti certificati sono conformi alle normative europee per le piastrelle ceramiche.

PRODUCT CERTIFICATION

certiquality uni-mark / key mark: a guarantee of quality for the consumer.

Lea Ceramiche applied for and obtained UNI approval, a stamp issued by the National Standards Body (member of CEN, European Committee for Standardization) since 1998. Lea Ceramiche applied for and obtained also KEY-MARK, Mark of Quality European of product approval of CEN since 2006. The KEY-MARK and the Certiquality-UNI mark verifies that the approved products conform with European regulations for ceramic tiles.

CERTIFICATIONS DE PRODUIT

le label certiquality-uni / key mark: garantie de qualité pour le consommateur.

A partir de 1998, l'entreprise Lea Ceramiche a demandé et obtenu la certification UNI, label délivré par l'Autorité Nationale de Certification (membre CEN Comité Européen de Normalisation). A partir de 2006, l'entreprise Lea Ceramiche a demandé et obtenu aussi la certification le KEY-MARK, Label de Qualité Européenne de produit délivré par le CEN. Le Label KEY-MARK et le Label Certiquality-UNI attestent que les produits certifiés sont conformes aux normes européennes pour les carreaux céramiques.

BESCHEINIGUNG DES PRODUKTS

certiquality uni-zertifizierung / key mark: qualitätsgarantie für den verbrucher.

Seit 1998 besitzt das Unternehmen Lea Ceramiche die UNI-Zertifizierung, die vom italienischen Institut für Normung, Ente Nazionale Italiano di Certificazione, (Mitglied des Europäischen Komitees für Normung CEN) ausgestellt wird. Seit 2006 besitzt das Unternehmen Lea Ceramiche die KEY-MARK-Zertifizierung, Europäischen Qualitätsmark den Produkte. Die Kennzeichnung KEY-MARK und die Kennzeichnung Certiquality-UNI bescheinigt, dass die zertifizierten Produkte den Europäischen Richtlinien für Keramikfliesen entsprechen.



023

CERTIFICAZIONI DI PRODOTTO

classement nf-upec

È una certificazione di prodotto, rilasciata dall'istituto francese CSTB, che verifica l'idoneità tecnica dei prodotti di prima scelta in relazione al tipo di destinazione d'uso.

PRODUCT CERTIFICATION

This is a product approval certificate, issued by the French institute CSTB, who verifies the technical suitability of top quality products in relation to the type of use intended.

CERTIFICATIONS DE PRODUIT

Il s'agit d'une certification de produit, délivrée par l'Établissement français CSTB, qui vérifie la conformité technique des produits de premier choix par rapport à la destination d'usage.

BESCHEINIGUNG DES PRODUKTS

Es handelt sich um eine Produktzertifizierung, die vom französischen Institut CSTB ausgestellt wird. Die Behörde prüft die technische Eignung von Erzeugnissen erster Wahl im Verhältnis zu ihrem Verwendungszweck.



PRODOTTI CERTIFICATI

384/385

CERTIFIED PRODUCTS

PRODUITS CERTIFIÉS

ZERTIFIZIERTE ERZEUGNISSE

serie series series serien	spessore thickness starke epaisseur	formato (cm) sizes (cm) formate (cm) formats (cm)	colori colors couleurs farben	classement upec	marchio certiquality-uni key mark n°concessione
basaltina stone project	11 mm	30x60	lappata	U3P3E3C2	PT 0061
			naturale - sabbiata - scalpellata - stuccata - texture	U4P3E3C2	
	60x60	lappata	U3P3E3C2		
		naturale - sabbiata - scalpellata - stuccata - texture	U4P3E3C2		
	12 mm	60x120	lappata	U3P3E3C2	
naturale - sabbiata - stuccata	U4P3E3C2				
bio plank	11 mm	20x120	oak noisette - oak ice		PT 0061
bio recover	12 mm	20x180	warm cream - golden flame - old walnut		PT 061
	10,5 mm	20x121,5	warm cream - golden flame - old walnut		
cliffstone	11 mm	90x90	white dover - beige madeira - taupe moher grey tenerife		PT 0061
			60x120 60x90 60x60 40x60 30x60 20x60	white dover - beige madeira - taupe moher grey tenerife	
	10 mm	60x60 30x60	calacatta shine - cristal white - romance safari passion pulpis - bianco statuario - gray stone		
			calacatta shine lux - cristal white lux romance safari lux - passion pulpis lux bianco statuario lux - gray stone lux		
dreaming	11 mm	75x75	calacatta shine - cristal white - romance safari passion pulpis - bianco statuario - gray stone		PT 0038
	10 mm	60x60 30x60	calacatta shine lux - cristal white lux romance safari lux - passion pulpis lux bianco statuario lux - gray stone lux		
			calacatta shine lux - cristal white lux romance safari lux - passion pulpis lux bianco statuario lux - gray stone lux		
	11 mm	73x73	calacatta shine lux - cristal white lux romance safari lux - passion pulpis lux bianco statuario lux - gray stone lux		
metropolis	10 mm	30x60	berlin night - london gray - milano ecru new york coal - paris amande - rio coffee shanghai iron - tokyo white	U4P3E3C2	PT 0061
		60x60	berlin night texture - milano ecru texture rio coffee texture - shanghai iron texture tokyo white texture	U4P4E3C2	
	11 mm	45x90 90x90	berlin night texture - milano ecru texture rio coffee texture - shanghai iron texture tokyo white texture	U4P3E3C2	
outdoor	9 mm	20x20		U4P4+E3C2	
		20x30,2	dorato - grigio	U4P4E3C2	
		20x40,4		U4P3E3C2	
salento	11 mm	37,5x75	beige ostuni - bianco leuca	U4P4E3C2	
	11 mm	75x75	beige ostuni - bianco leuca	U4P3E3C2	
stoneclay	9 mm	45,2x45,2		U4P4E3C2	PT 0128
		30x60	endre - charcoal - lime - silt	U4P4E3C2	
	10 mm	60x60		U4P4+E3C2	
		60,4x60,4			
sunrise	10 mm	20x90,5	american walnut - australian gold - african amber asian grey - european dark		PT 0128
tecn quartz	12 mm	20x30	doral - silver - gneiss	U4P4+E3C2	PT 0061 (60x60) PT 0061 (30x60)
	12 mm	20x60 40x60 60x60	doral - silver - gneiss	U4P3E3C2	
			doral - silver - gneiss - hard black	U4P4+E3C2	
	12 mm	20x30 20x60	hard black	U4P4E3C2	
	12 mm	60x60	hard black	U4P4+E3C2	

CARATTERISTICHE TECNICHE: GRES PORCELLANATO

TECHNICAL FEATURES PORCELAIN TILES

CARACTÉRISTIQUES TECHNIQUES DU GRÉS CÉRAME

TECHNISCHE EIGENSCHAFTEN DES GRES FEINSTEINZEUGS

CONFORME - ACCORDING TO - CONFORME - GEMÄß: ISO 13006 G - EN 14411 G

	CARATTERISTICHE TECNICHE TECHNICAL FEATURES CARACTÉRISTIQUES TECHNIQUES TECHNISCHE EIGENSCHAFTEN	metodo di prova test method méthode d'essai prüfmethode										
	assorbimento d'acqua water absorption absorption d'eau wasserabsorption	ISO 10545-3										
	resistenza alla flessione modulus of rupture résistance à la flexion beigefestigkeit	ISO 10545-4										
	sforzo di rottura (S) breaking strength (S) chargement de rupture (S) bruchlast (S)	ISO 10545-4										
	resistenza all'abrasione profonda résistance to deep abrasion résistance à l'abrasion profonde widerstand gegen tiefenabrieb	ISO 10545-6										
	dilatazione termica lineare linear thermal expansion dilatation thermique linéaire thermische dilatation	ISO 10545-8										
	resistenza agli sbalzi termici thermal shock resistance résistance aux chocs thermiques temperaturwechselbeständigkeit	ISO 10545-9										
	resistenza al cavillo crazing resistance résistance au tressilage haarißbeständigkeit	ISO 10545-11										
	resistenza al gelo frost resistance résistance au gel frostbeständigkeit	ISO 10545-12										
	resistenza attacco chimico* chemical resistance résistance chimique chemische beständigkeit	ISO 10545-13										
	resistenza chimica a prodotti di uso domestico house hold chemicals resistance résistance aux agents chimique des produits pour emploi domestique chemische beständigkeit gegen haushalt putzmittel	ISO 10545-13										
	resistenza alle macchie stain resistance résistance aux taches fleckenbeständigkeit	ISO 10545-14										
	caratteristiche dimensionali dimensions caracteristiques dimensionnelles sctenmasse	<table border="1"> <tr> <td>lunghezza e larghezza length and width longueur et largeur länge und breite</td> <td>ISO 10545-2</td> </tr> <tr> <td>rette linearità spigoli straightness of sides rectitude des arêtes kantengeradheit</td> <td>ISO 10545-2</td> </tr> <tr> <td>ortogonalità rectangularity orthogonalité rechtwinkligkeit</td> <td>ISO 10545-2</td> </tr> <tr> <td>planarità warpage planéité ebenflächigkeit</td> <td>ISO 10545-2</td> </tr> <tr> <td>spessore thickness épaisseur stärke</td> <td>ISO 10545-2</td> </tr> </table>	lunghezza e larghezza length and width longueur et largeur länge und breite	ISO 10545-2	rette linearità spigoli straightness of sides rectitude des arêtes kantengeradheit	ISO 10545-2	ortogonalità rectangularity orthogonalité rechtwinkligkeit	ISO 10545-2	planarità warpage planéité ebenflächigkeit	ISO 10545-2	spessore thickness épaisseur stärke	ISO 10545-2
lunghezza e larghezza length and width longueur et largeur länge und breite	ISO 10545-2											
rette linearità spigoli straightness of sides rectitude des arêtes kantengeradheit	ISO 10545-2											
ortogonalità rectangularity orthogonalité rechtwinkligkeit	ISO 10545-2											
planarità warpage planéité ebenflächigkeit	ISO 10545-2											
spessore thickness épaisseur stärke	ISO 10545-2											











*ad esclusione dell'acido fluoridrico e suoi derivati
excluding hydrofluoridric acid and its derivatives
sauf l'acide fluorhydrique et ses dérivés
ausgenommen den fluorwasserstoff und seine
derivate

	LEA	LEA	LEA
requisiti prescritti required values valuer requise vorgeschriebener wert ISO 13006 - G / EN 14411 - G gruppo / group Bla	valori medi average values valeurs moyens durchschnittliche werte UGL: non smaltato UGL: unglazed	valori medi average values valeurs moyens durchschnittliche werte GL: smaltato - levigato GL: glazed - polished	valori medi average values valeurs moyens durchschnittliche werte UGL: levigato - lappato UGL: polished - lappato
≤ 0,5%	0,05%	0,05%	0,05%
≥ 35 N/mm ²	50 N/mm ²	50 N/mm ²	50 N/mm ²
≥ 1300 N	conforme compliant conforme gemäß	conforme compliant conforme gemäß	conforme compliant conforme gemäß
≤ 175 mm ³	145 mm ³	non applicabile not applicable no aplicable nicht anwendbar	145 mm ³
requisito non previsto no provision non prévu nicht erforderlich	$\alpha \leq 7 \times 10^{-6} \text{ } ^\circ\text{C}^{-1}$	$\alpha \leq 7 \times 10^{-6} \text{ } ^\circ\text{C}^{-1}$	$\alpha \leq 7 \times 10^{-6} \text{ } ^\circ\text{C}^{-1}$
nessuna alterazione no alterations aucune altération keine änderung	resistente resistant résistant beständig	resistente resistant résistant beständig	resistente resistant résistant beständig
nessuna alterazione no alterations aucune altération keine änderung	non applicabile not applicable no aplicable nicht anwendbar	resistente resistant résistant beständig	non applicabile not applicable no aplicable nicht anwendbar
nessuna alterazione no alterations aucune altération keine änderung	resistente resistant résistant beständig	resistente resistant résistant beständig	resistente resistant résistant beständig
come indicato dal produttore as indicated by manufacturer comme indiqué par le producteur wie vom hersteller angegeben	ULA - UHA (resistente) (resistant) (résistant) (beständig)	GLA - GHA (resistente) (resistant) (résistant) (beständig)	ULA - UHA (resistente) (resistant) (résistant) (beständig)
UB / GB min.	UA (resistente) (resistant) (résistant) (beständig)	GA (resistente) (resistant) (résistant) (beständig)	UA (resistente) (resistant) (résistant) (beständig)
classe 3 min.	5 (resistente) (resistant) (résistant) (beständig)	5 (resistente) (resistant) (résistant) (beständig) ≥ 3 (lux)	5 (resistente) (resistant) (résistant) (beständig) ≥ 3 (lux)
± 0,6%	conforme compliant conforme gemäß	conforme compliant conforme gemäß	conforme compliant conforme gemäß
± 0,5%	conforme compliant conforme gemäß	conforme compliant conforme gemäß	conforme compliant conforme gemäß
± 0,6%	conforme compliant conforme gemäß	conforme compliant conforme gemäß	conforme compliant conforme gemäß
± 0,5%	conforme compliant conforme gemäß	conforme compliant conforme gemäß	conforme compliant conforme gemäß
± 5%	conforme compliant conforme gemäß	conforme compliant conforme gemäß	conforme compliant conforme gemäß

TECHNICAL CHARACTERISTICS: PORCELAIN TILES

(AMERICAN STANDARDS)

ACCORDING TO ANSI A 137.1 GLAZED AND UNGLAZED PORCELAIN TILES (CLASS P1)

TECHNICAL FEATURES	test method	
 water absorption	ASTM C373	
 breaking strength	ASTM C648	
 deep abrasion resistance	ASTM C1243	
 linear thermal expansion	ASTM C372	
 thermal shock resistance	ASTM C484	
 crazing resistance	ASTM C424	
 chemical resistance*	ASTM C650	
 frost resistance	ASTM C1026	
 bond resistance	ASTM C482	
 stain resistance	ASTM C1378	
 dimensions	edge warpage	ASTM C485
	diagonal warpage	ASTM C485
	nominal dimensions	ASTM C499
	calber range	ASTM C499
	thickness	ASTM C499
	wedging	ASTM C502

*excluding hydrofluoridric acid and its derivatives

	LEA		LEA	LEA
required values	average values		average values	average values
ANSI A 137.1	UGL: unglazed		GL: glazed - polished	UGL: polished - lappato
≤ 0.5%	0.05%		0.05%	0.05%
≥ 250 lbf	compliant		compliant	compliant
≤ 175 mm ³	145 mm ³		not applicable	145 mm ³
no provision	$\alpha \leq 8 \times 10^{-6} \text{ } ^\circ\text{C}^{-1}$ $\alpha \leq 4.4 \times 10^{-6} \text{ } ^\circ\text{F}^{-1}$		$\alpha \leq 8 \times 10^{-6} \text{ } ^\circ\text{C}^{-1}$ $\alpha \leq 4.4 \times 10^{-6} \text{ } ^\circ\text{F}^{-1}$	$\alpha \leq 8 \times 10^{-6} \text{ } ^\circ\text{C}^{-1}$ $\alpha \leq 4.4 \times 10^{-6} \text{ } ^\circ\text{F}^{-1}$
no alterations	resistant		resistant	resistant
no alterations	not applicable		resistant	not applicable
as indicated by manufacturer	A resistant		A resistant	A resistant
as indicated by manufacturer	resistant		resistant	resistant
≥ 50 PSI	compliant		compliant	compliant
as indicated by manufacturer	A resistant		A resistant C (lux)	A resistant
rectified ± 0.40% or max ± 0.05 inch for tiles up to 24"x24" or max ± 0.07 inch for tiles larger than 24"x24"	calibrated ± 0.75% or max ± 0.09 inch	compliant	compliant	compliant
rectified ± 0.40% or max ± 0.07 inch	calibrated ± 0.50% or max ± 0.08 inch	compliant	compliant	compliant
rectified - 3.0% / + 2.0% of nominal dimensions	calibrated ± 3.0% of nominal dimensions	± 1.5%	± 1.5%	± 1.5%
rectified ± 0.25% or max ± 0.03 inch	calibrated ± 0.50% or max ± 0.08 inch	compliant	compliant	compliant
≤ 0.040 inch	≤ 0.040 inch	≤ 0.030 inch	≤ 0.030 inch	≤ 0.030 inch
rectified ± 0.25% or max ± 0.03 inch	calibrated ± 0.50% or max + 0.08 inch	compliant	compliant	compliant

CARATTERISTICHE TECNICHE: MONOPOROSA IN PASTA BIANCA SMALTATA

TECHNICAL FEATURES
OF GLAZED WHITE BODY POROUS
SINGLE-FIRED TILES

CARACTÉRISTIQUES TECHNIQUES
REVÊTEMENT MONOCUISSONS
EN PÂTE BLANCHE ÉMAILLÉ

TECHNISCHE EIGENSCHAFTEN
WANDFLIESEN AUS WEISSCHERBIGEN
GLASIERTE MONOPOROSA

CONFORME - ACCORDING TO - CONFORME - GEMÄß:
ISO 13006 L - EN 14411 L

CARATTERISTICHE TECNICHE
TECHNICAL FEATURES
CARACTÉRISTIQUES TECHNIQUES
TECHNISCHE EIGENSCHAFTEN



assorbimento d'acqua

water absorption
absorption d'eau
wasserabsorption



resistenza alla flessione

modulus of rupture
résistance à la flexion
beigefestigkeit



sforzò di rottura (S)

breaking strength (S)
chargement de rupture (S)
bruchlast (S)



dilatazione termica lineare

linear thermal expansion
dilation thermique linéaire
thermische dilatation



resistenza agli sbalzi termici

thermal shock resistance
résistance aux chocs thermiques
temperaturwechselbeständigkeit



resistenza al cavillo

crazing resistance
résistance au tressillage
haarißbeständigkeit



resistenza al gelo

frost resistance
résistance au gel
frostbeständigkeit



resistenza attacco chimico*

chemical resistance
résistance chimique
chemischee beständigkeit



resistenza chimica a prodotti di uso domestico

house hold chemicals resistance
résistance aux agents chimique des produits
pour emploi domestique
chemische beständigkeit gegen haushalt putzmittel



resistenza alle macchie

stain resistance
résistance aux taches
fleckenbeständigkeit



caratteristiche dimensionali

dimensions
caracteristiques dimensionnelles
scitenmasse

* ad esclusione dell'acido fluoridrico e suoi derivati
excluding hydrofluoridric acid and its derivatives
sauf l'acide fluorhydrique et ses dérivés
ausgenommen den fluorwasserstoff und seine derivate

LEA

metodo di prova test method méthode d'essai prüfmethode		requisiti prescritti required values valeur requise vorgeschriebener wert ISO 13006 - L / EN 14411 - L gruppo / group BIII GL	valori medi average values valeurs moyens durchschnittliche werte GL: smaltato GL: glazed
ISO 10545-3		> 10%	> 10%
ISO 10545-4		≥ 12 N/mm ²	18 N/mm ²
ISO 10545-4		≥ 600 N	≥ 600 N
ISO 10545-8		requisito non previsto no provision non prévu nicht erforderlich	$\alpha \leq 7 \times 10^{-6} \text{ } ^\circ\text{C}^{-1}$
ISO 10545-9		nessuna alterazione no alterations aucune altération keine änderung	resistente resistant résistant beständig
ISO 10545-11		nessuna alterazione no alterations aucune altération keine änderung	resistente resistant résistant beständig
ISO 10545-12		come indicato dal produttore as indicated by manufacturer comme indiqué par le producteur wie vom hersteller angegeben	non resistente not resistant ne résiste pas nicht beständig
ISO 10545-13		come indicato dal produttore as indicated by manufacturer comme indiqué par le producteur wie vom hersteller angegeben	GLA - GHA (resistente) (resistant) (résistant) (beständig)
ISO 10545-13		GB min.	GA (resistente) (resistant) (résistant) (beständig) (resistente)
ISO 10545-14		classe 3 min.	5 (resistente) (resistant) (résistant) (beständig)
lunghezza e larghezza length and width longueur et largeur länge und breite	ISO 10545-2	± 0,5%	conforme compliant conforme gemäß
retteilinearità spigoli straightness of sides rectitude des arêtes kantengeradheit	ISO 10545-2	± 0,3%	conforme compliant conforme gemäß
ortogonalità rectangularity orthogonalité rechtwinkligkeit	ISO 10545-2	± 0,5%	conforme compliant conforme gemäß
planarità warpage planéité ebenflächigkeit	ISO 10545-2	curvatura del centro + 0,5% / - 0,3% curvatura del lato + 0,5% / - 0,3% svergolamento ± 0,5%	conforme compliant conforme gemäß
spessore thickness épaisseur stärke	ISO 10545-2	± 10%	conforme compliant conforme gemäß

TECHNICAL FEATURES: GLAZED WHITE BODY POROUS SINGLE-FIRED TILES

(AMERICAN STANDARDS)

ACCORDING TO ANSI A 137.1
GLAZED WALL TILES (CLASS P4)

TECHNICAL FEATURES



water absorption



breaking strength



linear thermal expansion



thermal shock resistance



crazing resistance



chemical resistance*



frost resistance



bond resistance



stain resistance



dimensions

*excluding hydrofluoric acid and its derivatives

LEA

test method	required values	average values	
	ANSI A137.1	GL: glazed	
ASTM C373	7% < E ≤ 20%	compliant	
ASTM C648	≥ 125 lbf	≥ 125 lbf	
ASTM C372	not required	$\alpha \leq 8 \times 10^{-6} \text{ } ^\circ\text{C}^{-1}$ $\alpha \leq 4.4 \times 10^{-6} \text{ } ^\circ\text{F}^{-1}$	
ASTM C484	no alterations	resistant	
ASTM C424	no alterations	resistant	
ASTM C650	as indicated by manufacturer	A resistant	
ASTM C1026	as indicated by manufacturer	not resistant	
ASTM C482	≥ 50 PSI	compliant	
ASTM C1378	as indicated by manufacturer	A resistant	
edge warpage	ASTM C485 rectified - 0.30% / + 0.40% or max - 0.04 inch / + 0.05 inch	calibrated - 0.30% / + 0.40% or max - 0.04 inch / + 0.05 inch	compliant
diagonal warpage	ASTM C485 rectified - 0.30% / + 0.40% or max - 0.05 inch / + 0.07 inch	calibrated - 0.30% / + 0.40% or max - 0.05 inch / + 0.07 inch	compliant
nominal dimensions	ASTM C499 rectified ± 2.0% of nominal dimensions	calibrated ± 2.0% of nominal dimensions	± 1.0%
calber range	ASTM C499 rectified ± 0.25% or max ± 0.03 inch	calibrated ± 0.30% or max ± 0.04 inch	compliant
thickness	ASTM C499 ≤ 0.031 inch	≤ 0.031 inch	compliant
wedging	ASTM C502 rectified ± 0.25% or max ± 0.03 inch	calibrated ± 0.40% or max ± 0.05 inch	compliant











CARATTERISTICHE TECNICHE: GRES LAMINATO

TECHNICAL FEATURES LAMINATED
PORCELAIN

CARACTÉRISTIQUES TECHNIQUES
DU GRÈS LAMINÉ

TECHNISCHE EIGENSCHAFTEN
DES LAMINIERTEN FEINSTEINZEUGS

CONFORME - ACCORDING TO - CONFORME - GEMÄß: ISO 13006 G - EN 14411 G

	CARATTERISTICHE TECNICHE TECHNICAL FEATURES CARACTÉRISTIQUES TECHNIQUES TECHNISCHE EIGENSCHAFTEN	metodo di prova test method méthode d'essai prüfmethode
	assorbimento d'acqua water absorption absorption d'eau wasserabsorption	ISO 10545-3
	resistenza alla flessione modulus of rupture résistance à la flexion beigefestigkeit	ISO 10545-4
	sforzo di rottura (S) breaking strength (S) changement de rupture (S) bruchlast (S)	ISO 10545-4
	resistenza all'abrasione profonda résistance to deep abrasion résistance à l'abrasion profonde widerstand gegen tiefenabrieb	ISO 10545-6
	dilatazione termica lineare linear thermal expansion dilatation thermique linéaire thermische dilatation	ISO 10545-8
	resistenza agli sbalzi termici thermal shock resistance résistance aux chocs thermiques temperaturwechselbeständigkeit	ISO 10545-9
	resistenza al gelo frost resistance résistance au gel frostbeständigkeit	ISO 10545-12
	resistenza attacco chimico** chemical resistance résistance chimique chemische beständigkeit	ISO 10545-13
	resistenza alle macchie stain resistance résistance aux taches fleckenbeständigkeit	ISO 10545-14
	caratteristiche dimensionali dimensions caracteristiques dimensionnelles scitenmasse	<p>lunghezza e larghezza length and width longueur et largeur länge und breite</p> <p>retteilinearità spigoli straightness of sides rectitude des arêtes kantengeradheit</p> <p>ortogonalità rectangularity orthogonalité rechtwinkligkeit</p> <p>planarità warpage planéité ebenflächigkeit</p> <p>spessore thickness épaisseur stärke</p>

* **valore riferito al solo materiale ceramico**
value referred to ceramic material only
valeur qui se réfère uniquement au matériel
céramique
der wert bezieht sich ausschließlich auf
keramisches material

****ad esclusione dell'acido fluoridrico e suoi
derivati**
excluding hydrofluoric acid and its derivatives
sauf l'acide fluorhydrique et ses dérivés
ausgenommen den fluorwasserstoff und seine
derivate

	LEA	LEA	LEA
requisiti prescritti required values valeur requise vorgeschriebener wert ISO 13006 - G / EN 14411 - G Bla UGL	valori medi average values valeurs moyens durchschnittliche werte slimtech 3mm	valori medi average values valeurs moyens durchschnittliche werte slimtech 3plus (lastra + fibra di vetro) (slab + fiberglass)	valori medi average values valeurs moyens durchschnittliche werte slimtech 5plus (lastra + fiba di vetro) (slab + fiberglass)
≤ 0,5%	0,1%	0,1%*	0,1%*
≥ 35 N/mm ²	50 N/mm ²	50 N/mm ²	50 N/mm ²
≥ 700 N	non richiesto. materiale da rivestimento not required. wall covering requise pas prévue. matériel pour mur nicht verlangt. verkleidungsmaterial	conforme compliant conforme gemäß	conforme compliant conforme gemäß
≤ 175 mm ³	conforme compliant conforme gemäß	conforme compliant conforme gemäß	conforme compliant conforme gemäß
requisito non previsto no provision non prévu nicht erforderlich	$\alpha \leq 7 \times 10^{-6} \text{ } ^\circ\text{C}^{-1}$	$\alpha \leq 7 \times 10^{-6} \text{ } ^\circ\text{C}^{-1}$	$\alpha \leq 7 \times 10^{-6} \text{ } ^\circ\text{C}^{-1}$
nessuna alterazione no alterations aucune altération keine änderung	resistente resistant résistant beständig	resistente resistant résistant beständig	resistente resistant résistant beständig
nessuna alterazione no alterations aucune altération keine änderung	resistente resistant résistant beständig	resistente resistant résistant beständig	resistente resistant résistant beständig
come indicato dal produttore as indicated by manufacturer comme indiqué par le producteur wie vom hersteller angegeben	ULA - UHA (resistente) (resistant) (résistant) (beständig)	ULA - UHA (resistente) (resistant) (résistant) (beständig)	ULA - UHA (resistente) (resistant) (résistant) (beständig) ULB - UHB (lev)
classe 3 min.	5 (resistente) (resistant) (résistant) (beständig)	5 (resistente) (resistant) (résistant) (beständig)	5 (resistente) (resistant) (résistant) (beständig) C (lev)
± 0,6%	conforme compliant conforme gemäß	conforme compliant conforme gemäß	conforme compliant conforme gemäß
± 0,5%	conforme compliant conforme gemäß	conforme compliant conforme gemäß	conforme compliant conforme gemäß
± 0,6%	conforme compliant conforme gemäß	conforme compliant conforme gemäß	conforme compliant conforme gemäß
± 0,5%	conforme compliant conforme gemäß	conforme compliant conforme gemäß	conforme compliant conforme gemäß
± 5%	conforme compliant conforme gemäß	conforme compliant conforme gemäß	conforme compliant conforme gemäß

CARATTERISTICHE TECNICHE: GRES LAMINATO

TECHNICAL FEATURES LAMINATED
PORCELAIN

CARACTÉRISTIQUES TECHNIQUES
DU GRÈS LAMINÉ

TECHNISCHE EIGENSCHAFTEN
DES LAMINIERTEN FEINSTEINZEUGS

CARATTERISTICHE TECNICHE
TECHNICAL FEATURES
CARACTÉRISTIQUES TECHNIQUES
TECHNISCHE EIGENSCHAFTEN

metodo di prova
test method
méthode d'essai
prüfmethode

caratteristiche di resistenza allo scivolamento

slip resistance features / caractéristiques de résistance au glissement / eigenschaften rutschfestigkeit



coefficiente di attrito dinamico

dynamic coefficient of friction
frottement dynamique
dynamische reibung

B.C.R. tortus



resistenza allo scivolamento

slip resistance
résistance au glissement
rutschfestigkeit

DIN 51130

caratteristiche termiche

thermal features / caractéristiques thermiques / wärmeeigenschaften



conducibilità termica

heat conducting ability
conductibilité thermique
wärmeleitfähigkeit

EN 12524

reazione al fuoco

fire reaction / réaction au feu / feuerreaktion



reazione al fuoco

fire resistance
caractéristique de résistance au feu
eigenschaften der feuerbeständigkeit

EN 13823
EN 9239-1



reazione al fuoco

fire resistance
caractéristique de résistance au feu
eigenschaften der feuerbeständigkeit

EN 13823
EN 9239-1

flame spread













flame spread



ASTM E84

	LEA	LEA	LEA
riferimenti per la classificazione references for the classification références pour la classification hinweise für die einstufigung	valori medi average values valeurs moyens durchschnittliche werte slimtech 3mm	valori medi average values valeurs moyens durchschnittliche werte slimtech 3plus	valori medi average values valeurs moyens durchschnittliche werte slimtech 5plus
>0,40 L. 13/89 - DM. 236/89 D. Lgs. 503/96 cuoio - asciutto / gomma - bagnato	non richiesto. materiale da rivestimento not required. wall covering equise pas prévue. matériel pour mur nicht verlangt. verkleidungsmaterial	>0,40 (gouache-10 - shade basaltina stone project)	>0,40 (wood-stock)
r9 $6^\circ \leq \alpha \leq 10^\circ$ r10 $10^\circ < \alpha \leq 19^\circ$	non richiesto. materiale da rivestimento not required. wall covering equise pas prévue. matériel pour mur nicht verlangt. verkleidungsmaterial	r9 (gouache-10 - shade basaltina stone project)	r10 (wood-stock)
-	$\lambda = 1,3 \text{ W/m}^\circ\text{K}$ $\lambda = 0.7 \text{ Btu/fth}^\circ\text{F}$	$\lambda = 1,3 \text{ W/m}^\circ\text{K}$ $\lambda = 0.7 \text{ Btu/fth}^\circ\text{F}$	$\lambda = 1,3 \text{ W/m}^\circ\text{K}$ $\lambda = 0.7 \text{ Btu/fth}^\circ\text{F}$
CPR (UE) 305/2011, 2000/147/CE, UNI EN 13501-1	classe A1 FL posa a pavimento floor installation bodeninstallation pose au sol	classe A2 FL - s1 posa a pavimento floor installation bodeninstallation pose au sol	classe A2 FL - s1 posa a pavimento floor installation bodeninstallation pose au sol
CPR (UE) 305/2011, 2000/147/CE, UNI EN 13501-1	classe A1 posa a parete wall installation wandinstallation pose au mur	classe A2 - s1, d0 posa a parete wall installation wandinstallation pose au mur	classe A2 - s1,d0 posa a parete wall installation wandinstallation pose au mur
-	class A	class A	class A

TECHNICAL FEATURES: LAMINATED PORCELAIN

(AMERICAN STANDARDS)

ACCORDING TO ANSI A 137.1 UNGLAZED PORCELAIN TILES (CLASS P1)			
TECHNICAL FEATURES		test method	
	water absorption	ASTM C373	
	modulus of rupture	ASTM C1505	
	deep abrasion resistance	ASTM C1243	
	linear thermal expansion	ASTM C372	
	thermal shock resistance	ASTM C484	
	chemical resistance**	ASTM C650	
	frost resistance	ASTM C1026	
	bond resistance	ASTM C482	
	stain resistance	ASTM C1378	
	dimensions	edge warpage	ASTM C485
		diagonal warpage	ASTM C485
		nominal dimensions	ASTM C499
		caliber range	ASTM C499
		thickness	ASTM C499
		wedging	ASTM C502

SLIP RESISTANCE ACCORDING TO CERAMIC TILE INSTITUTE CLASSIFICATION			
TECHNICAL FEATURES		test method	
	coefficient of friction	ASTM C1028	
	dynamic coefficient of friction	ANSI A137.1	

*value referred to ceramic material only

**excluding hydrofluoridric acid and its derivatives

	LEA	LEA	LEA
requirements	average values	average values	average values
ANSI A137.1 porcelain tile - class P1	slimtech 3mm	slimtech 3plus (slab + fiberglass)	slimtech 5plus (slab + fiberglass)
≤ 0,5%	0.1%	0.1%*	0.1%*
-	≥ 6000 PSI	≥ 6000 PSI	≥ 6000 PSI
≤ 175 mm ³	compliant	compliant	compliant
no provision	$\alpha \leq 8 \cdot 10^{-6} \text{ } ^\circ\text{C}^{-1}$ $\alpha \leq 4.4 \cdot 10^{-6} \text{ } ^\circ\text{F}^{-1}$	$\alpha \leq 8 \cdot 10^{-6} \text{ } ^\circ\text{C}^{-1}$ $\alpha \leq 4.4 \cdot 10^{-6} \text{ } ^\circ\text{F}^{-1}$	$\alpha \leq 8 \cdot 10^{-6} \text{ } ^\circ\text{C}^{-1}$ $\alpha \leq 4.4 \cdot 10^{-6} \text{ } ^\circ\text{F}^{-1}$
no alterations	resistant	resistant	resistant
as indicated by manufacturer	A resistant	A resistant	A resistant C (lev)
as indicated by manufacturer	resistant	resistant	resistant
≥ 50 PSI	compliant	compliant	compliant
as indicated by manufacturer	A resistant	A resistant	A resistant C (lev)
± 0.40% or max ± 0.05 inch for tiles up to 24"x24" or max ± 0.07 inch for tiles larger than 24"x24"	compliant	compliant	compliant
± 0.40% or max ± 0.07 inch	compliant	compliant	compliant
- 3.0% / + 2.0% of nominal dimensions	± 0.5%	± 0.5%	± 0.5%
± 0.25% or max ± 0.03 inch	compliant	compliant	compliant
≤ 0.040 inch	≤ 0.030 inch	≤ 0.030 inch	≤ 0.030 inch
± 0.25% or max ± 0.03 inch	compliant	compliant	compliant

	LEA	LEA	LEA
requirements	average values	average values	average values
	slimtech 3mm	slimtech 3plus	slimtech 5plus
COF < 0.50 questionable 0.50 ≤ COF < 0.50 conditionally slip resistant COF ≥ 0.60 slip resistant	not required wall tiles	dry - neolite COF ≥ 0.60 wet - neolite COF ≥ 0.60 (gouache-10 - shade basaltina stone project)	dry - neolite ≥ 0.60 wet - neolite ≥ 0.60 (wood-stock)
DCOF ≥ 0.42 (wet internal spaces)	not required wall tiles	DCOF ≥ 0.42 (gouache-10 - shade basaltina stone project)	DCOF ≥ 0.42 (wood-stock - absolute sat timeless marble sat)

CARATTERISTICHE TECNICHE: GRES PORCELLANATO 20mm

TECHNICAL FEATURES PORCELAIN TILES
20mm

CARACTÉRISTIQUES TECHNIQUES
DU GRÉS CÉRAME 20mm

TECHNISCHE EIGENSCHAFTEN
DES GRES FEINSTEINZEUGS 20mm

CONFORME - ACCORDING TO - CONFORME - GEMÄß:
ISO 13006 G - EN 14411 G

CARATTERISTICHE TECNICHE
TECHNICAL FEATURES
CARACTÉRISTIQUES TECHNIQUES
TECHNISCHE EIGENSCHAFTEN



assorbimento d'acqua

water absorption
absorption d'eau
wasserabsorption



resistenza alla flessione

modulus of rupture
résistance à la flexion
beigefestigkeit



sforzò di rottura (S)

breaking strength (S)
chargement de rupture (S)
bruchlast (S)



classe requisiti meccanici

mechanical classification
résistance mécanique
klasse mechanisches Erfordernis



resistenza all'abrasione profonda

résistance to deep abrasion
résistance à l'abrasion profonde
widerstand gegen tiefenabrieb



dilatazione termica lineare

linear thermal expansion
dilatation thermique linéaire
thermische dilatation



resistenza agli sbalzi termici

thermal shock resistance
résistance aux chocs thermiques
temperaturwechselbeständigkeit



resistenza al gelo

frost resistance
résistance au gel
frostbeständigkeit



resistenza attacco chimico*

chemical resistance
résistance chimique
chemische beständigkeit
resistencia unión química



resistenza alle macchie

stain resistance
résistance aux taches
fleckenbeständigkeit



caratteristiche dimensionali

dimensions
caractéristiques dimensionnelles
scitenmasse

*ad esclusione dell'acido fluoridrico e suoi
derivati
excluding hydrofluoric acid and its derivatives
sauf l'acide fluorhydrique et ses dérivés
ausgenommen den fluorwasserstoff und seine
derivate

		LEA	
metodo di prova test method méthode d'essai prüfmethode		requisiti prescritti required values valeur requise vorgeschriebener wert ISO 13006 - G / EN 14411 - G gruppo / group Bla	valori medi average values valeurs moyens durchschnittliche werte UGL: non smaltato UGL: unglazed
ISO 10545-3		≤ 0,5%	0,05%
ISO 10545-4		≥ 35 N/mm ²	50 N/mm ²
ISO 10545-4		≥ 1300 N	13600 N
EN 1339-F		non richiesto not required nicht erforderlich pas nécessaire	T11
ISO 10545-6		≤ 175 mm ³	145 mm ³
ISO 10545-8		requisito non previsto no provision non prévu nicht erforderlich	$\alpha \leq 7 \times 10^{-6} \text{ } ^\circ\text{C}^{-1}$
ISO 10545-9		nessuna alterazione no alterations aucune altération keine änderung	resistente resistant résistant beständig
ISO 10545-12		nessuna alterazione no alterations aucune altération keine änderung	resistente resistant résistant beständig
ISO 10545-13		come indicato dal produttore as indicated by manufacturer comme indiqué par le producteur wie vom hersteller angegeben	ULA - UHA (resistente) (resistant) (résistant) (beständig)
ISO 10545-14		classe 3 min.	5 (resistente) (resistant) (résistant) (beständig)
lunghezza e larghezza length and width longueur et largeur länge und breite	ISO 10545-2	± 0,6%	conforme compliant conforme gemäß
retteilinearità spigoli straightness of sides rectitude des arêtes kantengeradheit	ISO 10545-2	± 0,5%	conforme compliant conforme gemäß
ortogonalità rectangularity orthogonalité rechtwinkligkeit	ISO 10545-2	± 0,6%	conforme compliant conforme gemäß
planarità warpage planéité ebenflächigkeit	ISO 10545-2	± 0,5%	conforme compliant conforme gemäß
spessore thickness épaisseur stärke	ISO 10545-2	± 5%	conforme compliant conforme gemäß

TECHNICAL FEATURES: PORCELAIN TILES 20mm

(AMERICAN STANDARDS)

ACCORDING TO ANSI A 137.1
UNGLAZED PORCELAIN TILES (CLASS P1)

TECHNICAL FEATURES



water absorption



breaking strength



deep abrasion resistance



linear thermal expansion



thermal shock resistance



chemical resistance*



frost resistance



bond resistance



stain resistance



dimensions

*excluding hydrofluoric acid and its derivatives

		LEA		
test method ASTM		required values		values
		ANSI A137.1		UGL: unglazed
ASTM C373		≤ 0.5%		0.05%
ASTM C648		≥ 250 lbf		2800 lbf
ASTM C1243		≤ 175 mm ³		145 mm ³
ASTM C372		no provision		$\alpha \leq 8 \times 10^{-6} \text{ } ^\circ\text{C}^{-1}$ $\alpha \leq 4.4 \times 10^{-6} \text{ } ^\circ\text{F}^{-1}$
ASTM C484		no alterations		resistant
ASTM C650		as indicated by manufacturer		A resistant
ASTM C1026		not required		resistant
ASTM C482		≥ 50 PSI		compliant
ASTM C1378		as indicated by manufacturer		A resistant
edge warpage	ASTM C485	rectified ± 0.40% or max ± 0.05 inch for tiles up to 24"x24" or max ± 0.07 inch for tiles larger than 24"x24"	calibrated ± 0.75% or max ± 0.09 inch	compliant
diagonal warpage	ASTM C485	rectified ± 0.40% or max ± 0.07 inch	calibrated ± 0.50% or max ± 0.08 inch	compliant
nominal dimensions	ASTM C499	rectified - 3.0% / + 2.0% of nominal dimensions	calibrated ± 3.0% of nominal dimensions	± 1.5%
caliber range	ASTM C499	rectified ± 0.25% or max ± 0.03 inch	calibrated ± 0.50% or max ± 0.08 inch	compliant
thickness	ASTM C499	≤ 0.040 inch	≤ 0.040 inch	≤ 0.030 inch
wedging	ASTM C502	rectified ± 0.25% or max ± 0.03 inch	calibrated ± 0.50% or max ± 0.08 inch	compliant

CARATTERISTICHE PRODOTTO: LEALAB - PIXEL - TYPE32

PRODUCT CHARACTERISTICS:
LEALAB - PIXEL - TYPE32

CARACTÉRISTIQUES DU PRODUIT:
LEALAB - PIXEL - TYPE32

PRODUKT-EIGENSCHAFTEN:
LEALAB - PIXEL - TYPE32

inchiostri inks encres Tinten	base acqua water-based base eau auf Wasserbasis
protettivi protective layers protecteurs Schutzmittel	base acqua water-based base eau auf Wasserbasis
resistenza dei colori alla luce DIN 51094 resistance of colours to light DIN 51094 résistance des couleurs à la lumière DIN 51094 Lichtbeständigkeit der Farben nach DIN 51094	superficie inalterata surface unaltered surface inaltérée unveränderte Oberfläche
resistenza attacco chimico ISO 10545-13 chemical resistance ISO 10545-13 résistance chimique ISO 10545-13 chemischee beständigkeit ISO 10545-13	GLA - GHA resistente GLA - GHA resistant GLA - GHA résistant GLA - GHA beständig
resistenza alle macchie stain resistance résistance aux taches fleckenbeständigkeit	resistente al contatto con alimenti e bevande resistant to contact with food and drink résistant au contact avec les aliments et les boissons Widerständigkeit beim Kontakt mit Lebensmitteln und Getränken
pulizie quotidiane daily cleaning nettoyages quotidiens Tägliche Reinigung	utilizzare solo detersivi neutri, non utilizzare spugne o paste abrasive use only neutral detergents, do not use abrasive sponges or paste utiliser uniquement des détergents neutres, ne pas utiliser d'éponges ou de pâtes abrasives nur neutralen Reinigungsmitteln verwenden, keine Schleifmittel oder Schleifschwämme verwenden
resistenza superficiale surface strength surface résistante Oberflächenwiderstand	per preservare l'unicità della superficie evitare il contatto con elementi graffianti to preserve the integrity of the surface avoid contact with abrasive materials a fin de préserver le caractère unique de la surface, évitiez le contact avec des éléments abrasifs Für den Erhalt der Einzigartigkeit der Oberfläche den Kontakt mit kratzenden Elementen vermeiden
taglio cut découpe Schnitt	per garantire l'impermeabilità della superficie, in caso di necessità di tagliare la singola lastra stuccare il bordo tagliato utilizzando prodotti epossidici * in order to guarantee the impermeability of the surface, if it becomes necessary to cut the individual slab the cut edge must be plastered with an epoxy product pour garantir l'étanchéité de la surface, en cas de nécessité de couper la plaque seule plâtrez le bord découpé en utilisant des produits époxydes Zur Gewährleistung der Dichtheit der Oberfläche, die einzelne Platte falls notwendig schneiden und den geschnittenen Rand mit Epoxydprodukten behandeln
stucco grout mastic Fugenmaterial	il prodotto si può stuccare sia con prodotti epossidici che con prodotti cementizi; * in caso di utilizzo con stucchi epossidici proteggere la superficie con nastro adesivo per mascheratura the product can be grouted using both epoxy and cement products; * if epoxy grouts are used, protect the surface with masking tape le produit peut être enduit avec des mastics à base d'époxy ou de ciment; * si l'on utilise des mastics époxy, protéger la surface avec du ruban adhésif à protection das Produkt kann man mit Epoxyd-oder-Zementfugen ausfügen; * Beim Verwenden von Epoxyd-Fugenmaterial muss man die Oberfläche sorgfältig schützen Mit Klebband

MANUALI TECNICI

TECHNICAL MANUALS

MANUELS TECHNIQUES

TECHNISCHE HANDBÜCHER

404/405

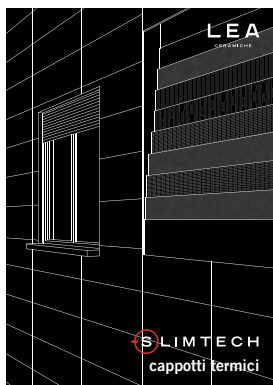

CAPPOTTI TERMICI
external wall thermal insulation
murs manteaux thermiques
Wärmedämmungen

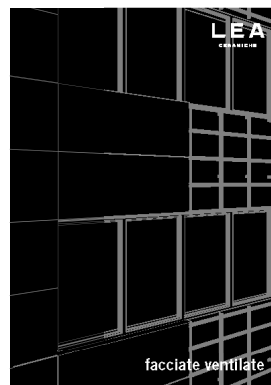

FACCIATE VENTILATE
ventilated walls
façades ventilées
Hinterlüftete Fassaden

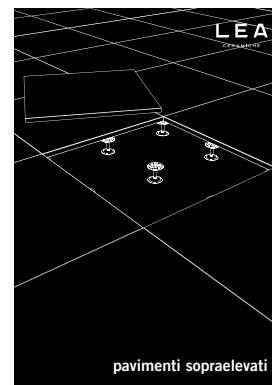

PAVIMENTI SOPRAELEVATI
raised floors
sols surélevés
Doppelboden

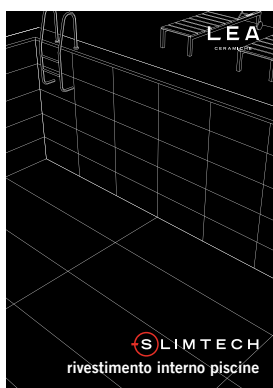

RIVESTIMENTO INTERNO PISCINE
swimming pools
revêtements piscines
Schwimmbeckenverkleidung

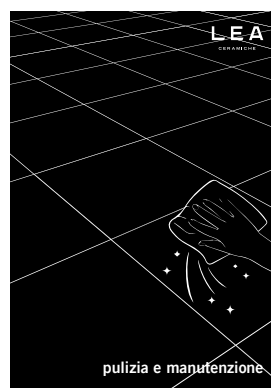

PULIZIA E MANUTENZIONE
cleaning and maintenance
nettoyage et entretien
Reinigung und Wartung

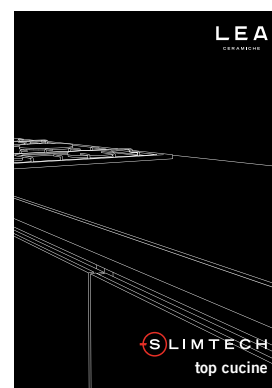

TOP CUCINE
kitchen countertops
plan de travail cuisine
Küchenarbeitsplatte

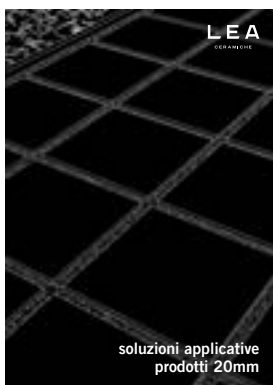

SOLUZIONI APPLICATIVE PRODOTTI 20mm
application solutions for 20mm products
solutions applicatives produit 20mm
Anwendungslösungen für 20mm Produkte



MANUALE TECNICO SLIMTECH
slimtech technical manual
manuel technique slimtech
slimtech technisches handbuch



MANUALE TECNICO PROTECT
protect technical manual
manuel technique protect
protect technisches handbuch

I manuali tecnici sono disponibili sul sito internet www.ceramichelea.com

The technical manual is available on the website www.ceramichelea.com
Les manuels techniques sont disponibles sur le site Internet www.ceramichelea.com
Die Technischen Broschüren sind auf der Webseite www.ceramichelea.it erhältlich.

POSA GRADINO PLUS, ELEMENTO AD ELLE E GRADINO CONTINUO

Effettuare sempre la posa con adesivo. Per la posa su sottofondi cementizi utilizzare adesivi elastici di classe S2 secondo EN 12004. Nel caso di posa su altri supporti (es. legno, truciolare...) contattare i fornitori per la scelta dell'adesivo più idoneo. Verificare che il sottofondo sia stabile, planare e pulito. Gli strati cementizi (massetti, calcestruzzo, strati di livellamento/pendenza...) devono essere stagionati, cioè devono aver esaurito i fenomeni di ritiro. Evitare la presenza di acqua sul sottofondo. Nel caso in cui la pavimentazione in esercizio sarà a contatto con l'acqua (ambienti esterni, centri benessere, docce, spogliatoi...) è necessario:

- realizzare sottofondi con pendenza di almeno l'1% (1 cm per ogni metro);
- applicare idonei impermeabilizzanti sulla superficie del sottofondo;
- miscelare gli stucchi con idonei lattici che riducano la porosità delle fughe.

NON LASCIARE VUOTI sotto agli Elementi ad Elle, Gradini Continui e Gradini Plus, posare con "doppia spalmatura" anche nella parte verticale dei pezzi. Il bordo verticale di Elementi ad Elle, Gradini Continui e Gradini Plus deve essere distanziato di alcuni mm (almeno 3-4 mm) dal sottofondo e lo spazio vuoto deve essere riempito con collante, v. figure.

Calpestare Elementi ad Elle, Gradini Continui e Gradini Plus e riempire le fughe solo quando l'adesivo ha fatto presa secondo le indicazioni riportate dai fabbricanti. Posare sempre con la fuga, che dovrà avere idonee dimensioni e comunque calcolata dal progettista. Prevedere nella pavimentazione i giunti perimetrali a contatto con elementi strutturali verticali (muri, colonne...) ed idonei giunti di dilatazione. Evitare sistemi rigidi:

- volendo rivestire la parte verticale degli scalini ("alzata"), posare il materiale ben distanziato da Elementi ad Elle, Gradini Continui e Gradini Plus, come mostrato nelle figure.
- nel caso di terrazze o balconi, assicurarsi che le eventuali grondaie siano un sistema a sé stante, cioè siano ben distaccate da Elementi ad Elle e Gradini Plus.

LAYING OF PLUS STEP, ELLE SHAPED ELEMENT AND CONTINUED STEP

Always lay using adhesive. When laying on cement bases use elastic class S2 EN 12004 compliant adhesive. When laying on other bases (e.g. wood, chipboard...) contact suppliers for the choice of the best adhesive. Check that the base is stable, flat and clean. Cement layers (screed, concrete, levelling/sloping layers...) must be seasoned, that is must have withdrawn completely. Avoid any water on the base. If flooring in use is in contact with water (exteriors, wellness centres, showers, changing rooms...) you need to:

- create bases with a slope of at least 1% (1 cm for each metre)
- apply suitable waterproofing to the base
- mix the stucco with suitable latexes to reduce porosity of fugues.

DO NOT LEAVE EMPTY SPACES under the Elle Shaped Element, Continued Steps and Plus Steps; lay by "double spreading" even for vertical parts. The vertical parts of Elle Shaped Element, Continued Steps and Plus Steps must be spaced a few mm (at least 3-4 mm) from the base and the empty space must be filled with glue, see pictures. Walk on the Elle Shaped Element, Continued Steps and Plus Steps and only fill the fugues when the adhesive holds following manufacturer instructions. Always lay with fugues of the right size, calculated by the designer. Plan for perimeter joints in flooring coming into contact with vertical structural elements (walls, columns...) and suitable expansion joints.

Avoid rigid systems:

- if you want to cover the vertical part of steps ("rise"), lay the material the right distance from the Elle Shaped Element, Continued Steps and Plus Steps, as shown in the pictures.
- for terraces and balconies, makes sure any gutters are a system to themselves; that is are well separated from the Elle Shaped Element and Plus Steps.

POSE MARCHE PLUS, ÉLÉMENT À ELLE ET NEZ MARCHE CONTINUE

Effectuer toujours la pose collée. Pour la pose sur les sous-couches en ciment, utiliser des colles élastiques en classe S2 conformes à la norme EN 12004.

En cas de pose sur d'autres supports (ex. bois, laminé...) contacter les fournisseurs pour le choix de la colle la plus adaptée. Vérifier que la sous-couche est stable, plane et propre. Les temps de séchage du support (chapes, béton armé, ragréage...) doivent être parfaitement respectés c'est-à-dire que les phénomènes de retrait doivent être terminés.

Éviter la présence d'eau sur la sous-couche. Si le sol à carrelé doit entrer en contact avec l'eau (pose en extérieur, Spa, douches, vestiaires...) il faudra:

- réaliser une sous-couche avec une pente d'au moins 1% (1 cm/mètre)
- appliquer des imperméabilisants appropriés sur la sous-couche
- mélanger les mastics avec des latex appropriés qui réduisent la porosité des jointes.

NE PAS LAISSER DE VIDES sous les éléments à «L» et des nez de marche «Plus» et «Continue»; appliquer la colle avec la technique du double encollage (support et envers des carreaux), ainsi que sur le bord vertical des carreaux. Le bord vertical des éléments en «L» et des nez de marche «Plus» et «Continue» doit être à une

GRADINO PLUS PLUS STEP / MARCHE PLUS STUFEN "PLUS"

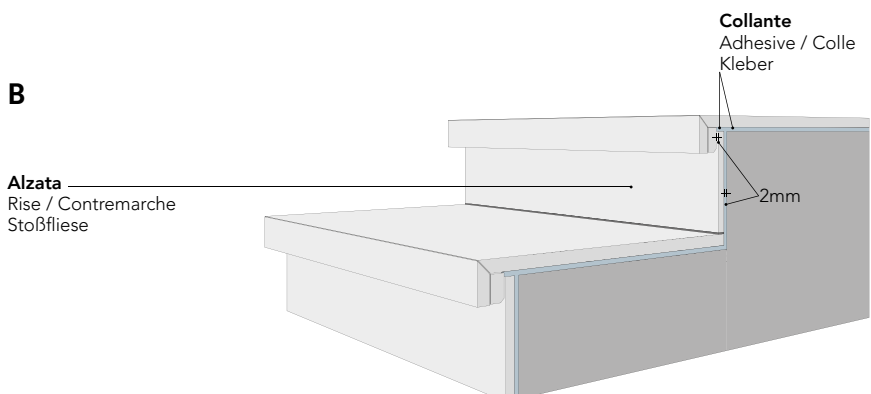
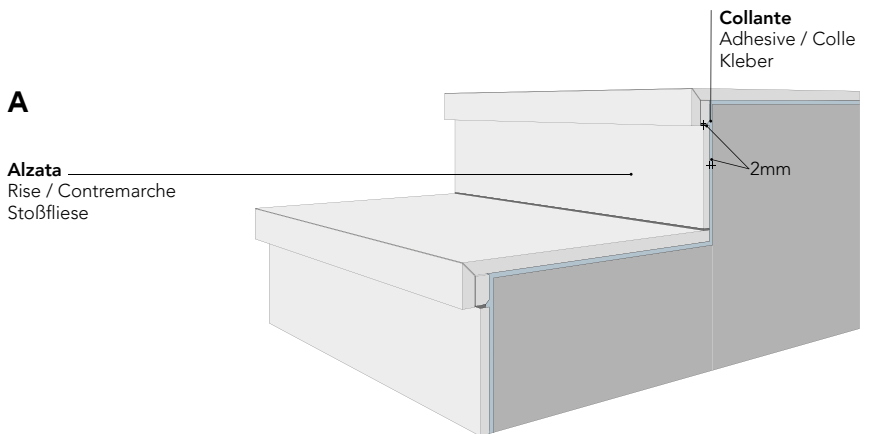

distance de au moins 3-4 mm de la sous-couche et l'espace vide doit être rempli avec de la colle, voir les figures. Marcher les éléments à «L» et des nez de marche «Plus» et «Continue» et remplir les joints seulement une fois que la colle a fait prise, selon les indications fournies par les fabricants. Poser toujours avec un joint dont les dimensions seront calculées par le projeteur. Prévoir sur le sol des joints périphériques aux points de contact avec les éléments structurels verticaux (mur, colonnes...) et des joints de dilatation opportuns. Éviter les systèmes rigides:

- si on souhaite carrelé la partie verticale des marches (contremarche), poser les carreaux à une certaine distance des éléments à «L» et des nez de marche «Plus» et «Continue» (voir les figures).
- pour les terrasses et les balcons, s'assurer que les gouttières sont totalement indépendantes, c'est-à-dire bien séparées des éléments à «L» et des nez de marche «Plus».

VERLEGUNG DES STUFEN "PLUS", ELLE-ELEMENTS UND DER DURCHGEHENDEN STUFEN

Zum Verlegen immer Kleber verwenden. Zum Verlegen auf zementhaltigem Untergrund elastische Kleber der Klasse S2 gemäß EN 12004 verwenden. Wenden Sie sich beim Verlegen auf anderen Unterlagen (z.B. Holz, Spanplatten usw.) für die Wahl des geeigneten Klebers an die Händler. Prüfen Sie, dass der Verlegeuntergrund stabil, eben und sauber ist. Die zementhaltigen Schichten (Estrich, Betonuntergrund, Nivellierschicht bzw. Gefälle, usw.) müssen abgelagert sein, d.h. die Schrumpfung muss abgeschlossen sein. Es darf sich kein Wasser auf dem Untergrund befinden. Sollte der zu verlegende Fußboden in Kontakt mit Wasser gelangen (Außenbereiche, Wellness-Center, Duschen, Umkleieräume usw.) ist Folgendes zu beachten:

- Den Verlegeuntergrund mit einer Neigung von mindestens 1% erstellen (1 cm pro Meter)
- Geeignete Dichtstoffe auf der Oberfläche des Untergrunds anbringen
- Die Gipsmörtel mit einem geeignetem Latex mischen, um die Durchlässigkeit der Fugen zu verringern.

KEINE LEERRÄUME unter den "L"-Schenkel, lange Stufenplatten, Stufen "Plus" HINTERLASSEN; auch den vertikalen Abschnitt der Elemente mit "Doppelbeschichtung" verlegen. Die vertikale Kante der "L"-Schenkel, lange Stufenplatten, Stufen "Plus" muss einige mm Abstand (mind. 3-4 mm) zum Verlegeuntergrund aufweisen; dabei ist der Leerraum mit Kleber zu füllen, siehe Abbildungen. Die "L"-Schenkel, lange Stufenplatten, Stufen "Plus" betreten und die Fugen erst verschließen, nachdem der Kleber entsprechend der Herstellerangaben gehärtet ist. Immer mit der Fuge verlegen, wobei deren Größe, die vom Projektplaner berechnet wird, angemessen sein muss. Kalkulieren Sie bei der Fußbodenverlegung die umlaufenden Fugen, welche mit vertikalen Konstruktionselementen (Mauern, Säulen, usw.) in Kontakt stehen, sowie die Dehnungsfugen mit ein.

Vermeiden Sie starre Systeme:

- Bei der Verkleidung des vertikalen Abschnitts der Stufen ("Setzstufe") das Material in einem angemessenen Abstand zu den "L"-Schenkel, lange Stufenplatten, Stufen "Plus" verlegen, siehe Abbildungen.
- Bei Terrassen oder Balkons sicherstellen, dass die evtl. vorhandenen Dachrinnen ein unabhängiges System darstellen, d.h. einen angemessenen Abstand zu den "L"-Schenkel, Stufen "Plus" aufweisen.

GRADINO CONTINUO

CONTINUED STEP / MARCHE CONTINUE
DURCHGEHENDEN STUFEN

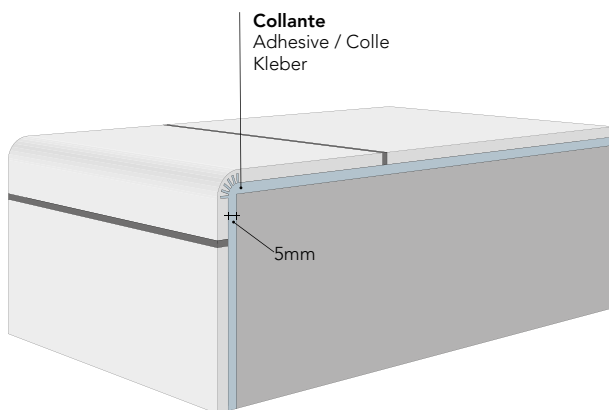

GRADINO CONTINUO

CONTINUED STEP / MARCHE CONTINUE
DURCHGEHENDEN STUFEN

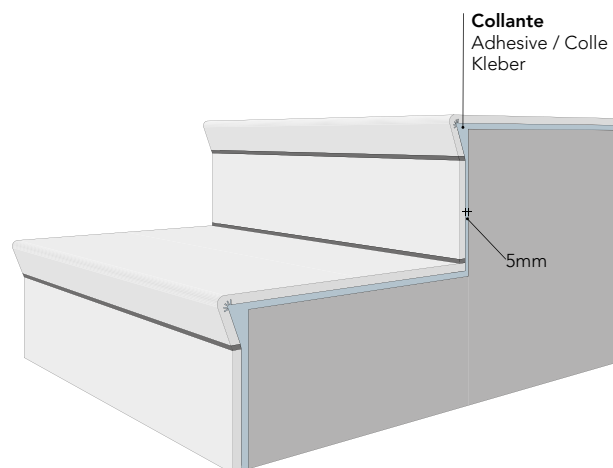

Tutti i gradini continui sono da posare esclusivamente in interno.

All steps are intended as "indoor use" only.

Tous les nez de marche sont à utiliser exclusivement à l'intérieur.

Alle Stufenplatten sind ausschließlich für die Verlegung im Innenbereich geeignet.

INFORMAZIONI PER LA PULIZIA E LA MANUTENZIONE

Prima di pulire una superficie piastrellata è bene:

1. Verificare sul catalogo generale la **resistenza agli agenti chimici** delle piastrelle posate;
2. Effettuare un test preliminare direttamente sulle piastrelle posate, ponendo il detergente da utilizzare a contatto con le piastrelle per tempi uguali a quelli che si useranno poi sul cantiere;
3. Assicurarsi che i detersivi da usare **non contengano** acido fluoridrico e/o suoi derivati, poiché tali sostanze, per loro peculiarità, aggrediscono tutti i prodotti ceramici.

Si riportano di seguito alcune indicazioni per le pulizie di fine cantiere ("dopo posa"), quotidiane, straordinarie, per la rimozione di cere e patine lucidanti e per eventuali manutenzioni straordinarie.

Pulizia "dopo posa"

1. La pulizia "dopo posa" serve per rimuovere i residui di stucchi per le fughe, cemento, calce, boiaccia. È obbligatoria a fine cantiere, sia per le piastrelle smaltate che per quelle non smaltate.
2. Una pulizia "dopo posa" male effettuata, o addirittura non fatta, è spesso causa di aloni che impediscono di mantenere pulito il pavimento nonostante una buona pulizia quotidiana.
3. Quando possibile, specialmente per superfici medio-grandi, si consiglia l'uso di monospazzola con dischi morbidi (bianchi oppure beige).
4. Pulizia stucchi cementizi miscelati con acqua
Si effettua con specifici detersivi a base di acidi tamponati e diluiti. Alcuni di questi, facilmente reperibili in commercio, sono riportati nella seguente tabella.

RESIDUO DA RIMUOVERE	TIPO DI DETERGENTE	NOME DETERGENTI	PRODUTTORE
stucchi cementizi boiaccia cemento calce	a base di acidi tamponati	keranet	mapei
		cement remover	faberchimica
		deterdek	fila
		trek	kiter
		zementschleierentferner	lithofin
		hmk r63	hmk
		solvacid	geal
		bonaclean / bclean	bonasystems italia
		bonadecon / bdecon (*)	bonasystems italia

Salvo diversa indicazione di LEA CERAMICHE, seguire attentamente le modalità d'uso indicate sulle confezioni dai fabbricanti.

(*) Specifico per prodotti non resistenti agli acidi.

Indicazioni per la pulizia "dopo posa":

1. Effettuare la pulizia dopo 4-5 giorni dalla stuccatura (lo stucco deve indurire) e non oltre 10 giorni. Oltre questi tempi la pulizia può diventare molto più laboriosa.
2. Bagnare con acqua il pavimento prima delle operazioni di pulizia. In questo modo le stucature vengono impregnate dall'acqua e viene ridotto il contatto con i detersivi.
3. Lasciare agire i detersivi per tempi limitati, risciacquando bene con acqua appena possibile.
4. Non deve essere eseguita se le superfici piastrellate sono molto calde (es. esposte al sole nei mesi più caldi), perché diviene più severa l'azione degli aggressivi chimici. In estate effettuarla nelle ore fresche della giornata.
5. Fare sempre test preventivi prima dell'uso (su una piastrella non posata), in particolare per prodotti Lappati o Levigati.

5. Pulizia stucchi epossidici, bi-componenti e reattivi

In questi casi la rimozione dei residui degli stucchi deve essere fatta immediatamente ed in modo molto accurato seguendo le indicazioni dei fabbricanti, perché questi stucchi induriscono molto rapidamente, anche in pochi minuti. Seguire attentamente le modalità di pulizia indicate dal fabbricante dello stucco utilizzato e verificarne l'efficacia (anche con un controllo) con una prova preliminare di pulizia prima di stuccare l'intero pavimento/parete.

6. piastrelle antiscivolo

Le piastrelle "antislip", realizzate con superfici ruvide e/o strutturate, si puliscono ovviamente in modo più laborioso. Si consiglia perciò di effettuare la pulizia "dopo posa" in modo rapido ed accurato, utilizzando quando possibile monospazzola con dischi bianchi e beige.

Pulizia straordinaria

Viene effettuata per rimuovere macchie o residui particolarmente vecchi o resistenti. Prima dell'uso fare sempre test preventivi (su una piastrella non posata), in particolare su **Lappati e Levigati**.

Nella tabella sotto sono indicati detergenti efficaci a seconda del tipo di macchia.

RESIDUO DA RIMUOVERE	TIPO DI DETERGENTE	NOME DETERGENTI	PRODUTTORE
grassi polvere da calpestio pulizie di fondo	polifunzionali, a base alcalina(1)	ps87	fila
		intensivreiniger	lithofin
		hmk r55	hmk
		taski r20-strip	johnsondiversey
		bonadecon / bdecon	bonasystems italia
		deterflash	geal
caffè coca-cola succhi di frutta	polifunzionali, a base alcalina(1)	coloured stain remover	faberchimica
		ps87	fila
		super deterjet	geal
vino	ossidante	candeggina	vari produttori
		oxidant candeggina	faberchimica vari produttori
depositi calcarei	a base acida (1)	viakal	procter & gamble
ruggine	a base acida (1)	acido muriatico diluito	vari produttori
inchiostr pennarello	a base solvente	diluyente nitro, acqua ragia	vari produttori
		coloured stain remover	faberchimica
pneumatici, segn di gomma di metalli di matita	pasta abrasiva (1)	vim clorex (2)	guaber
		polishing cream (2)	faberchimica
		strong remover (3)	faberchimica
		detergum (3)	zep italia
sporco delle fughe	specifico	fuganet	fila
		fugenreiniger	lithofin

(1) Fare test preventivo su materiali Lappati e Levigati

(2) Indicato per materiali Lappati e Levigati

(3) Non usare su prodotti Lappati, usare con molta attenzione sui Levigati

Salvo diversa indicazione di LEA CERAMICHE, seguire attentamente le modalità d'uso indicate sulle confezioni dai fabbricanti.

INFORMAZIONI PER LA PULIZIA E LA MANUTENZIONE

Pulizia quotidiana / ordinaria

Utilizzare acqua calda e un panno in microfibra di buona qualità, tipo MAGICCLEAN di **Bonasytems Italia**. Ogni tanto, ad es. ogni 10-20 giorni a seconda dello stato della pavimentazione, utilizzare detergenti neutri molto diluiti in acqua calda, che non contengono cere o non depositano patine lucide. A fine lavaggio risciacquare sempre con acqua, utilizzando un secondo panno in microfibra di buona qualità.

TIPO DI OPERAZIONE	TIPO DI DETERGENTE	NOME DETERGENTI	PRODUTTORE
pulizie quotidiane	neutro	floor cleaner	faberchimica
		fila cleaner	fila
		pfleregereiniger	lithofin
		hmk p15	hmk
		bonamain + / bmain +	bonasytems italia
		bonatitania clean / bitania clean	bonasytems italia
		belgres	geal

Salvo diversa indicazione di LEA CERAMICHE, seguire attentamente le modalità d'uso indicate sulle confezioni dai fabbricanti.

Pulizia decori

- Utilizzare detergenti NEUTRI e diluiti.
- NON UTILIZZARE ASSOLUTAMENTE**
- Ceranti e/o impregnanti
- Detergenti acidi o alcalini
- Paste abrasive
- Spazzole o spugne abrasive.

Rimozione di patine lucide

Nei normali detergenti in commercio sono a volte contenute cere o additivi lucidanti che, lavaggio dopo lavaggio, depositano sul pavimento **patine lucide**, causa di noiose alonature. Patine di questo tipo possono essere depositate anche da alcuni stucchi per le fughe.

Semplici alimenti come Coca Cola, vino, acqua, etc., cadendo sul pavimento tolgono questa patina lucida e ripristinano l'**aspetto originale** più opaco delle piastrelle. In mezzo al pavimento più lucido, le zone senza cera appaiono come aloni opachi, in realtà sono le uniche parti pulite del pavimento. In questi casi bisogna:

1. Prima di tutto togliere la patina lucida da tutto il pavimento (vedi tabella seguente);
2. Poi, per le pulizie quotidiane, utilizzare detergenti neutri che non contengano né cere né patine lucidanti (vedi paragrafo precedente "pulizie quotidiane/ordinarie").

RESIDUO DA RIMUOVERE	TIPO DI DETERGENTE	NOME DETERGENTI	PRODUTTORE
patine lucide	debolmente acidulo	tile cleaner puro (*)	faberchimica

(*) Non seguire le indicazioni sulla confezione, ma applicare il detergente puro, lasciare agire per 5-10 minuti, frizionare con tamponi morbidi (bianco, giallo) e sciacquare bene con acqua.

Non utilizzare cere su gres porcellanato LEA CERAMICHE.

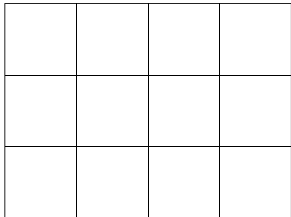
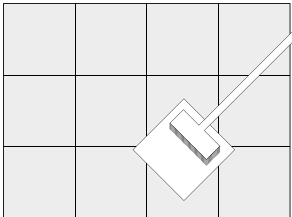
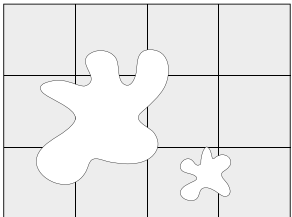
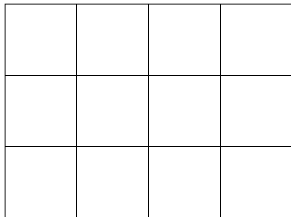
1  Pavimento originale.	2  Dopo pulizia con detergenti contenenti cere.	3  Semplici alimenti (Coca-Cola, vino, acqua...) possono togliere la patina lucida. La superficie originale è più opaca.	4  Rimuovere la patina con detergente (Tile Cleaner puro, Faber) ed utilizzare quotidianamente un detergente senza cere.
---	---	---	--

Protettivi per fughe

NOME PRODOTTO	PRODUTTORE
fugaproof	fila
kf fugenschutz	lithofin

Salvo diversa indicazione di LEA CERAMICHE, seguire attentamente le modalità d'uso indicate sulle confezioni dai fabbricanti.

Trattamenti antislip

La resistenza allo scivolamento dei pavimenti posati (sia piastrelle smaltate che non smaltate) può essere aumentata utilizzando specifici prodotti (vedi tabella). Prima di applicare il prodotto sul pavimento fare test preventivi su piastrelle non posate per trovare i tempi di contatto più idonei. Se da un lato tempi più lunghi aumentano il grado di grip, dall'altro tendono un po' a sbiancare i colori delle piastrelle e a renderle un pochino più sporcabili.

TIPO DI OPERAZIONE	NOME PRODOTTO	PRODUTTORE
trattamento antislip	bonagrip	bonasystems italia

attenzione:

1. Non usare questi trattamenti su superfici Lappate né Levigate;
2. Prima del trattamento contattare Servizio Clienti Lea;
3. Si consiglia di realizzare il trattamento tramite ditte specializzate.

I prodotti **LEVIGATI** possono raggiungere il grado **R9** (test DIN51130) con appositi trattamenti al laser, eseguibili solo sul materiale non posato: per questo la richiesta di R9 su Levigati deve essere specificata al momento dell'ordine all'ufficio commerciale.

Tali trattamenti al laser possono essere seguiti anche su superfici **LAPPATE** (dopo verifica Servizio Clienti LEA CERAMICHE).

Riferimenti utili pag. 424

Il manuale tecnico "pulizia e manutenzione" è disponibile sul sito internet www.ceramichelea.com

CLEANING AND MAINTENANCE INFORMATION

Make sure to do the following before cleaning any tiled surface:

1. Check the **resistance to chemical agents** of the laid tiles on the general catalogue;
2. Make a preliminary test directly on the laid tiles by putting a detergent, to be used in contact with the tiles for a period that is equal to the period that will be used later on the site;
3. Make sure that the detergents that are going to be used, **do not contain** hydrofluoric acid and/or any of its derivatives; these substances are distinctively known for damaging **all** ceramic products.

Some indications for cleaning after the installation (after laying the tiles), on a daily basis, extra cleaning and to remove waxes and polish glazes or for any extra maintenance that may be required, are listed here below.

Cleaning “after the installation”

1. Cleaning “after the installation” helps remove residues of grout-joints, cement and lime. This is obligatory at the end of the installation, for glazed tiles and unglazed tiles.
2. If the cleaning “after the installation” is not carried out properly or if is not carried out at all, is often a cause of marks that prevent the floor from being clean even if a good daily cleaning is performed.
3. Whenever is possible, especially for medium to large surfaces, it is advisable to use a single-brush machine with soft disks (white or beige).
4. cleaning cement-based grouts mixed with water.
It is carried out with specific detergents based with buffered and diluted acids. The table below shows some of these detergents, which are easily available in the market.

FOR REMOVING THE FOLLOWING RESIDUES	TYPE OF DETERGENT	DETERGENT'S NAME	MANUFACTURER
cement-based grouts grout cement lime	buffered acid based	keranet	mapei
		cement remover	faberchimica
		deterdek	fila
		trek	kiter
		zementschleierentferner	lithofin
		hmk r63	hmk
		solvacid	geal
		bonaclean / bclean	bonasystems italia
		bonadecon / bdecon (*)	bonasystems italia

Unless otherwise indicated by LEA CERAMICHE, follow the instructions indicated on the manufacturer's package very carefully.

(*) Specific for products that are non-resistant to acids

Unless otherwise indicated by LEA CERAMICHE, follow the instructions indicated on the manufacturer's package very carefully.

Instructions on how to clean “after the installation”:

1. Clean 4-5 days after the grouting (the grout must be hardened); do not wait over 10 days. In addition to this period, the cleaning can become very laborious.
2. Moisten the floor with water before cleaning. This way the groutings are soaked with water and the contact with detergents is reduced.
3. Let the detergents operate for limited periods, hence rinse out with water as soon as possible.
4. It must not be carried out if the tiled surfaces are very hot (i.e. exposed to the sun during very warm days); this must be avoided as the action of aggressive chemicals become very harsh. On the summer, proceed with the operation during the coolest period of the day.
5. Make sure to always perform a precautionary test before using the product (on a tile that is not laid), especially for Lapped or Polished products.

5. cleaning for epoxy, bi-component and reagent grouts

In these cases the removal must be carried out immediately and carefully following the recommendations of the manufacturers, as these grouts harden very fastly, even in a few minutes. Please carefully follow the cleaning mode specified by the manufacturer of the grout used; verify its effectiveness (backlight also) with a preliminary cleaning test before grouting the entire floor/wall.

6. antislip tiles

"Antislip" tiles that are made with rough and/or textured surfaces must be cleaned very laboriously. Therefore, it is advisable to clean "after the installation", quickly and thoroughly, using a single-brush machine with disks white and beige.

Extraordinary cleaning

This procedure is carried out to remove stains or residues that are particularly old or tough. Make sure to always perform a precautionary test before using the product (on a tile that is not laid), especially for **Lapped** or **Polished** products. The table shown below indicates the detergents that are effective according to the type of stains.

FOR REMOVING THE FOLLOWING RESIDUES	TYPE OF DETERGENT	DETERGENT'S NAME	MANUFACTURER
grease dust footmarks base cleaning	multipurpose, alkaline-based (1)	ps87	fila
		intensivreiniger	lithofin
		hmk r55	hmk
		taski r20-strip	johnsondiversey
		bonadecon / bdecon	bonasystems italia
		deterflash	geal
coffee coke fruit juice	multipurpose, alkaline-based (1)	coloured stain remover	faberchimica
		ps87	fila
		super deterjet	geal
		bleach	various manufactures
wine	oxidizing agent	oxidant	faberchimica
		bleach	various manufactures
calcareous deposits	acid-based (1)	viakal	procter & gamble
rust	acid-based (1)	dilute hydrochloric acid	various manufactures
inks felt-tipped pen	solvent-based	nitro thinner, turpentine	various manufactures
		coloured stain remover	faberchimica
pneumatic stains from rubber metals or pencils	abrasive paste (1)	vim clorex (2)	guaber
		polishing cream (2)	faberchimica
		strong remover (3)	faberchimica
		detergum (3)	zep italia
tile joint stains	specific	fuganet	fila
		fugenreiniger	lithofin

(1) Make precautionary test on Lapped or Polished materials

(2) Suitable for Lapped or Polished materials

(3) Do not use it on Lapped; use it with the utmost caution on Polished products

Unless otherwise indicated by LEA CERAMICHE, follow the usage instructions indicated on the manufacturer's package very carefully.

CLEANING AND MAINTENANCE INFORMATION

Daily / standard cleaning

Use warm water and a good quality microfibre cloth, such as MAGICCLEAN by **Bonasystems Italy**. Every now and again, e.g. every 10-20 days depending on the state of the flooring, use neutral detergents diluted with hot water, that are wax-free, and do not deposit glossy stains. When the cleaning process is finished always rinse with water, using a second good quality microfibre cloth.

TYPE OF OPERATION	TYPE OF DETERGENT	DETERGENT'S NAME	MANUFACTURER
clean on a daily basis	neutral	floor cleaner	faberchimica
		fila cleaner	fila
		pflgereiniger	lithofin
		hmk p15	hmk
		bonamain + / bmain +	bonasystems italia
		bonatitania clean / btitania clean	bonasystems italia
		belgres	geal

Unless otherwise indicated by LEA CERAMICHE, follow the instructions indicated on the manufacturer's package very carefully.

Cleaning decorations

- Use NEUTRAL, diluted detergents
- NEVER USE**
- Waxing and impregnating agents
- Acid or alkaline detergents
- Abrasive pastes
- Abrasive brushes or sponges.

Removing glossy glaze

Standard detergents that are available in the market sometimes contain waxes or polish additives that, wash after wash, deposit **glossy glaze** on the floor and causes annoying marks. These types of glazes can also settle on some joint grouts.

When simply types of foods such as Coke, wine, water, etc., fall on the floor, they remove this type of glossy glaze and restore the **original appearance** of the tiles (a more opaque look).

In the middle of the shinier floor, the areas without wax appear as opaque marks, but they are actually the only clean parts of the floor. In these cases, the following must be done:

1. First of all, remove the glossy glaze from the entire floor (see table below);
2. Then, for daily cleaning, use neutral detergents that do not contain wax or polishing glaze (see the previous paragraph: "daily/standard cleaning").

RESIDUES TO BE REMOVED	TYPE OF DETERGENT	DETERGENT'S NAME	MANUFACTURER
glossy glaze	weak acidulous	tile cleaner pure (*)	faberchimica

(*) Do not follow the instructions on the package, just apply the pure detergent, leave it on for 5-10 minutes, rub it with soft pads (white, yellow) and rinse it thoroughly with water.

Do not use wax on LEA CERAMICHE porcelain stoneware.

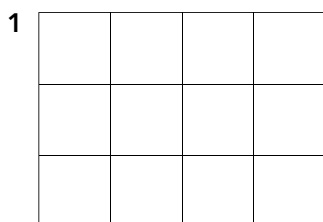

Original floor.

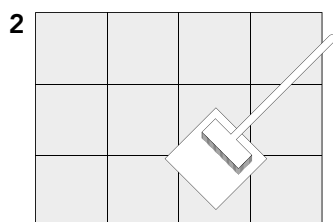

After cleaning detergents containing waxes.

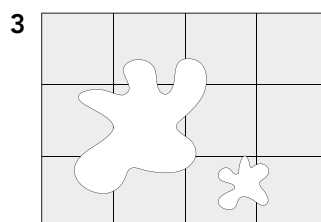

Simple foodstuffs (Coca-Cola, wine, water etc) can remove the bright patina. The original surface is more matt.

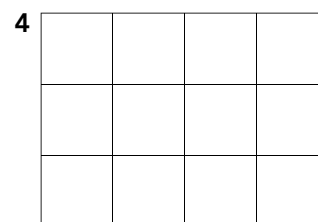

Remove the patina with detergent (Faber tile cleaner, used neat), and use detergent without waxes for everyday cleaning.

Special maintenance

Stain-resistant products for joints

PRODUCT NAME	MANUFACTURER
fugaproof	fila
kf fugenschutz	lithofin

Unless otherwise indicated by LEA CERAMICHE, follow the instructions indicated on the manufacturer's package very carefully.

Antislip treatments

The slip resistance of floors laid with glazed tiles or non-glazed tiles can be increased by using specific products (see table).

Before applying the product make a precautionary test on a tile that is not laid in order to find the most suitable contact time. If, on the one hand, the longest period increases the gripping grade, on the other, it will tend to whiten the colours of the tiles a little and make it a little easier to stain.

TYPE OF OPERATION	PRODUCT NAME	MANUFACTURER
antislip treatment	bonagrip	bonasystems italia

caution:

1. Do not use these treatments on Lapped or Polished surfaces;
2. Before the doing the treatment contact Lea's Customer Service;
3. It is advisable to carry out the treatments through specialized companies.

POLISHED products can reach a grade of **R9** (test DIN51130) with special laser treatments that may be carried out only on materials that have not been laid: for this reason the request for R9 on Polished products must be specified at the time of the order in the sales department.

Such laser treatments can be also be carried out on **LAPPED** surfaces (after making a verification with LEA CERAMICHE Customer Service).

Useful contacts pag. 424

The manual "cleaning and maintenance" is available on the website
www.ceramichelea.com

INFORMATIONS SUR LE NETTOYAGE ET L'ENTRETIEN

Avant de nettoyer une surface carrelée, il est préférable de:

1. Vérifier la **résistance chimique** des carreaux posés sur le catalogue général;
2. Faire un test avant emploi en versant le nettoyeur directement sur les carreaux installés et en le laissant agir aussi longtemps que la durée prévue sur le chantier;
3. S'assurer que les nettoyeurs **ne contiennent** ni acide fluorhydrique ni aucun de ses dérivés, car ces substances particulières entament tous les produits céramiques.

Veillez trouver ci-après quelques instructions pour bien effectuer les nettoyages de fin de chantier (« après pose »), quotidiens, extraordinaires, pour éliminer les cires et les additifs de cirage et pour réaliser toute opération d'entretien extraordinaire.

Nettoyage « après pose »

1. Le nettoyage « après pose » sert à enlever les résidus de mortier, de ciment, de chaux et de ciment-joint. Il est obligatoire à la fin du chantier, aussi bien pour les carreaux émaillés que pour les carreaux non émaillés.
2. Un mauvais nettoyage « après pose », voire même l'absence de nettoyage, entraîne souvent la formation d'auréoles qui compromettent la propreté du revêtement de sol, même après un bon nettoyage quotidien.
3. Chaque fois que possible, notamment pour les surfaces moyennes/grandes, il est recommandé d'avoir recours à une monobrosse munie des disques souples (blancs ou beige).
4. Nettoyage ciments-joints mélangés avec de l'eau
Nettoyage avec des nettoyeurs spéciaux à base d'acides tamponnés et dilués. Veuillez trouver dans le tableau ci-après quelques noms de produits facilement trouvables dans le commerce.

RÉSIDU À ENLEVER	TYPE DE NETTOYANT	NOM DES NETTOYANTS	FABRICANT
ciments-joints ciment chaux	à base d'acides tamponnés	keranet	mapei
		cement remover	faberchimica
		deterdek	fila
		trek	kiter
		zementschleierentferner	lithofin
		hmk r63	hmk
		solvacid	geal
		bonaclean / bclean	bonasystems italia
bonadecon / bdecon (*)	bonasystems italia		

Sauf indication contraire de LEA CERAMICHE, suivre avec soin le mode d'emploi signalé par le fabricant sur l'emballage.

(*) Spécifique pour produits qui ne sont pas résistants aux acides

Instructions de nettoyage «après pose»:

1. Nettoyer 4-5 jours après l'exécution des joints (le mortier doit durcir) et avant 10 jours maximum. Après ce délai, le nettoyage peut demander beaucoup plus d'efforts.
2. Mouiller le revêtement de sol avant les opérations de nettoyage. Ainsi l'eau imprègne les joints et atténue le contact avec les nettoyeurs.
3. Laisser agir les nettoyeurs peu de temps et bien rincer à l'eau dès que possible.
4. Ne pas faire le nettoyage si les surfaces carrelées sont très chaudes (par ex. exposées au soleil pendant les mois les plus chauds), car la chaleur renforce l'action agressive des produits chimiques. En été, il doit se faire aux heures fraîches de la journée.
5. Faire toujours des tests avant emploi (sur un carreau non posé), notamment sur les produits Rodés ou Polis.

5. Nettoyage des joints epoxy, bi-composant et réactif

Nettoyer immédiatement les résidus de manière soignée en se conformant aux indications fournies par le fabricant car ce type de coulis durcit rapidement, même en quelques minutes. Suivez attentivement les indications de nettoyage indiqué par le fabricant de joint utilisé et vérifiez son efficacité (même rétroéclairage) avec un nettoyage préventif avant de jointoyer la totalité du sol / mur.

6. Carreaux antidérapants

Les carreaux « antislip » à base de structures rugueuses et/ou structurées se nettoient évidemment moins facilement. Il est dès lors recommandé d'effectuer le nettoyage « après pose » de façon rapide et minutieuse et d'utiliser, si possible, une monobrosse à disques blancs ou beige.

Nettoyage extraordinaire

Il sert à éliminer les taches ou les résidus particulièrement anciens ou tenaces. Faire toujours des tests avant emploi (sur un carreau non posé), notamment sur les produits **Rodés** et **Polis**. Veuillez trouver dans le tableau ci-après des nettoyeurs efficaces selon le type de tache.

RÉSIDU À ENLEVER	TYPE DE NETTOYANT	NOM DES NETTOYANTS	FABRICANT
graisses dépôts de poussières laissées par le piétinement grands nettoyages	alcalins universels (1)	ps87	fila
		intensivreiniger	lithofin
		hmk r55	hmk
		taski r20-strip	johnsondiversey
		bonadecon / bdecon	bonasystems italia
		deterflash	geal
café Coca-Cola jus de fruits	alcalins universels (1)	coloured stain remover	faberchimica
		ps87	fila
		super deterjet	geal
		Eau de Javel	fabricants diverse
vin	oxydant	oxidant	faberchimica
		Eau de Javel	fabricants diverse
dépôts calcaires	acide (1)	viakal	procter & gamble
rouille	acide (1)	acide muriatique dilué	fabricants diverse
encres feutre	à base de solvant	diluant nitro-cellulosique, essence de térébenthine	fabricants diverse
		coloured stain remover	faberchimica
pneus traces de caoutchouc de métaux de crayon	pâte abrasive (1)	vim clorex (2)	guaber
		polishing cream (2)	faberchimica
		strong remover (3)	faberchimica
		detergum (3)	zep italia
saleté des joints	spécifique	fuganet	fila
		fugenreiniger	lithofin

(1) Faire des tests avant emploi sur les produits Rodés et Polis

(2) Recommandé pour les produits Rodés et Polis

(3) Ne pas utiliser sur les produits Rodés, utiliser sur les produits polis en faisant très attention

Sauf indication contraire de LEA CERAMICHE, suivre avec soin le mode d'emploi signalé par le fabricant sur l'emballage.

INFORMATIONS SUR LE NETTOYAGE ET L'ENTRETIEN

Nettoyage quotidien / ordinaire

Utiliser de l'eau chaude et un chiffon en microfibre de bonne qualité, type MAGICCLEAN de **Bonasystems Italia**. De temps en temps, tous les 10-20 jours par ex., et selon l'état du sol, utiliser des détergents neutres très dilués dans de l'eau chaude qui ne contiennent pas de cires et ne laissent pas de tâches brillantes. En fin de lavage, rincer toujours à l'eau et à l'aide d'un chiffon en microfibre de bonne qualité.

TYPE D'OPERATION	TYPE DE NETTOYAGE	NOM DES NETTOYANTS	FABRICANT
nettoyages quotidiens	neutre	floor cleaner	faberchimica
		fila cleaner	fila
		pfleregereiniger	lithofin
		hmk p15	hmk
		bonamain + / bmain +	bonasystems italia
		bonatitania clean / bitania clean	bonasystems italia
		belgres	geal

Sauf indication contraire de LEA CERAMICHE, suivre avec soin le mode d'emploi signalé par le fabricant sur l'emballage.

Nettoyage décors

- utiliser des détergents NEUTRES et dilués.
- NE SURTOUT PAS UTILISER**
- Agents cirants et/ou agents d'imprégnation
- Des détergents acides ou alcalins
- Des produits abrasifs
- Des brosses ou des éponges abrasives.

Élimination des films brillants

Les nettoyants ordinaires disponibles dans le commerce contiennent souvent des cires ou des additifs de cirage qui, lavage après lavage, déposent sur le revêtement de sol des **films brillants** qui entraînent la formation d'auréoles difficiles à éliminer. Des films de ce genre peuvent aussi être occasionnés par certains mortiers. Si des simples boissons, comme le Coca-Cola, le vin, l'eau, etc., sont renversées sur le sol, ce film brillant part et les carreaux reprennent leur **aspect original** plus mat. À côté des carreaux plus brillants, les zones sans cire ont l'air d'être des sortes d'auréoles mates, alors qu'en fait, ce sont les seules parties propres du revêtement de sol. Dans ce cas, il faut :

1. avant toute chose, éliminer le film brillant sur l'ensemble du revêtement de sol (voir tableau ci-après) ;
2. ensuite, pour les nettoyages quotidiens, utiliser des nettoyants neutres qui ne contiennent ni cire ni additif de cirage (voir paragraphe précédent « nettoyages quotidiens/ordinaires »).

RÉSIDU À ENLEVER	TYPE DE NETTOYANT	NOM DES NETTOYANTS	FABRICANT
films brillants	légèrement acide	tile cleaner pur (*)	faberchimica

(*) Ne pas suivre le mode d'emploi signalé sur l'emballage, mais utiliser le nettoyant pur, laisser agir 5-10 minutes, frotter avec des disques tampons doux (blanc, jaune) et bien rincer à l'eau.

Nes pas utiliser de cires sur le grès cérame LEA CERAMICHE.

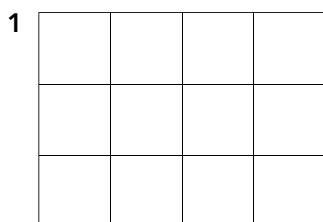

Sol original.

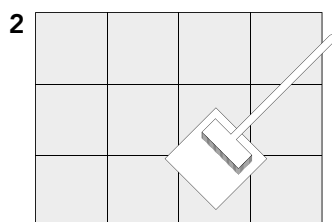

Après un nettoyage avec détergents contenant de la cire.

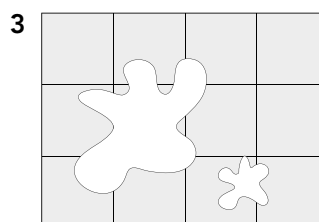

Certains aliments (Coca-Cola, vin, eau, etc.) peuvent enlever la patine brillante. La surface originelle est plus opaque.

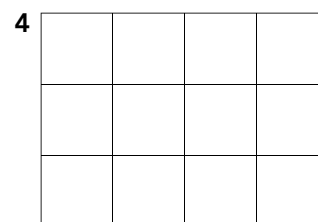

Retirer la patine à l'aide d'un détergent (Tile Cleaner pur de Faber) et utiliser chaque jour un détergent sans cire.

Protection joints

NOM DU PRODUIT	FABRICANT
fugaproof	fila
kf fugenschutz	lithofin

Sauf indication contraire de LEA CERAMICHE, suivre avec soin le mode d'emploi signalé par le fabricant sur l'emballage.

Traitements antidérapantes

La résistance au glissement des carrelages posés (aussi bien des carreaux émaillés que des carreaux non émaillés) peut être améliorée avec des produits spécifiques (voir tableau).

Avant d'appliquer le produit sur le revêtement de sol, faire toujours des tests sur les carreaux non posés pour déterminer les temps de pose plus indiqués. Si d'un côté, les longs temps de pose augmentent le coefficient de frottement, de l'autre, ils ont tendance à décolorer un peu les carreaux et à les salir plus vite.

TYPE D'OPÉRATION	NOM DU PRODUIT	FABRICANT
traitement antidérapante	bonagrip	bonasystems italia

attention:

1. Ne pas faire ces traitements sur les surfaces Rodées ou Polies ;
2. Avant le traitement, contacter le Service Clients Lea ;
3. Il est recommandé de confier le traitement à des entreprises spécialisées.

Les produits **POLIS** peuvent atteindre un niveau d'adhérence **R9** (essai DIN 51130) par le biais de traitements laser ; ceux-ci ne peuvent être effectués que sur les produits non posés. Pour les carreaux Polis, le client est donc tenu de spécifier le niveau R9 au service commercial lors de la commande. Ces traitements laser peuvent aussi être effectués sur les surfaces **RODÉES** (après vérification auprès du Service Clients LEA CERAMICHE).

Quelques noms utiles pag. 424

Le manuel technique « entretien et maintenance » est disponible sur le site internet www.ceramichelea.it

INFORMATIONEN ZUR REINIGUNG UND PFLEGE

Vor der Reinigung einer gefliesten Fläche wird folgendes empfohlen:

1. Im Hauptkatalog die **Chemikalienbeständigkeit** der verlegten Fliesen prüfen;
2. Einen Vortest direkt auf den verlegten Fliesen vornehmen, indem das zu verwendende Reinigungsmittel über den gleichen Zeitraum wie in der Baustelle mit den Fliesen in Kontakt gebracht wird;
3. Sicherstellen, dass die zu verwendenden Reinigungsmittel **keine** Fluorwasserstoffsäure und/oder ihre Derivate enthalten, da diese Substanzen durch ihre Besonderheit **alle** keramischen Produkte angreifen.

Es folgen einige Angaben zur täglichen, außergewöhnlichen Reinigung am Ende der Bauarbeiten („nach dem Verlegen“), um Wachs und glänzende Schichten zu entfernen und um eventuelle besondere Wartung auszuführen.

Reinigung „nach dem verlegen“

1. Die Reinigung „nach dem Verlegen“ dient zur Entfernung der Spachtelrückstände, Zementrückstände und Kalkrückstände. Sie ist am Ende der Bauarbeiten für die glasierten und unglasierten Fliesen obligatorisch.
2. Eine schlecht ausgeführte oder eventuell gar nicht ausgeführte Reinigung „nach dem Verlegen“ ist oft die Ursache von Schatten, die trotz einer täglichen Reinigung die Ursache eines nicht sauberen Bodens sind.
3. Wenn möglich – vor allem bei mittel-großen Oberflächen – empfehlen wir die Anwendung eines Einbürstengeräts mit passenden Scheiben weich (weiß oder beige).
4. reinigung von mit wasser gemischten mörtel
Diese wird mit speziellen Reinigungsmitteln mit gepufferten und verdünnten Säuren ausgeführt. Einige dieser, die im Handel leicht erhältlich sind, sind in der folgenden Tabelle aufgeführt.

ZU ENTFERNENDER REST	REINIGUNGSMITTEL	NAME REINIGUNGSMITTEL	HERSTELLER
Mörtel Zementschlamm Zement Kalk	Mit gepufferten Säuren	keranet	mapei
		cement remover	faberchimica
		deterdek	fila
		trek	kiter
		zementschleierentferner	lithofin
		hmk r63	hmk
		solvacid	geal
		bonaclean / bclean	bonasystems italia
		bonadecon / bdecon (*)	bonasystems italia

Außer bei anders lautenden Angaben von LEA CERAMICHE, werden die Gebrauchsanweisungen der Produkthersteller befolgt.

(*) Für nicht säurebeständige Produkte geeignet

Anleitungen für die Reinigung „nach dem Verlegen“:

1. Die Reinigung 4-5 Tage nach der Verlegung (die Fugenmasse muss aushärten) und nicht nach 10 Tagen ausführen. Über diesen Zeitraum hinaus kann die Reinigung sehr schwierig werden.
2. Den Boden vor der Reinigung mit Wasser benetzen. Auf diese Weise werden die Verfugungen mit Wasser benetzt und der Kontakt mit den Reinigungsmitteln reduziert.
3. Die Reinigungsmittel über eine begrenzte Zeit einwirken lassen und sobald wie möglich mit Wasser spülen.
4. Die Reinigung darf nicht ausgeführt werden, wenn die gefliesten Flächen sehr heiß sind (z.B. im Sommer der Sonne ausgesetzt), da die Wirkung der chemischen Substanzen aggressiver ist. Im Sommer wird sie in den kühlen Stunden des Tags ausgeführt.
5. Vor der Anwendung immer Tests vornehmen (auf einer nicht verlegten Fliese), insbesondere bei geläppten oder polierten Produkten.

5. Reinigung von epoxy-, bi-komponent und aktiven spachtelmassen

In diesen Fällen müssen die Stuckrückstände sofort und sehr sorgfältig unter Beachtung der Angaben des Herstellers erfolgen, weil diese Stucke u.U. sehr schnell in wenigen Minuten härten. Die angegebene Reinigungshinweis vom Hersteller der verwendete Fugenmasse sorgfältig befolgen. Vor dem Verfugen des gesamten Belag (Boden u/o Wand), die Wirkung der Reinigungsempfehlung (auch im Gegenlicht!) mit einem Vor-Test Reinigung überprüfen.

6. Rutschfeste fliesen

Aufgrund ihrer Beschaffenheit sind die rutschfesten, rauen oder strukturierten Oberflächen etwas schwieriger zu reinigen. Aus diesem Grunde ist die Reinigung sehr wichtig. Für eine schnellere Reinigung wird der Einsatz einer Einscheibenmaschine mit einer weissen oder beige Scheibe empfohlen.

Sonderreinigung

Sie wird ausgeführt, um besonders alte oder hartnäckige Flecken oder Reste zu entfernen. Vor der Anwendung immer Tests vornehmen (auf einer nicht verlegten Fliese), insbesondere bei **geläppten** und **polierten** Fliesen. In der unten aufgeführten Tabelle sind wirksame Reinigungsmittel je nach Fleckenart angegeben.

ZU ENTFERNENDER REST	ART DES REINIGUNGSMITTELS	NAME REINIGUNGSMITTEL	HERSTELLER
Fette Trittsaub Grundreinigung	Polyfunktionell, mit Alkalibasis (1)	ps87	fila
		intensivreiniger	lithofin
		hmk r55	hmk
		taski r20-strip	johnsondiversey
		bonadecon / bdecon	bonasystems italia
		deterflash	geal
Kaffee Coca Cola Obstsäfte	Polyfunktionell, mit Alkalibasis (1)	coloured stain remover	faberchimica
		ps87	fila
		super deterjet	geal
		Bleichmittel	verschiedene hersteller
Wein	Oxydierend	oxidant	faberchimica
		Bleichmittel	verschiedene hersteller
Kalkrückstände	Mit Säurebasis (1)	viakal	procter & gamble
Rost	Mit Säurebasis (1)	verdünnte salzsäure	verschiedene hersteller
Tinten Filzstift	Mit Lösungsmittel	Nitroverdünner, Terpentin	verschiedene hersteller
		coloured stain remover	faberchimica
Reifen Gummiflecken Metall Bleistift	scheuermittel (1)	vim clorex (2)	guaber
		polishing cream (2)	faberchimica
		strong remover (3)	faberchimica
		detergum (3)	zep italia
Fugenschmutz	Spezifisch	fuganet	fila
		fugenreiniger	lithofin

(1) Vortesten auf geläppten und polierten Materialien

(2) Für geläppte und polierte Materialien

(3) Nicht auf geläppten Produkten verwenden, sehr vorsichtig auf polierten Materialien verwenden.

Außer bei anders lautenden Angaben von LEA CERAMICHE, die von den Herstellern angegebenen Gebrauchsanweisungen befolgen.

INFORMATIONEN ZUR REINIGUNG UND PFLEGE

Tägliche / regelmäßige reinigung

Warmes Wasser und ein hochwertiges Mikrofasertuch vom Typ MAGICCLEAN von **Bonasystems Italia** verwenden. Ab und zu, zum Beispiel alle 10-20 Tage, je nach Zustand des Fußbodenbelags, neutrale in warmen Wasser verdünnte Reinigungsmittel verwenden, die wachsfrei sind und keine glänzenden Schmierfilme hinterlassen. Nach dem Reinigen immer mit Wasser nachspülen und dafür ein zweites hochwertiges Mikrofasertuch verwenden.

VORGANGSART	ART DES REINIGUNGSMITTELS	NAME REINIGUNGSMITTEL	HERSTELLER
Tägliche Reinigung	Neutral	floor cleaner	faberchimica
		fila cleaner	fila
		pflegereiniger	lithofin
		hmk p15	hmk
		bonamain + / bmain +	bonasystems italia
		bonatitania clean / btitania clean	bonasystems italia
		belgres	geal

Außer bei anders lautender Angabe durch LEA CERAMICHE, die Gebrauchsanleitungen der Hersteller befolgen.

Reinigung des fliesendekors

- Verwenden Sie ausschließlich NEUTRALE und verdünnte Reinigungsmittel.
- VERWENDEN SIE AUF KEINEN FALL**
- Wachs- und/oder Imprägniermittel
- Ätzende oder alkalische Reinigungsmittel
- Scheuerpasten- und Pulver
- Grobe Bürsten oder abrasive Schwämme.

Entfernen von glänzenden schichten

In den normalen handelsüblichen Reinigungsmitteln sind manchmal Wachse oder glänzende Zusätze enthalten, die nach jeder Reinigung **glänzende** Schichten auf dem Boden hinterlassen, die hartnäckige Streifen verursachen. Schichten dieser Art können auch von einiger Fugenmassen hinterlassen werden. Einfache Lebensmittel wie Coca Cola, Wein, Wasser usw. entfernen durch Fallen auf den Boden diese glänzende Schicht und bringen den matten **Originalzustand** der Fliesen wieder zum Erscheinen. Auf dem glänzenden Teil des Bodens erscheinen die Bereiche ohne Wachs als matte Schatten, eigentlich handelt es sich um die einzigen sauberen Bereiche des Bodens. In diesen Fällen muss man:

1. Zuerst die glänzende Schicht vom ganzen Boden entfernen (siehe folgende Tabelle);
2. Dann zur täglichen Reinigung neutrale Reinigungsmittel verwenden, die keine Wachse oder glänzende Zusätze enthalten (siehe vorheriger Abschnitt „tägliche/regelmäßige Reinigung“).

ZU ENTFERNENDER REST	ART DES REINIGUNGSMITTELS	NAME REINIGUNGSMITTEL	HERSTELLER
Glänzende Schichten	Leicht sauer	tile cleaner pur (*)	faberchimica

(*) Die Angaben auf der Verpackung nicht befolgen, sondern das Reinigungsmittel pur anwenden, 5-10 Minuten einwirken lassen, mit weichen Kissen abreiben (weiß, gelb) und gut mit Wasser abspülen.

Keine Wachse auf Feinsteinzeug von LEA CERAMICHE verwenden.

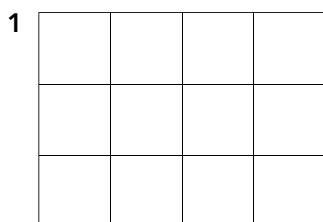

Originalfußboden.

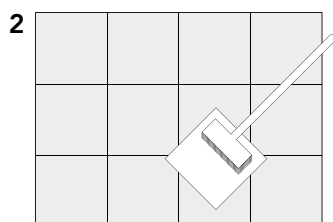

Nach der Reinigung mit wachshaltigen Reinigungsmitteln.

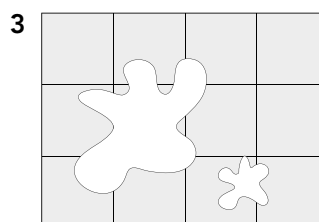

Normale Lebensmittel (Coca-Cola, Wein, Wasser usw...) können die glänzende Patina entfernen. Die Originaloberfläche ist matter.

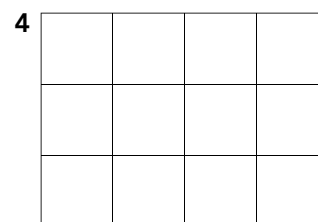

Die Patina sollte mit Reinigungsmittel entfernt werden (Tile cleaner pur von Faber) und für die tägliche Reinigung sollte ein wachsfreies Reinigungsmittel verwendet werden.

Fugenschutzmittel

PRODUKTNAME	HERSTELLER
fugaproof	fila
kf fugenschutz	lithofin

Außer bei anders lautender Angabe der LEA CERAMICHE die Gebrauchsanleitungen der Hersteller befolgen.

Rutschfeste behandlung

Die Rutschfestigkeit der verlegten Böden (glasierte sowie unglasierte Fliesen) kann durch Anwendung spezifischer Produkte erhöht werden (siehe Tabelle). Bevor das Produkt auf dem Boden aufgetragen wird, werden Vortests auf nicht verlegten Fliesen vorgenommen, um die geeignete Kontaktzeit zu finden. Wenn längere Zeiten auf der einen Seite die Rutschfestigkeit erhöhen, neigen sie auf der anderen Seite dazu, die Farben der Fliesen zu bleichen und sie etwas schmutzempfindlicher zu machen.

VORGANG	PRODUKTNAME	HERSTELLER
rutschfestigkeits-Behandlung	bonagrip	bonasystems italia

Achtung:

1. Diese Behandlungen nicht auf geläppten oder polierten Oberflächen verwenden;
2. Vor der Behandlung den Kundenservice Lea fragen;
3. Wir empfehlen, die Behandlung durch spezialisierte Firmen auszuführen.

Die **POLIERTEN** Produkte können den Grad **R9** (Test DIN51130) mit geeigneten Laserbehandlungen erreichen, die nur bei nicht verlegtem Material ausgeführt werden können: Somit muss die Anforderung des Grads R9 für polierte Produkte im Auftrag an die Verkaufsabteilung angegeben werden. Diese Laserbehandlungen können auch auf **GELÄPPTEN** Oberflächen ausgeführt werden (nach der Prüfung des Kundenservice von LEA CERAMICHE).

Nützliche adressen pag. 424

Das technische Handbuch "Reinigung und Verbrauch" finden Sie jetzt auf unsere Web Site www.ceramichelea.com

RIFERIMENTI UTILI

USEFUL CONTACTS

QUELQUES NOMS UTILES

NÜTZLICHE ADRESSEN

MAPEI SPA,

via Cafiero 22, 20158 Milano – ITALY
Tel. +39 02 37673 – www.mapei.it

FABERCHIMICA SRL,

via G. Ceresani 10 – località Campo d'Olmo 60044 Fabriano (AN) – ITALY
Tel. +39 0732 627178 – www.faberchimica.com

FILA INDUSTRIA CHIMICA SPA,

via Garibaldi 32, 35018 S. Martino dei Lupari (PD) - ITALY
Tel. +39 049 9467300 – www.filachim.it

ZEP ITALIA SRL,

via Nettunese Km 25,000 – 04011 Aprilia (LT) – ITALY
Tel. +39 06 926691 – www.zepitalia.it

JOHNSONDIVERSEY,

via Meucci, 40 – 20128 Milano - ITALY
Tel. +39 0373 2051 – www.johnsondiverse.com

KITER SRL,

via Assiano 7/B – 20019 Settimo Milanese (MI) – ITALY
Tel. +39 02 3285220 – www.kiter.it

GEAL SRL,

via Settola 121 - 51031 Agliana (Pistoia) - ITALY
Tel. +39 0574 750365 - www.geal-gres.it

FEDERCHEMICALS SRL,

via Borsi 2 - 25100 Brescia - ITALY
Tel. +39 030 3385578 - www.federchemicals.it

LITHOFIN-PRODUCTE GMBH,

Postfach 1134, D-73236 Wendlingen (D)
Service – Tel. 0049 07024/940320 – www.lithofin.de
Vertrieb für Österreich: CT-Austria Ges.m.b.H. A-1230 Wien Tel. 0043 01 8673434

HMK - MÖLLER-CHEMIE BENELUX GMBH

– Linge 4 NL-2105 WB Heemstede (NL)
Tel. 0031 0252-220222 – www.moellerchemie.de

BONASYSTEMS ITALIA SRL,

via Borgo Santa Chiara 29 - 30020 Torre di Mosto (Venezia) - ITALY
Tel. +39 0421 325691 - www.bonasytemsitalia.it

IMBALLI

424/425

PACKING

EMBALLAGE

VERPACKUNG

ABSOLUTE SLIMTECH

ARTICOLO	SCATOLA					PALLET		
	cm	inch	pz.	mq	kg	scat.	mq	kg
fondo 5plus	100x300	39"x118"	1	3,00	34,5	13 pz/pl	39,0	448,5
fondo 5plus	100x100	39"x39"	2	2,00	23,0	25	50,0	575,0
fondo 5plus	33x100	13"x39"	4	1,32	16,0	36	47,5	576,0

BASALTINA STONE PROJECT

ARTICOLO	SCATOLA					PALLET		
	cm	inch	pz.	mq	kg	scat.	mq	kg
fondo	60x120	24"x48"	2	1,44	40,8	15	21,6	612,0
fondo	60x60	24"x24"	4	1,44	35,0	24	34,6	840,0
fondo	30x60	12"x24"	8	1,44	34,9	32	46,1	1116,8
mosaico 1	28,5x28,5	11 ^{1/4} "x11 ^{1/4} "	5	0,41	7,8	48	19,5	372,0
muretto	30x60	12"x24"	4	0,72	15,2	30	21,6	456,0
battiscopa	10x60	4"x24"	12	7,2 m.l.	18,0	55	396,0 m.l.	990,0
gradino plus	35x120	13 ^{3/4} "x48"	2	0,84	23,2	16	13,4	371,2
angolo gradino plus	35x120	13 ^{3/4} "x48"	1	0,42	13,5	16	6,7	216,0
gradino plus	35x60	13 ^{3/4} "x24"	4	0,84	23,2	16	13,4	371,2
angolo gradino plus	35x35	13 ^{3/4} "x13 ^{3/4} "	2	0,25	7,4	36	8,8	266,4
raccordo jolly	1,3x30	1/2"x12"	8	-	0,3	-	-	-
beak	1,3x1,3	1/2"x1/2"	4	-	-	-	-	-

BASALTINA STONE PROJECT SLIMTECH

ARTICOLO	SCATOLA					PALLET		
	cm	inch	pz.	mq	kg	scat.	mq	kg
fondo 3mm	100x300	39"x118"	1	3,00	22,2	20 pz/pl	60,0	444,0
fondo 3plus	100x300	39"x118"	1	3,00	25,4	20 pz/pl	60,0	507,0
fondo 3plus	100x100	39"x39"	3	3,00	24,1	25	75,0	602,5
fondo 3mm	50x100	19 ^{1/2} "x39"	5	2,50	17,8	32	80,0	569,6
fondo 3plus	50x100	19 ^{1/2} "x39"	5	2,50	20,0	32	80,0	640,0
fondo 3plus	50x50	19 ^{1/2} "x19 ^{1/2} "	7	1,75	14,0	48	84,0	672,0
fondo 3mm	4,9x100	2"x39"	10	0,49	4,0	39	19,1	156,0
fondo 3plus	4,9x100	2"x39"	10	0,49	4,2	39	19,1	163,8
mosaico metal	50x100	19 ^{1/2} "x39"	2	1,00	9,9	25	25,0	247,6
mosaico striscia	25x50	10"x19 ^{1/2} "	10	1,25	6,9	60	75,0	414,0
mosaico listello	25x50	10"x19 ^{1/2} "	10	1,25	6,9	60	75,0	414,0
mosaico inox	25x25	10"x10"	10	0,63	4,6	60	37,5	276,0
mosaico satin	25x25	10"x10"	10	0,63	4,6	60	37,5	276,0
mosaico pearl	25x25	10"x10"	10	0,63	4,6	60	37,5	276,0
mosaico quadro	25x25	10"x10"	10	0,63	4,6	60	37,5	276,0
mosaico mattone	25x25	10"x10"	10	0,63	4,6	60	37,5	276,0

IMBALLI

PACKING
EMBALLAGE
VERPACKUNG

BIO LUMBER

ARTICOLO	SCATOLA					PALLET		
	cm	inch	pz.	mq	kg	scat.	mq	kg
fondo	30x120	12"x48"	4	1,44	34,0	18	25,9	612,0
fondo	20x120	8"x48"	5	1,20	27,8	24	28,8	666,0
decoro beehive	20x120	8"x48"	2	0,48	11,5	54	25,9	621,0
decoro cluster mix	20x20	8"x8"	6	0,24	6,0	124	29,8	744,0
battiscopa	10x60	4"x24"	12	7,2 m.l.	18,0	60	432,0 m.l.	1080,0
gradino plus	35x120	13 ^{3/4} "x48"	2	0,84	23,2	16	13,4	371,2
angolo gradino plus	35x120	13 ^{3/4} "x48"	1	0,42	12,0	16	6,7	192,0

BIO PLANK

ARTICOLO	SCATOLA					PALLET		
	cm	inch	pz.	mq	kg	scat.	mq	kg
fondo	20x120	8"x48"	5	1,20	30,6	24	28,8	734,4
decoro fence	20x120	8"x48"	4	0,96	24,5	12	11,5	294,0
battiscopa	10x60	4"x24"	12	7,2 m.l.	18,0	55	396,0 m.l.	990,0
gradino plus	35x120	13 ^{3/4} "x48"	2	0,84	23,2	16	13,4	371,2
angolo gradino plus	35x120	13 ^{3/4} "x48"	1	0,42	12,4	16	6,7	198,4

BIO RECOVER

ARTICOLO	SCATOLA					PALLET		
	cm	inch	pz.	mq	kg	scat.	mq	kg
fondo	20x180	8"x71"	3	1,08	30,0	48	51,8	1440,0
fondo	20x121,5	8"x48"	5	1,22	29,0	24	29,2	696,0
decoro full	20x90	8"x36"	4	0,72	20,0	30	21,6	600,0
decoro pied de poule	20x90	8"x36"	4	0,72	20,0	30	21,6	600,0
decoro frammenti	-	-	6	0,29	9,0	96	27,6	864,0
battiscopa	10x60	4"x24"	12	7,2 m.l.	16,0	56	403,0 m.l.	896,0
gradino plus	35x120	13 ^{3/4} "x48"	2	0,84	23,2	16	13,4	371,2
angolo gradino plus	35x120	13 ^{3/4} "x48"	1	0,42	12,4	16	6,7	198,4

BIO TIMBER

ARTICOLO	SCATOLA					PALLET		
	cm	inch	pz.	mq	kg	scat.	mq	kg
fondo	20x120	8"x48"	5	1,20	30,6	24	28,8	734,4
compass	20x120	8"x48"	2	0,48	12,3	54	25,9	661,5
strip	20x120	8"x48"	2	0,48	12,3	54	25,9	661,5
triangles	20x120	8"x48"	2	0,48	12,3	54	25,9	661,5
mosaico wall	31x31	12 ^{1/4} "x12 ^{1/4} "	4	0,38	9,8	60	23,1	588,0
battiscopa	10x60	4"x24"	12	7,2 m.l.	18,0	56	403,0 m.l.	1008,0
gradino plus	35x120	13 ^{3/4} "x48"	2	0,84	23,2	16	13,4	371,2
angolo gradino plus	35x120	13 ^{3/4} "x48"	1	0,42	12,4	16	6,7	198,4

BLOCK

426/427

ARTICOLO	SCATOLA				PALLET			
	cm	inch	pz.	mq	kg	scat.	mq	kg
fondo	60,4x60,4	24"x24"	4	1,46	33,5	32	46,7	1070,4
fondo	60x60	24"x24"	4	1,44	32,0	32	46,1	1040,0
fascia	10x60,4	4"x24"	12	0,72	15,6	182	36,9	855,4
mosaico 36	30x30	12"x12"	5	0,45	11,0	60	27,0	660,0
battiscopa	10x60,4	4"x24"	16	9,7 m.l.	20,7	48	464,0 m.l.	993,6
gradino step	60,4x60,4	24"x24"	4	1,46	33,5	24	35,0	802,8

CITY

ARTICOLO	SCATOLA				PALLET			
	cm	inch	pz.	mq	kg	scat.	mq	kg
fondo	30x60	12"x24"	4	0,72	15,6	24	17,3	374,4

CLIFFSTONE

ARTICOLO	SCATOLA				PALLET			
	cm	inch	pz.	mq	kg	scat.	mq	kg
fondo	60x120	24"x48"	2	1,44	35,5	15	21,6	532,5
fondo	90x90	36"x36"	2	1,62	40,0	40	64,8	1600,0
fondo	60x90	24"x36"	3	1,62	40,0	30	48,6	1200,0
fondo	60x60	24"x24"	4	1,44	32,5	32	46,1	1040,0
fondo	40x60	16"x24"	4	0,96	21,6	24	23,0	518,4
fondo	30x60	12"x24"	8	1,44	32,5	32	46,1	1040,0
fondo	20x60	8"x24"	8	0,96	21,6	48	46,1	1036,8
muretto	30x60	12"x24"	4	0,72	15,6	30	21,6	468,0
mosaico 16	30x30	12"x12"	5	0,45	10,0	60	27,0	600,0
battiscopa	10x60	4"x24"	12	7,2 m.l.	16,0	60	432,0 m.l.	960,0
gradino plus	35x120	13 ^{3/4} "x48"	2	0,84	23,2	16	13,4	371,2
angolo gradino plus	35x120	13 ^{3/4} "x48"	1	0,42	12,4	16	6,7	198,4
gradino plus	35x60	13 ^{3/4} "x24"	4	0,84	21,2	16	13,4	339,2
angolo gradino plus	35x35	13 ^{3/4} "x13 ^{3/4} "	2	0,25	6,7	36	8,8	241,2

DISTRICT

ARTICOLO	SCATOLA				PALLET			
	cm	inch	pz.	mq	kg	scat.	mq	kg
fondo	90x90	36"x36"	2	1,62	40,0	40	64,8	1600,0
fondo	45x90	18"x36"	3	1,22	30,0	30	36,5	900,0
fondo	60x60	24"x24"	4	1,44	32,5	32	46,1	1040,0
fondo	30x60	12"x24"	8	1,44	32,5	32	46,1	1040,0
decoro metropolitan	60x60	24"x24"	2	0,72	18,0	40	28,8	720,0
decoro guggenheim	60x60	24"x24"	2	0,72	18,0	40	28,8	720,0
decoro moma	60x60	24"x24"	2	0,72	18,0	40	28,8	720,0
decoro central park	30x30	12"x12"	4	0,36	9,0	60	21,6	540,0
decoro bryant park	30x30	12"x12"	4	0,36	9,0	60	21,6	540,0
decoro queens mix	30x30	12"x12"	4	0,36	9,0	60	21,6	540,0
muretto	30x60	12"x24"	4	0,72	15,6	30	21,6	468,0
mosaico 81	30x30	12"x12"	5	0,45	10,0	60	27,0	600,0
mosaico mattone	30x30	12"x12"	5	0,45	10,0	60	27,0	600,0
battiscopa	10x60	4"x24"	12	7,2 m.l.	16,0	60	432,0 m.l.	960,0
gradino plus	35x60	13 ^{3/4} "x24"	4	0,84	21,2	16	13,4	339,2
angolo gradino plus	35x35	13 ^{3/4} "x13 ^{3/4} "	2	0,25	8,0	36	8,8	288,0

IMBALLI

PACKING
EMBALLAGE
VERPACKUNG

DREAMING

ARTICOLO	SCATOLA					PALLET		
	cm	inch	pz.	mq	kg	scat.	mq	kg
fondo	75x75	30"x30"	2	1,13	27,4	42	47,3	1150,8
fondo	73x73	29"x29"	2	1,07	26,3	42	44,8	1105,0
fondo	60x60	24"x24"	4	1,44	32,5	32	46,1	1040,0
fondo	30x60	12"x24"	8	1,44	32,5	32	46,1	1040,0
decoro scraps	60x60	24"x24"	4	1,44	32,5	32	46,1	1040,0
mosaico basic	30x30	12"x12"	4	0,36	8,4	60	21,6	501,0
battiscopa	10x60	4"x24"	12	7,2 m.l.	16,7	60	432,0 m.l.	1002,0
gradino plus	35x60	13 ^{3/4} "x24"	4	0,84	21,4	16	13,4	342,4
angolo gradino plus	35x35	13 ^{3/4} "x13 ^{3/4} "	2	0,25	6,7	36	8,8	241,2
raccordo jolly	1,3x30	1/2"x12"	16	0,06	1,3	322	20,1	412,2
beak jolly	1,3x2	1/2"x3/4"	4	-	0,1	700	0,7	42,0

GOCCIA

ARTICOLO	SCATOLA					PALLET		
	cm	inch	pz.	mq	kg	scat.	mq	kg
tune	13x13	5 ^{1/8} "x5 ^{1/8} "	10	0,17	3,5	80	13,5	280,0
distorsion	13x13	5 ^{1/8} "x5 ^{1/8} "	10	0,17	3,5	80	13,5	280,0
double tune	10x40	4"x16"	4	0,16	3,2	72	11,5	230,4
single tune	10x40	4"x16"	4	0,16	3,2	72	11,5	230,4

GOUACHE-10 SLIMTECH

ARTICOLO	SCATOLA					PALLET		
	cm	inch	pz.	mq	kg	scat.	mq	kg
fondo 3mm	100x300	39"x118"	1	3,00	22,2	20 pz/pl	60,0	444,0
fondo 3plus	100x300	39"x118"	1	3,00	25,4	20 pz/pl	60,0	507,0
fondo 3plus	100x100	39"x39"	3	3,00	24,1	25	75,0	602,5
fondo 3mm	50x100	19 ^{1/2} "x39"	5	2,50	17,8	32	80,0	569,6
fondo 3plus	50x100	19 ^{1/2} "x39"	5	2,50	20,0	32	80,0	640,0
fondo 3plus	50x50	19 ^{1/2} "x19 ^{1/2} "	7	1,75	14,0	48	84,0	672,0
fondo 3plus	4,9x100	2"x39"	10	0,49	4,2	39	19,1	163,8
decoro libeccio	15,4x22,3	6 ^{1/8} "x8 ^{3/4} "	10	0,34	2,8	80	27,5	224,0

LINES SLIMTECH

428 / 429

ARTICOLO	SCATOLA					PALLET		
	cm	inch	pz.	mq	kg	scat.	mq	kg
fondo 3plus	100x300	39"x118"	1	3,00	25,4	20 pz/pl	60,0	507,0

LINK

ARTICOLO	SCATOLA					PALLET		
	cm	inch	pz.	mq	kg	scat.	mq	kg
fondo	30x30	12"x12"	6	0,54	11,3	58	31,3	655,4
fondo bolli sfalsati	20x20	8"x8"	8	0,32	6,8	90	28,8	612,0
fondo borchie - righe	20x20	8"x8"	12	0,48	10,2	90	43,2	918,0

MAKÒ

ARTICOLO	SCATOLA					PALLET		
	cm	inch	pz.	mq	kg	scat.	mq	kg
fondo	60x60	24"x24"	4	1,44	35,0	32	46,1	1120,0
fondo	30x60	12"x24"	8	1,44	34,9	32	46,1	1116,8
fondo	9,7x60	3 ³ / ₄ "x24"	13	0,76	19,2	60	45,4	1152,0
fondo	2x60	3/4"x24"	12	0,14	3,5	100	14,4	348,0
fondo	2x2	3/4"x3/4"	12	-	-	300	1,4	3,0
decoro pin striped	30x60	12"x24"	4	0,72	17,2	24	17,3	412,8
decoro wallflower	30x60	12"x24"	4	0,72	17,2	48	34,6	825,6
decoro tartan	30x60	12"x24"	4	0,72	17,2	48	34,6	825,6
decoro cross	30x60	12"x24"	4	0,72	17,2	30	21,6	516,0
decoro wallpaper	20x60	8"x24"	4	0,48	11,4	60	28,8	686,4
decoro corset	30x30	12"x12"	6	0,54	13,1	35	18,9	457,8
fascia brocade	3x60	1 ³ / ₁₆ "x24"	12	0,22	5,2	100	21,6	516,0
fascia twill	3x60	1 ³ / ₁₆ "x24"	10	0,18	7,5	100	18,0	753,0
battiscopa	10x60	4"x24"	12	7,2 m.l.	18,0	55	396,0 m.l.	990,0
gradino step	60x60	24"x24"	4	1,44	35,0	24	34,6	840,0
beak jolly	1,3x1,3	1/2"x1/2"	4	-	-	-	-	-
raccordo jolly	1,3x30	1/2"x12"	8	-	0,3	-	-	-

MAUK SLIMTECH

ARTICOLO	SCATOLA					PALLET		
	cm	inch	pz.	mq	kg	scat.	mq	kg
cuadra 3plus	57,6	22 ⁵ / ₈ "	6	1,73	15,5	5	8,6	77,5
esa 3plus	38,3	15 ¹ / ₈ "	12	0,77	6,4	20	15,4	127,0
spina 3mm	25,8x13,5x8,7	10 ¹ / ₈ "x5 ³ / ₈ "x3 ³ / ₈ "	15	0,18	1,5	80	14,8	120,0

IMBALLI

PACKING
EMBALLAGE
VERPACKUNG

METROPOLIS

ARTICOLO	SCATOLA			PALLET				
	cm	inch	pz.	mq	kg	scat.	mq	kg
fondo	90x90	36"x36"	2	1,62	40,0	40	64,8	1600,0
fondo	45x90	18"x36"	3	1,22	30,0	30	36,5	900,0
fondo	60x60	24"x24"	4	1,44	32,5	32	46,1	1040,0
fondo	30x60	12"x24"	8	1,44	32,5	32	46,1	1040,0
muretto urban	30x60	12"x24"	4	0,72	15,6	30	21,6	468,0
muretto avenue 3D	30x60	12"x24"	4	0,72	18,2	30	21,6	546,0
bacchetta metal	1,5x60	5/8"x24"	15	0,14	4,5	100	13,5	450,0
battiscopa	10x60	4"x24"	12	7,2 m.l.	18,0	50	360,0 m.l.	900,0
gradino plus	35x60	13 ^{3/4} "x24"	4	0,84	21,2	16	13,4	339,2
angolo gradino plus	35x35	13 ^{3/4} "x13 ^{3/4} "	2	0,25	6,7	36	8,8	241,2

NAIVE SLIMTECH

ARTICOLO	SCATOLA			PALLET				
	cm	inch	pz.	mq	kg	scat.	mq	kg
fondo 5plus	100x300	39"x118"	1	3,00	34,5	13 pz/pl	39,0	448,5
fondo 5plus	100x100	39"x39"	2	2,00	23,0	25 pz/pl	50,0	575,0

NEST SLIMTECH

ARTICOLO	SCATOLA			PALLET				
	cm	inch	pz.	mq	kg	scat.	mq	kg
esagono L 50 (3,5mm)	100x86,6	39"x34 ^{1/8} "	3	1,95	15,6	-	-	-
esagono L 25 (3,5mm)	50x43,2	19 ^{1/2} "x17"	11	1,78	14,5	-	-	-
esagono L 6,2 (3,5mm)	12,5x10,8	5"x4 ^{1/4} "	22	0,22	2,0	-	-	-
ett.+tria. L 50 (3,5mm)	100x86,6	39"x34 ^{1/8} "	3	1,95	15,6	-	-	-
ett.+tria. L 25 (3,5mm)	50x43,2	19 ^{1/2} "x17"	11	1,78	14,5	-	-	-
ett.+tria. L 6,2 (3,5mm)	12,5x10,8	5"x4 ^{1/4} "	22	0,22	2,0	-	-	-
esagono L 50 (5,5mm)	100x86,6	39"x34 ^{1/8} "	2	1,30	16,6	-	-	-
esagono L 25 (5,5mm)	50x43,2	19 ^{1/2} "x17"	7	1,13	14,7	-	-	-
esagono L 6,2 (5,5mm)	12,5x10,8	5"x4 ^{1/4} "	14	0,14	2,1	-	-	-
ett.+tria. L 50 (5,5mm)	100x86,6	39"x34 ^{1/8} "	2	1,30	16,6	-	-	-
ett.+tria. L 25 (5,5mm)	50x43,2	19 ^{1/2} "x17"	7	1,13	14,7	-	-	-
ett.+tria. L 6,2 (5,5mm)	12,5x10,8	5"x4 ^{1/4} "	14	0,14	2,1	-	-	-

NOVA

430/431

ARTICOLO	SCATOLA					PALLET		
	cm	inch	pz.	m ²	kg	scat.	m ²	kg
fondo	60x120	24"x48"	2	1,44	35,5	15	21,6	532,5
fondo	30x120	12"x48"	4	1,44	34,0	18	25,9	612,0
fondo	60x60	24"x24"	4	1,44	32,5	32	46,1	1040,0
fondo	30x60	12"x24"	8	1,44	32,5	32	46,1	1040,0
mosaico gravity	30x60	12"x24"	4	0,72	15,0	40	28,8	600,0
mosaico 3d	28x28	11"x11"	6	0,47	12,0	36	16,9	432,0
mosaico andromeda	20x30	8"x12"	6	0,36	9,0	80	28,8	720,0
bacchetta metal	1,2x60	1/2"x24"	6	0,04	0,3	250	10,8	75,0
gradino plus	35x120	13 ^{3/4} "x48"	2	0,84	23,2	16	13,4	371,2
gradino plus	35x60	13 ^{3/4} "x24"	4	0,84	21,2	16	13,4	339,2
ang. gradino plus	35x120	13 ^{3/4} "x48"	1	0,42	12,4	16	6,7	198,4
ang. gradino plus	35x35	13 ^{3/4} "x13 ^{3/4} "	2	0,25	6,7	36	8,8	241,2
battiscopa	10x60	4"x24"	12	7,2 m.l.	16,0	60	432,0 m.l.	960,0
raccordo jolly	1,3x30	1/2"x12"	16	0,06	1,3	322	20,1	412,2
beak jolly	1,3x2	1/2"x3/4"	4	-	0,1	700	0,7	42,0

OUTDOOR

ARTICOLO	SCATOLA					PALLET		
	cm	inch	pz.	m ²	kg	scat.	m ²	kg
fondo	20x40,4	8"x16"	13	1,05	21,1	54	56,7	1139,4
fondo	20x30,2	8"x12"	20	1,21	24,2	48	58,0	1161,6
fondo	20x20	8"x8"	30	1,20	23,0	45	54,0	1035,0
battiscopa	10x30,2	4"x12"	28	8,5 m.l.	17,0	33	279,0 m.l.	561,0
elemento elle cont.	5x12x30,2	2"x4 ^{3/4} "x12"	8	0,29	8,0	28	8,1	224,0

PIXEL SLIMTECH

ARTICOLO	SCATOLA					PALLET		
	cm	inch	pz.	m ²	kg	scat.	m ²	kg
fondo 3plus	100x300	39"x118"	1	3,00	25,4	20 pz/pl	60,0	507,0
fondo 3plus	50x100	19 ^{1/2} "x39"	5	2,50	20,0	32	80,0	640,0
fondo 3plus	12,5x50	5"x19 ^{1/2} "	15	0,94	7,5	64	60,0	480,0

PROGETTO L14

ARTICOLO	SCATOLA					PALLET		
	cm	inch	pz.	m ²	kg	scat.	m ²	kg
fondo double 24	20x40	8"x16"	21	1,68	25,5	48	80,6	1225,9
fondo mood 24	20x40	8"x16"	21	1,68	28,4	48	80,6	1363,2
fondo mood 14	10x40	4"x16"	18	0,72	12,0	60	43,2	717,0
decoro spy	10x40	4"x16"	6	0,24	3,8	60	14,4	228,0

IMBALLI

PACKING
EMBALLAGE
VERPACKUNG

RE-EVOLUTION SLIMTECH

ARTICOLO	SCATOLA					PALLET		
	cm	inch	pz.	mq	kg	scat.	mq	kg
fondo 3mm	100x300	39"x118"	1	3,00	22,2	20 pz/pl	60,0	444,0
fondo 3plus	100x300	39"x118"	1	3,00	25,4	20 pz/pl	60,0	507,0
fondo 3plus	100x100	39"x39"	3	3,00	24,1	25	75,0	602,5
fondo 3mm	50x100	19 ^{1/2} "x39"	5	2,50	17,8	32	80,0	569,6
fondo 3plus	50x100	19 ^{1/2} "x39"	5	2,50	20,0	32	80,0	640,0
fondo 3plus	50x50	19 ^{1/2} "x19 ^{1/2} "	7	1,75	14,0	48	84,0	672,0
fondo 3plus	4,9x100	2"x39"	10	0,49	4,2	39	19,1	163,8
cornice	5,5x50	2 ^{1/8} "x19 ^{1/2} "	6	0,17	2,4	600	108,9	1584,0
battiscopa	12x50	4 ^{3/4} "x19 ^{1/2} "	6	3,6 m.l.	4,2	110	39,6	462,0

SHADE SLIMTECH

ARTICOLO	SCATOLA					PALLET		
	cm	inch	pz.	mq	kg	scat.	mq	kg
fondo 3mm	100x300	39"x118"	1	3,00	22,2	20 pz/pl	60,0	444,0
fondo 3plus	100x300	39"x118"	1	3,00	25,4	20 pz/pl	60,0	507,0
fondo 3plus	100x100	39"x39"	3	3,00	24,1	25	75,0	602,5
fondo 3mm	50x100	19 ^{1/2} "x39"	5	2,50	17,8	32	80,0	569,6
fondo 3plus	50x100	19 ^{1/2} "x39"	5	2,50	20,0	32	80,0	640,0
fondo 3plus	50x50	19 ^{1/2} "x19 ^{1/2} "	7	1,75	14,0	48	84,0	672,0
fondo 3plus	4,9x100	2"x39"	10	0,49	4,2	39	19,1	163,8

STREETS IN SHADE SLIMTECH

ARTICOLO	SCATOLA					PALLET		
	cm	inch	pz.	mq	kg	scat.	mq	kg
decoro streets 3mm	50x100	19 ^{1/2} "x39"	2	1,00	7,1	30	30,0	213,6

STONECLAY

ARTICOLO	SCATOLA					PALLET		
	cm	inch	pz.	mq	kg	scat.	mq	kg
fondo	60,4x60,4	24"x24"	4	1,46	33,5	32	46,7	1070,4
fondo	60x60	24"x24"	4	1,44	32,5	32	46,1	1040,0
fondo	30x60	12"x24"	8	1,44	32,5	32	46,1	1040,0
fondo	45,2x45,2	18"x18"	7	1,43	30,0	52	74,4	1560,0
mosaico	30x30	12"x12"	5	0,45	9,3	60	27,0	558,0
battiscopa	10x60	4"x24"	12	7,2 m.l.	16,0	60	432 m.l.	960,0
gradino step	60x60	24"x24"	4	1,44	32,0	32	46,1	1024,0

SUNRISE

ARTICOLO	SCATOLA					PALLET		
	cm	inch	pz.	mq	kg	scat.	mq	kg
fondo	20x90,5	8"x36"	6	1,09	24,5	48	52,1	1176,0
battiscopa	10x60,4	4"x24"	16	0,97	20,7	48	464 m.l.	993,6

SYSTEM L2

432/
433

ARTICOLO	SCATOLA			PALLET				
	cm	inch	pz.	mq	kg	scat.	mq	kg
fondo	30x120	12"x48"	2	0,72	33,3	16	11,5	532,0
fondo	45x90	18"x36"	2	0,81	36,2	24	19,4	869,5
fondo	60x60	24"x24"	2	0,72	33,6	32	23,0	1075,2
costa toro	30x60	12"x24"	1	0,18	8,1	100	18,0	812,5
costa toro angolare	30x60	12"x24"	1	0,14	6,1	100	13,5	610,0
costa retta	30x60	12"x24"	1	0,18	8,1	100	18,0	812,5
costa retta angolare	30x60	12"x24"	1	0,14	6,1	100	13,5	610,0
costa toro step	30x60	12"x24"	1	0,18	8,1	100	18,0	812,5
costa retta step	30x60	12"x24"	1	0,18	8,1	100	18,0	812,5
costa toro con gocc.	30x60	12"x24"	1	0,18	8,1	100	18,0	812,5
costa retta con gocc.	30x60	12"x24"	1	0,18	8,1	100	18,0	812,5
griglia	15x60	6"x24"	2	0,18	8,0	100	18,0	800,0
griglia angolare	15x60	6"x24"	2	0,16	7,0	100	15,8	700,0

TECNOQUARTZ

ARTICOLO	SCATOLA			PALLET				
	cm	inch	pz.	mq	kg	scat.	mq	kg
fondo	60x60	24"x24"	4	1,44	36,6	24	34,6	879,4
fondo	40x60	16"x24"	4	0,96	24,6	24	23,0	589,4
fondo	30x60	12"x24"	7	1,26	32,5	32	40,3	1040,0
fondo	20x60	8"x24"	7	0,84	21,2	48	40,3	1017,6
fondo	30x30	12"x12"	12	1,08	27,2	40	43,2	1089,6
fondo	20x30	8"x12"	12	0,72	17,8	60	43,2	1065,6
anticato 14	14,5x14,5	5 ^{3/4} "x5 ^{3/4} "	31	0,65	17,5	64	41,7	1120,0
anticato 7x14	7,1x14,5	2 ^{3/4} "x5 ^{3/4} "	62	0,64	17,5	64	40,9	1120,0
listone link	30x60	12"x24"	4	0,72	17,9	40	28,8	716,0
mosaico anticato 7	29,3x29,3	11 ^{1/2} "x11 ^{1/2} "	5	0,43	10,5	60	25,8	630,0
muretto	30x60	12"x24"	4	0,72	17,9	30	21,6	537,0
battiscopa	8x30	3 ^{1/8} "x12"	22	5,3 m.l.	15,8	77	407,0 m.l.	1219,7
gradino plus	35x60	13 ^{3/4} "x24"	4	0,84	25,6	16	13,4	409,6
ang. gradino plus	35x35	13 ^{3/4} "x13 ^{3/4} "	2	0,25	8,0	36	8,8	288,0
elemento elle continuo	5x15x30	2"x6"x12"	8	0,36	12,1	28	10,1	338,2
raccordo jolly	1,2x30	1/2"x12"	8	0,03	0,3	-	-	-
beak jolly	1,2x1,3	1/2"x1/2"	4	-	-	-	-	-

TIMELESS MARBLE SLIMTECH

ARTICOLO	SCATOLA			PALLET				
	cm	inch	pz.	mq	kg	scat.	mq	kg
fondo 5plus	100x300	39"x118"	1	3,00	34,5	13 pz/pl	39,0	448,5
fondo 5plus	100x100	39"x39"	2	2,00	23,0	25	50,0	575,0
fondo 5plus	50x150	19 ^{1/2} "x59"	2	1,50	17,5	32	48,0	560,0
fondo 5plus	33x100	13"x39"	4	1,32	16,0	36	47,5	576,0

IMBALLI

PACKING
EMBALLAGE
VERPACKUNG

TRAME

ARTICOLO	SCATOLA			PALLET				
	cm	inch	pz.	mq	kg	scat.	mq	kg
fondo	90x90	36"x36"	2	1,62	40,0	40	64,8	1600,0
fondo	30x90	12"x36"	3	0,81	20,0	27	21,9	540,0
fondo gamma 38	39,2x9,7	15 ^{3/8} "x3 ^{3/4} "	20	0,76	19,0	30	22,8	570,0
fondo gamma 66 sx	39,2x16,9	15 ^{3/8} "x6 ^{5/8} "	10	0,66	16,5	40	26,4	660,0
fondo gamma 66 dx	39,2x16,9	15 ^{3/8} "x6 ^{5/8} "	10	0,66	16,5	40	26,4	660,0
fondo listello	45x5	18"x2"	23	0,52	12,8	60	31,1	768,0
fondo esa	33,8x19,5	13 ^{3/8} "x7 ^{5/8} "	20	0,32	8,0	42	13,4	336,0
fondo cuadra	11,2	4 ^{3/8} "	20	0,22	5,5	100	22,0	276,0
mosaico jewel	33,8x29,7	13 ^{3/8} "x11 ^{3/4} "	4	0,41	10,5	36	14,8	378,0
mosaico leaf	34,2x39,5	13 ^{3/8} "x15 ^{1/2} "	4	0,55	13,5	22	12,1	297,0
mosaico cube	39,5x39,8	15 ^{1/2} "x15 ^{1/2} "	5	0,68	17,0	44	29,7	748,0
mosaico arrow	16,9x39,5	6 ^{5/8} "x15 ^{1/2} "	10	0,46	11,5	40	18,4	460,0
battiscopa	8x90	3 ^{1/8} "x36"	9	0,65	16,5	40	25,9	660,0
gradino plus	35x45	13 ^{3/4} "x18"	2	0,25	7,4	36	8,8	266,4
ang. gradino plus	35x45	13 ^{3/4} "x18"	2	0,25	7,4	36	8,8	266,4
ang. sx gradino plus	35x45	13 ^{3/4} "x18"	2	0,25	7,4	36	8,8	266,4
ang. dx gradino plus	35x45	13 ^{3/4} "x18"	2	0,25	7,4	36	8,8	266,4

TYPE 32 SLIMTECH

ARTICOLO	SCATOLA			PALLET				
	cm	inch	pz.	mq	kg	scat.	mq	kg
fondo 5plus	20x200	8"x79"	3	1,20	15,0	40	48,0	600,0

WATERFALL

ARTICOLO	SCATOLA					PALLET		
	cm	inch	pz.	mq	kg	scat.	mq	kg
fondo	60x120	24"x48"	2	1,44	35,5	15	21,6	532,5
fondo	90x90	36"x36"	2	1,62	40,0	40	64,8	1600,0
fondo	45x90	18"x36"	3	1,22	30,0	30	36,5	900,0
fondo	60x60	24"x24"	4	1,44	32,5	32	46,1	1040,0
fondo 10,5 grip	60x60	24"x24"	4	1,44	33,0	32	46,1	1056,0
fondo	30x60	12"x24"	8	1,44	32,5	32	46,1	1040,0
muretto	30x60	12"x24"	4	0,72	15,6	30	21,6	468,0
muretto 3D	30x60	12"x24"	4	0,68	18,2	30	20,5	546,0
brick	30x60	12"x24"	4	0,72	15,6	30	21,6	468,0
mosaico 36	30x30	12"x12"	5	0,45	10,0	60	27,0	600,0
gramma 72	49,8x16,9	19 ^{1/2} "x6 ^{5/8} "	14	1,01	23,0	40	40,3	920,0
gramma 66	39,2x19,5	15 ^{3/8} "x7 ^{5/8} "	10	0,66	16,5	40	26,4	660,0
gramma 16	19,5x9,7	7 ^{5/8} "x3 ^{3/4} "	30	0,48	12,0	48	23,0	576,0
battiscopa	10x60	4"x24"	12	7,2 m.l.	16,0	60	432,0 m.l.	960,0
gradino plus	35x120	13 ^{3/4} "x48"	2	0,84	23,2	16	13,4	371,2
angolo gradino plus	35x120	13 ^{3/4} "x48"	1	0,42	12,4	16	6,7	198,4
gradino plus	35x60	13 ^{3/4} "x24"	4	0,84	21,2	16	13,4	339,2
angolo gradino plus	35x35	13 ^{3/4} "x13 ^{3/4} "	2	0,25	6,7	36	8,8	241,2
costa toro	30x90	12"x36"	1	0,27	12,2	32	8,6	390,4
costa toro angolare	30x90	12"x36"	1	0,23	10,2	32	7,2	326,4
costa retta	30x90	12"x36"	1	0,27	12,2	32	8,6	390,4
costa retta angolare	30x90	12"x36"	1	0,23	10,2	32	7,2	326,4
costa toro step	30x90	12"x36"	1	0,27	12,2	32	8,6	390,4
costa retta step	30x90	12"x36"	1	0,27	12,2	32	8,6	390,4
griglia	15x45	6"x18"	4	0,27	10,0	48	13,0	480,0
griglia angolare	15x45	6"x18"	4	0,23	10,0	48	10,8	480,0

WAVES SLIMTECH

ARTICOLO	SCATOLA					PALLET		
	cm	inch	pz.	mq	kg	scat.	mq	kg
fondo 3plus	100x300	39"x118"	1	3,00	25,4	20 pz/pl	60,0	507,0

WOOD-STOCK SLIMTECH

ARTICOLO	SCATOLA					PALLET		
	cm	inch	pz.	mq	kg	scat.	mq	kg
fondo 5plus	33x300	13"x118"	1	0,99	12,5	39 pz/pl	38,6	487,0
fondo 5plus	20x200	8"x79"	3	1,20	15,0	40	48,0	600,0
fondo 5plus	20x150	8"x59"	3	0,90	11,3	60	54,0	675,0
fondo 5plus	20x100	8"x39"	3	0,60	7,5	60	36,0	450,0

IMBALLI / ARTICOLI / FONDI

PACKING / ITEMS / PLAIN TILES

EMBALLAGE / ARTICLES / FONDS

VERPACKUNG / ARTIKEL / UNIFLIESEN

GRES LAMINATO SLIMTECH

			SCATOLA			PALLET			
formato	serie	spessore	pz./co	mq/co	kg/co	co/pl	mq/pl	kg/pl	
100x300	5plus	slimtech	5,5mm	1	3,00	34,5	13	39,0	448,5
100x300	3plus	slimtech	3,5mm	1	3,00	25,4	20	60,0	507,0
100x300	3mm	slimtech	3mm	1	3,00	22,2	20	60,0	444,0
33x300	5plus	slimtech	5,5mm	1	0,99	12,5	39	38,6	487,0
20x200	5plus	slimtech	5,5mm	3	1,20	15,0	40	48,0	600,0
50x150	5plus	slimtech	5,5mm	2	1,50	17,5	32	48,0	560,0
20x150	5plus	slimtech	5,5mm	3	0,90	11,3	60	54,0	675,0
100x100	5plus	slimtech	5,5mm	2	2,00	23,0	25	50,0	575,0
100x100	3plus	slimtech	3,5mm	3	3,00	24,1	25	75,0	602,5
50x100	3plus	slimtech	3,5mm	5	2,50	20,0	32	80,0	640,0
50x100	3mm	slimtech	3mm	5	2,50	17,8	32	80,0	569,6
33x100	5plus	slimtech	5,5mm	4	1,32	16,0	36	47,5	576,0
20x100	5plus	slimtech	5,5mm	3	0,60	7,5	60	36,0	450,0
4,9x100	3plus	slimtech	3,5mm	10	0,49	4,2	39	19,1	163,8
4,9x100	3mm	slimtech	3mm	10	0,49	4,0	39	19,1	156,0
50x50	3plus	slimtech	3,5mm	7	1,75	14,0	48	84,0	672,0
12,5x50	3plus	slimtech	3,5mm	15	0,94	7,5	64	60,0	480,0

MONOPOROSA IN PASTA BIANCA

			SCATOLA			PALLET			
formato	serie	spessore	pz./co	mq/co	kg/co	co/pl	mq/pl	kg/pl	
13x13	nat	goccia	9mm	10	0,17	3,5			
20x40	nat	progetto L14 double 24	9mm	21	1,68	25,5	48	80,6	1225,9
20x40	nat	progetto L14	9mm	21	1,68	28,4	48	80,6	1363,2
10x40	nat	progetto L14	9mm	18	0,72	11,9	60	43,2	714,0
10x40	nat	goccia	9mm	4	0,16	3,2			

GRES PORCELLANATO

436/
437

		SCATOLA				PALLET			
formato	serie	spessore	pz./co	mq/co	kg/co	co/pl	mq/pl	kg/pl	
60x120	rtt	basaltina	12mm	2	1,44	40,8	15	21,6	612,0
60x120	rtt	waterfall	10,5mm	2	1,44	35,5	15	21,6	532,5
60x120	rtt	cliffstone - nova	10mm	2	1,44	35,5	15	21,6	532,5
30x120	rtt	system L2	20mm	2	0,72	33,3	16	11,5	532,0
30x120	rtt	bio lumber - nova	10mm	4	1,44	34,0	18	25,9	612,0
20x180	rtt	bio recover	12mm	3	1,08	30,0	48	51,8	1440,0
20x121,5	nat	bio recover	10,5mm	5	1,22	29,0	24	29,2	696,0
20x120	rtt	bio plank - bio timber	11mm	5	1,20	30,6	24	28,8	734,4
20x120	rtt	bio lumber	10mm	5	1,20	27,8	24	28,8	666,0
12x120	rtt	bio plank	11mm	6	0,86	22,5	40	34,6	900,0
20x90,5	nat	sunrise	10mm	6	1,09	22,4	48	52,1	1075,2
90x90	rtt	waterfall	10,5mm	2	1,62	40,0	40	64,8	1600,0
90x90	rtt	cliffstone - district - metropolis	11mm	2	1,62	40,0	40	64,8	1600,0
90x90	rtt	trame	11mm	2	1,62	40,0	40	64,8	1600,0
60x90	rtt	cliffstone	10mm	3	1,62	40,0	30	48,6	1200,0
45x90	rtt	district - metropolis	11mm	3	1,22	30,0	30	36,5	900,0
45x90	rtt	waterfall	10,5mm	3	1,22	30,0	30	36,5	900,0
30x90	rtt	trame	11mm	3	0,81	20,0	27	21,9	540,0
75x75	rtt	dreaming	11mm	2	1,13	27,4	42	47,3	1150,8
73x73	rtt	dreaming	11mm	2	1,07	26,3	42	44,8	1105,0
60,4x60,4	nat	block - stoneclay	10mm	4	1,46	33,5	32	46,7	1070,4
60x60	rtt	system L2	20mm	2	0,72	33,6	32	23,0	1075,2
60x60	rtt	tecnoquartz	12mm	4	1,44	36,6	24	34,6	879,4
60x60	rtt	basaltina - makò	11mm	4	1,44	35,0	24	34,6	840,0
60x60	rtt	waterfall	10,5mm	4	1,44	32,5	32	46,1	1040,0
60x60	rtt	block - cliffstone - district dreaming - metropolis - nova stoneclay	10mm	4	1,44	32,5	32	46,1	1040,0
40x60	rtt	tecnoquartz	12mm	4	0,96	24,6	24	23,0	589,4
40x60	rtt	cliffstone	10mm	4	0,96	21,6	24	23,0	518,4
45,2x45,2	nat	stoneclay	9mm	7	1,43	30,0	52	74,4	1560,0
30x60	rtt	tecnoquartz	12mm	7	1,26	32,5	32	40,3	1040,0
30x60	rtt	basaltina - makò	11mm	8	1,44	34,9	32	46,1	1116,8
30x60	rtt	waterfall	10,5mm	8	1,44	32,5	32	46,1	1040,0
30x60	rtt	cliffstone - district - dreaming metropolis - nova - stoneclay	10mm	8	1,44	32,5	32	46,1	1040,0
20x60	rtt	tecnoquartz	12mm	7	0,84	21,2	48	40,3	1017,6
20x60	rtt	cliffstone	10mm	8	0,96	21,6	48	46,1	1036,8
9,7x60	rtt	makò	11mm	13	0,76	19,2	60	45,4	1152,0
20x40,4	nat	outdoor	9mm	13	1,05	21,1	54	56,7	1139,4
30x30	rtt	tecnoquartz	12mm	12	1,08	27,2	40	43,2	1089,6
20x30,2	nat	outdoor	9mm	20	1,21	24,2	48	58,0	1161,6
20x30	rtt	tecnoquartz	12mm	12	0,72	17,8	60	43,2	1065,6
20x20	nat	outdoor	9mm	30	1,20	24,0	45	54,0	1080,0

NOTA RELATIVA AGLI IMBALLI

Tutti i dati relativi gli imballi indicati nel presente catalogo sono da ritenersi puramente indicativi e potrebbero subire variazioni.

NOTA RELATIVA AL PRODOTTO

Tutte le informazioni relative al prodotto possono subire variazioni in ordine a migliorie dello stesso.

INFORMATION REGARDING PACKAGING

All information regarding packaging in this catalogue are considered purely indicative and subject to change.

NOTE INFORMATIVE CONCERNANT LES IMBALLAGES

Les valeurs des emballages déclarées sur ce catalogue sont purement indicatives et elles pourront être modifiées.

KENNZEICHEN FÜR DIE VERPACKUNGSEINHEITEN

Die Angaben dieser Verpackungen sind rein indikativ und können verändert werden.

INFORMATION REGARDING PRODUCT

All product information can be modified in order to improve it.

NOTE INFORMATIVE CONCERNANT LE PRODUIT

Toutes les informations relatives au produit peuvent subir des variations suite à des améliorations de celui-ci.

KENNZEICHEN FÜR DIE PRODUKTE

Alle Produktinformationen können geändert werden, um es zu verbessern.

CONDIZIONI GENERALI DI VENDITA

1) Ambito di applicazione

1.1 Le presenti condizioni generali di vendita ("CGV") si applicheranno a tutte le forniture di piastrelle in ceramica ("Prodotti") che saranno eseguite nei confronti di qualsiasi cliente ("CLIENTE") da una società o divisione del Gruppo Panariagroup Industrie Ceramiche S.p.A. ("VENDITORE") anche se le CGV non verranno di volta in volta espressamente richiamate, menzionate ovvero espressamente accettate dal CLIENTE.

1.2 Accordi in deroga alle presenti CGV saranno efficaci nei confronti di VENDITORE soltanto (i) se contenuti nel "Contratto di Vendita", come definito al successivo paragrafo 3.2, (ii) se contenuti in documenti successivi alla conclusione del Contratto di Vendita ed il cui contenuto sia stato accettato per iscritto da VENDITORE. In ogni caso, anche se presenti deroghe concordate per iscritto, le CGV continueranno ad applicarsi per le parti non espressamente derogate.

1.3 In nessun caso VENDITORE sarà vincolato da eventuali condizioni generali di contratto di CLIENTE, neanche qualora esse siano richiamate o riportate negli ordini o in qualsiasi altra documentazione trasmessa a VENDITORE da CLIENTE. Nessun comportamento di VENDITORE potrà essere interpretato o utilizzato al fine di esprimere tacita accettazione di VENDITORE delle condizioni generali di contratto di CLIENTE.

1.4 In nessun caso, VENDITORE sarà vincolato da atti e/o azioni dei propri agenti, essendo questi ultimi privi del potere di vincolare il VENDITORE.

1.5 Nel caso in cui CLIENTE sia un consumatore, le disposizioni delle presenti CGV non pregiudicheranno i diritti allo stesso spettanti in base alle previsioni di legge relative alle vendite eseguite nei confronti dei consumatori.

2) Prodotti – Modifiche

2.1 Le rappresentazioni e/o immagini riguardanti i Prodotti riportate in siti internet, brochure, cataloghi, listini prezzi o documenti similari di VENDITORE hanno valore indicativo ed illustrativo. Conseguentemente, esse non rappresentano il risultato estetico finale dei Prodotti. Le caratteristiche tecniche e fisiche nonché le qualità dei Prodotti sono riportate unicamente nei manuali tecnici di VENDITORE. Ogni altro documento riportante le caratteristiche tecniche e fisiche nonché le qualità dei Prodotti ha valore puramente indicativo e non sarà vincolante per VENDITORE.

2.2 VENDITORE dichiara che i Prodotti sono conformi alle norme italiane e comunitarie di settore ad essi applicabili. A pena di inefficacia della garanzia di cui all'articolo 7 e di qualsiasi altra garanzia convenzionale e/o legale, ciascun Prodotto dovrà essere utilizzato ed applicato in conformità alle indicazioni di utilizzo di VENDITORE riferite ai Prodotti in questione e riportate nei cataloghi e/o nei manuali tecnici di VENDITORE ovvero diversamente comunicate o rese accessibili da VENDITORE a CLIENTE e, comunque, in conformità alla diligenza richiesta dalla natura dei Prodotti stessi.

2.3 È responsabilità di CLIENTE, prima della conclusione del Contratto di Vendita, accertare che i Prodotti siano idonei allo scopo e/o all'uso specifico per il quale intende acquistarli e, inoltre, accertare che i Prodotti medesimi siano conformi alla normativa applicabile nel luogo in cui CLIENTE intende importarli, distribuirli, venderli o farne qualsiasi uso.

2.4 VENDITORE, anche dopo la conclusione del Contratto di Vendita, potrà apportare ai Prodotti qualsiasi modifica che esso ritenga necessaria o opportuna, purché non ne alteri le caratteristiche essenziali. Qualora VENDITORE esegua modifiche sostanziali ai Prodotti (ad es. modifiche che interessano: le modalità di installazione, le caratteristiche di intercambiabilità dei Prodotti ecc.) oggetto di un Contratto di Vendita (come definito al successivo paragrafo 3.2), VENDITORE comunicherà per iscritto tale modifica a CLIENTE.

2.5 CLIENTE sarà tenuto a rappresentare agli acquirenti dei Prodotti e ai terzi le caratteristiche dei Prodotti nonché le indicazioni d'uso e di applicazione degli stessi, in conformità a quanto rappresentato dai VENDITORE. Fermo restando quanto sopra, CLIENTE sarà esclusivamente responsabile per le dichiarazioni effettuate nei confronti dei terzi in relazione ai Prodotti, alle loro caratteristiche e al loro uso e/o applicazione e dovrà tenere VENDITORE indenne e manlevato da qualsiasi danno eventualmente subito da VENDITORE in relazione a o in connessione con tali dichiarazioni di CLIENTE, nel caso in cui le stesse siano false, incomplete e/o inesatte.

3) Preventivi – Conclusione del Contratto di Vendita - Tolleranze

3.1 I preventivi, verbali o scritti, di VENDITORE non costituiscono proposte contrattuali.

3.2 Il contratto di vendita ("Contratto di Vendita") si perfezionerà attraverso:

- a) la trasmissione della offerta da parte di VENDITORE e l'accettazione scritta di tale offerta da parte di CLIENTE senza alcuna modifica all'offerta stessa; oppure
- b) la trasmissione dell'ordine da parte di CLIENTE e l'accettazione scritta di tale ordine da parte di VENDITORE.

3.3 Ai fini del precedente paragrafo 3.2, lettera a) i seguenti fatti o atti avranno valore di accettazione scritta della offerta di VENDITORE da parte di CLIENTE:

- a) ricezione e accettazione, da parte di VENDITORE, di una lettera di credito procurata da CLIENTE;
- b) ricezione e accettazione, da parte di VENDITORE, di tutto o di parte del prezzo della fornitura;
- c) ricezione, da parte di VENDITORE, di un ordine di acquisto emesso da CLIENTE. In tal caso, qualsiasi previsione dell'ordine di acquisto di CLIENTE che risulti difforme dalle previsioni della offerta di VENDITORE sarà vincolante nei confronti di VENDITORE solo se specificamente accettata per iscritto da quest'ultimo.

3.4 Inoltre, ai fini del precedente paragrafo 3.2, lettera b), nel caso in cui la accettazione di VENDITORE dell'ordine di CLIENTE contenga condizioni differenti rispetto all'ordine formulato da CLIENTE, il Contratto di Vendita si considererà concluso alle condizioni riportate nella conferma d'ordine di VENDITORE, salvo il caso in cui CLIENTE comunichi per iscritto di rifiutare le modifiche riportate nella accettazione dell'ordine di VENDITORE entro 1 (uno) giorno lavorativo dalla ricezione della stessa.

3.5 Le forniture comprenderanno esclusivamente quanto indicato nel Contratto di Vendita.

3.6 CLIENTE riconosce a VENDITORE i margini di tolleranza quantitativa e/o qualitativa rinvenibili dal Contratto di Vendita o dagli usi o dalla prassi del settore dei Prodotti.

4) Imballaggio – Termini di resa – Termini di consegna

4.1 I Prodotti saranno imballati ed approntati per la spedizione secondo i sistemi di protezione generalmente adottati da VENDITORE per i Prodotti in questione in considerazione delle modalità di trasporto convenute. Qualora CLIENTE ritenga necessario l'impiego di imballaggi speciali o di protezioni aggiuntive dovrà farne espressa richiesta a VENDITORE, fermo restando che, in tal caso, saranno a carico di CLIENTE tutti i relativi costi.

4.2 Salvo diversamente previsto nel Contratto di Vendita, i Prodotti saranno consegnati a CLIENTE in conformità alla regola Incoterms® ICC, ultima versione, Ex-Works (EXW) – stabilimento di VENDITORE indicato nel Contratto di Vendita.

CLIENTE autorizza VENDITORE a sottoscrivere, in nome e per conto di CLIENTE, tutti i documenti che debbano essere sottoscritti al momento della presa in carico dei Prodotti presso gli stabilimenti di VENDITORE, come, ad esempio, il CMR.

Nel caso in cui la regola Incoterms® ICC concordata tra le parti preveda che CLIENTE debba curare il trasporto dei Prodotti fuori dall'Italia:

a) in caso di cessione intra-comunitaria, entro 45 (quarantacinque) giorni dalla ricezione dei Prodotti presso gli stabilimenti di CLIENTE, CLIENTE dovrà trasmettere a VENDITORE un originale e una copia del documento di trasporto internazionale CMR o di altro documento di trasporto, sottoscritti a destinazione da CLIENTE ovvero, in assenza del CMR, una dichiarazione di ricezione dei Prodotti, emessa sulla base del form quale Allegato -1- disponibile per il download all'indirizzo www.panariagroup.it;

b) in caso di cessione extra-comunitaria, CLIENTE si impegna a:

- i) presentare la dichiarazione doganale di esportazione (DAU-EX e DAE) ed effettuare l'appuntamento del MRN (Movement Reference Number) presso la dogana del territorio comunitario di uscita dei Prodotti, entro 90 (novanta) giorni dalla data di consegna in Italia dei Prodotti stessi;
- ii) inviare a VENDITORE, entro 90 (novanta) giorni dalla data di consegna, i documenti comprovanti l'esportazione dei Prodotti (dichiarazione di esportazione DAU-EX + DAE + notifica di avvenuta esportazione);
- iii) confermare prontamente per iscritto a VENDITORE l'avvenuta esecuzione delle suddette formalità e a fornirgli ogni ulteriore documento comprovante l'esecuzione delle suddette formalità e l'uscita dei Prodotti dal territorio dell'Unione Europea.

In caso di inadempienza di CLIENTE a quanto pattuito al presente paragrafo 4.2, VENDITORE avrà il diritto di addebitare immediatamente a CLIENTE l'Imposta sul Valore Aggiunto relativa alla fornitura e connessa alla mancata prova del trasporto dei Prodotti in altro Stato Membro della Comunità Europea o mancato appuramento della esportazione. In ogni caso, CLIENTE terrà indenne e manlevato VENDITORE in relazione al pagamento di tutto quanto eventualmente dovuto da VENDITORE nei confronti dell'Amministrazione Finanziaria, a titolo di sanzioni ed interessi o ad altro titolo, in connessione con la fornitura e la mancata prova del trasporto dei Prodotti in altro Stato Membro della Comunità Europea o al mancato appuramento della esportazione.

A tal proposito, VENDITORE potrà: (i) compensare qualsiasi importo dovuto da CLIENTE in base al presente paragrafo 4.2 con eventuali crediti maturati da CLIENTE, a qualsiasi titolo, nei confronti di VENDITORE; ovvero (ii) trattenere definitivamente eventuali somme già ricevute da CLIENTE in relazione a Contratti di Vendita ancora da eseguirsi, effettuando una compensazione fra il debito di CLIENTE in base al presente paragrafo 4.2 e tutti i pagamenti già eseguiti da CLIENTE.

4.3 VENDITORE eseguirà la consegna dei Prodotti entro il termine previsto nel Contratto di Vendita, anche mediante consegne parziali. Il termine di consegna si intenderà in ogni caso non essenziale né perentorio. Salvo il caso di dolo o colpa grave, VENDITORE non sarà tenuto a corrispondere a CLIENTE alcun indennizzo o risarcimento per eventuali danni diretti o indiretti dovuti al ritardo nella consegna. In nessun caso di ritardo nella consegna dei Prodotti CLIENTE avrà il diritto di risolvere il Contratto di Vendita.

4.4 Al momento della ricezione dei Prodotti, CLIENTE avrà l'onere di denunciare danneggiamenti agli imballi e/o eventuali avarie o ammanchi di Prodotti verificatisi durante il trasporto, mediante apposizione di riserva scritta nel documento di trasporto, nonché l'onere di:

- a) far confermare dal vettore, mediante apposita sottoscrizione, l'apposizione della riserva; e
- b) informare immediatamente per iscritto VENDITORE e inviargli copia del suddetto documento entro e non oltre 8 (otto) giorni dalla data di ricezione dei Prodotti.

In caso contrario, VENDITORE non sarà responsabile per eventuali danneggiamenti, perdite o furti occorsi ai Prodotti durante il trasporto, anche qualora lo stesso sia eseguito con rischio in tutto o in parte a carico di VENDITORE.

5) Prezzi – Pagamento – Ritardato pagamento

5.1 I Prodotti verranno forniti ai prezzi concordati tra le parti nel Contratto di Vendita o, qualora il Contratto di Vendita non dovesse menzionare alcun prezzo, ai prezzi riportati nel listino prezzi di VENDITORE in vigore al momento della conclusione del Contratto di Vendita. Salvo diversa indicazione scritta, i prezzi dei Prodotti riportati nei listini, nei preventivi e/o nelle offerte di VENDITORE si intendono in Euro, al netto di IVA e per consegne eseguite in conformità alla regola Incoterms® Ex-Works (EXW), stabilimento di VENDITORE indicato nel Contratto di Vendita, ICC, ultima versione. Pertanto, nel caso in cui venga convenuto un diverso termine di resa, l'importo della fattura verrà modificato di conseguenza, includendo in fattura le spese di trasporto e ogni altro onere connesso con il termine di resa concordato tra le parti per la consegna dei Prodotti.

5.2 Il pagamento dei Prodotti dovrà essere eseguito da CLIENTE con le modalità e nei tempi indicati nel Contratto di Vendita o diversamente concordati per iscritto tra le parti. I pagamenti si considereranno effettuati da CLIENTE solo nel momento in cui il relativo importo sarà stato accreditato sul conto corrente di VENDITORE. Il pagamento dovrà essere effettuato da CLIENTE in Euro ovvero nella valuta del luogo in cui CLIENTE ha la propria sede, a scelta di VENDITORE, in conformità alla valuta che VENDITORE indicherà nella relativa fattura di vendita.

5.3 Nel caso in cui CLIENTE sia in ritardo nell'esecuzione del pagamento, VENDITORE avrà diritto:

- a) al pagamento degli interessi legali di mora, in conformità alla legge applicabile;
- b) di sospendere le consegne ancora da eseguirsi, previa comunicazione scritta a CLIENTE, fino a quando gli importi dovuti e i relativi interessi di mora siano stati integralmente pagati.

5.4 Qualora tali importi e interessi risultino ancora non pagati una volta decorsi 30 (trenta) giorni dalla scadenza data di pagamento concordata, VENDITORE potrà altresì, a propria discrezione,

alternativamente o cumulativamente, e in aggiunta a qualsiasi altro diritto o rimedio allo stesso spettante in base alla legge o alle presenti CGV:

- a) esigere l'immediato pagamento di ogni debito residuo, anche se sia stato convenuto un pagamento a rate o un pagamento dilazionato e/o siano stati emessi e siano in scadenza cambiali tratte, pagherò cambiari, assegni o altri strumenti di pagamento;
 - b) risolvere il Contratto di Vendita in questione e trattenere definitivamente eventuali somme già ricevute in relazione a tale Contratto di Vendita e/o ad altri Contratti di Vendita, effettuando una compensazione fra il debito di CLIENTE e tutti i pagamenti ricevuti;
 - c) eseguire le future consegne dei Prodotti soltanto previo pagamento anticipato in relazione alle forniture ancora da eseguirsi;
 - d) revocare sconti e bonus che siano stati concordati fra le parti anche in relazione a Contratti di Vendita regolarmente eseguiti.
- 5.5 I diritti di cui ai precedenti paragrafi 5.3 e 5.4 potranno essere esercitati in qualsiasi momento da VENDITORE anche nel caso in cui:
- a) CLIENTE sia sottoposto a liquidazione, a procedure concorsuali, fallimentari, di ristrutturazione del debito o ad azioni esecutive; oppure
 - b) la compagnia assicurativa di VENDITORE rifiuti la copertura assicurativa di crediti di VENDITORE nei confronti di CLIENTE; oppure
 - c) CLIENTE versi in uno stato di difficoltà finanziaria - idoneo a determinare un pregiudizio al puntuale adempimento dei propri obblighi di pagamento - risultante, a titolo esemplificativo e non esaustivo, dalla levata di protesti, dalla diminuzione di garanzie concesse e/o dalla mancata prestazione di garanzie promesse, nonché dal verificarsi di qualsiasi insoluto, anche qualora tali circostanze si siano verificate nell'ambito dei rapporti tra CLIENTE ed altri suoi fornitori.
- 5.6 CLIENTE non potrà far valere eventuali inadempimenti di VENDITORE né potrà avviare alcuna azione legale nei confronti dello stesso fino a quando non abbia pagato integralmente a VENDITORE ogni importo allo stesso spettante ai sensi dei paragrafi 5.3 e 5.4.

6) Riserva di Proprietà

6.1 VENDITORE manterrà la proprietà dei Prodotti venduti fino al completo pagamento del loro prezzo da parte di CLIENTE.

Fermo restando quanto sopra, il rischio di perimento dei Prodotti sarà disciplinato dal termine di resa Incoterms® concordato tra le parti per la consegna dei Prodotti.

6.2 In caso di inadempimento o ritardo nell'adempimento dell'obbligo di pagare il prezzo dei Prodotti, fermo restando quanto previsto ai precedenti paragrafi 5.4, 5.5 e 5.6, VENDITORE avrà il diritto di accedere ai locali in cui si trovano i Prodotti, di rientrarne in possesso e di incamerare definitivamente, a titolo di penale, eventuali somme pagate da CLIENTE per i Prodotti in questione.

7) Garanzia

7.1 Fatto salvo quanto previsto ai precedenti paragrafi 2.1, 2.2, 2.4 e 3.6 in relazione alle modifiche ammesse ai Prodotti e alle tolleranze, VENDITORE garantisce a CLIENTE che i Prodotti saranno conformi al Contratto di Vendita, alla classificazione indicata nei manuali tecnici, cataloghi e/o listini prezzi di VENDITORE nonché privi di difetti di fabbricazione. La presente garanzia avrà la durata di 12 (dodici) mesi dalla data di ritiro dei Prodotti dallo stabilimento di VENDITORE, a prescindere dal termine di resa Incoterms® concordato.

7.2 Sono esclusi da qualsiasi garanzia:

- a) le alterazioni cromatiche e le differenze di tonalità dei Prodotti;
- b) i Prodotti classificati nel Contratto di Vendita come di qualità inferiore alla prima scelta ovvero come partite di Prodotti di fine serie venduta in blocco ovvero come partite speciali;
- c) i Prodotti non posati a regola d'arte e/o posati in modo difforme rispetto alle previsioni delle norme di settore applicabili;
- d) i Prodotti applicati su superfici e/o in ambienti diversi da quelli consigliati da VENDITORE;
- e) i Prodotti utilizzati in modo difforme rispetto alle istruzioni e/o indicazioni di VENDITORE incluse nei cataloghi e/o i listini di VENDITORE ovvero in altro modo comunicate a CLIENTE da VENDITORE ivi incluse le indicazioni di cui al precedente paragrafo 2.2;
- f) i Prodotti utilizzati in modo non conforme alla normale diligenza e/o alla tecnica richieste dalla natura dei Prodotti stessi;
- g) l'ingelività del Prodotto, a meno che tale caratteristica del Prodotto non sia stata dichiarata da VENDITORE nel manuale tecnico, in riferimento al Prodotto in questione;
- h) caratteristiche dei Prodotti come risultanti dalla classificazione del materiale ceramico (i) eseguita da parte di organismi di controllo e/o certificazione diversi da quelli di Paesi dell'Unione Europea e/o (ii) effettuata sulla base di criteri che non corrispondano a quelli utilizzati da VENDITORE.

7.3 Fermo quanto previsto al precedente paragrafo 4.4, CLIENTE sarà tenuto ad esaminare i Prodotti nel più breve tempo possibile e, a pena di decadenza dalla presente garanzia, a denunciare per iscritto a VENDITORE, a mezzo fax o email:

- a) difformità relative alla tipologia e/o alla quantità dei Prodotti ricevuti nonché altre difformità palesi dei Prodotti o loro difetti palesi: entro e non oltre 8 (otto) giorni dalla consegna dei Prodotti e, comunque, prima della posa in opera dei Prodotti;
- b) difformità occulte o difetti occulti dei Prodotti: entro e non oltre 8 (otto) giorni dalla scoperta e, comunque, entro il periodo di garanzia.

7.4 VENDITORE avrà il diritto di verificare i Prodotti, o alcuni campioni dei Prodotti, che CLIENTE ritenga essere difformi o difettosi, anche al fine di verificare il rispetto delle prescrizioni relative alla posa in opera degli stessi e/o all'applicazione e/o all'utilizzo dei Prodotti come rinvenibili dalle presenti CGV. A tale proposito, CLIENTE potrà restituire a VENDITORE i Prodotti dallo stesso ritenuti difformi o difettosi soltanto previa autorizzazione scritta di VENDITORE ed a condizione che CLIENTE si faccia integralmente carico delle spese e dei rischi di spedizione. L'autorizzazione al reso dei Prodotti o dei campioni asseritamente difformi o difettosi non costituirà in nessun caso riconoscimento delle difformità o dei difetti da parte di VENDITORE.

7.5 Nel caso in cui i Prodotti siano riconosciuti da VENDITORE come effettivamente difformi o difettosi, CLIENTE, a scelta di VENDITORE, avrà esclusivamente diritto:

- a) alla sostituzione gratuita dei Prodotti difformi o difettosi; oppure
- b) all'esenzione parziale o totale dal pagamento del loro prezzo, a seconda della gravità delle difformità o dei difetti.

7.6 Ai fini del paragrafo 7.5 lettera (a), i Prodotti che debbano essere consegnati in sostituzione di Prodotti difformi o difettosi saranno consegnati a CLIENTE in conformità alla regola Incoterms® 2010 ICC DDP - stabilimento di CLIENTE. I Prodotti che siano stati sostituiti dovranno essere, a scelta di VENDITORE, distrutti o smaltiti da CLIENTE, a spese di quest'ultimo, ovvero restituiti a VENDITORE, a spese di VENDITORE stesso. Per i Prodotti sostituiti che debbano essere distrutti o smaltiti da CLIENTE, CLIENTE si impegna ad inviare a VENDITORE la prova dell'avvenuta distruzione o smaltimento dei Prodotti, unitamente ai documenti giustificativi comprovanti il sostenimento dei costi di distruzione o smaltimento.

7.7 I diritti e rimedi descritti ai precedenti paragrafi 7.5 e 7.6 costituiscono i soli diritti e rimedi in garanzia concessi a CLIENTE. Nella massima misura consentita dalla legge, sono esclusi ulteriori responsabilità o obblighi di VENDITORE in relazione alla fornitura di Prodotti difformi o difettosi, ivi inclusi, a titolo esemplificativo e non esaustivo, responsabilità e obblighi per eventuali danni diretti, indiretti o consequenziali, perdite di profitto, ecc. a cui tale responsabilità si ricollega.

7.8 La presente garanzia sostituisce ed esclude ogni altra garanzia, espressa o implicita, prevista per legge o altrimenti.

8) Forza maggiore

8.1 VENDITORE non sarà in alcun modo responsabile per il mancato o ritardato adempimento di alcuna obbligazione relativa alla fornitura dei Prodotti qualora tale mancato o ritardato adempimento sia dovuto a eventi di forza maggiore come guerre, incendi, terremoti, inondazioni, tsunami, scioperi, difficoltà insorte con la forza lavoro, scarsità o difficoltà di approvvigionamento di materie prime, restrizioni all'uso di energia, sospensione o difficoltà nei trasporti, guasti agli impianti, atti della pubblica autorità o a qualsiasi altra azione o causa che non possa essere ragionevolmente prevista o alla quale VENDITORE non possa ragionevolmente porre rimedio tramite l'ordinaria diligenza.

8.2 In tali eventualità, il termine per l'esecuzione della fornitura verrà esteso per tutto il periodo di durata dell'evento di forza maggiore, fermo restando che, qualora tale evento dovesse impedire l'esecuzione della fornitura per oltre 6 (sei) mesi, CLIENTE avrà il diritto di risolvere il relativo contratto di vendita, mediante invio di lettera raccomandata con ricevuta di ritorno o corriere a VENDITORE, senza alcuna responsabilità o conseguenza per VENDITORE.

9) Invalidità di singole clausole contrattuali

L'invalidità di una disposizione delle presenti CGV non comprometterà la validità delle residue disposizioni che rimarranno pienamente valide e efficaci.

10) Riservatezza

10.1 CLIENTE si impegna a: (i) trattare come riservati tutte le informazioni/dati/disegni/know-how/documentazione trasmessigli da VENDITORE ovvero di cui sia venuto a conoscenza nell'esecuzione dei singoli Contratti di Vendita, indipendentemente dal fatto che tali informazioni siano o meno contrassegnate o identificate come riservate o confidenziali ("Informazioni Riservate"); (ii) non divulgare e non comunicare a terzi, né in tutto né in parte, le Informazioni Riservate senza il preventivo consenso scritto di VENDITORE; (iii) limitare l'utilizzo di tali Informazioni Riservate ed il relativo accesso per scopi relativi all'esecuzione dei singoli Contratti di Vendita; (iv) adottare tutte le misure necessarie al fine di assicurare che i propri dipendenti e i propri collaboratori evitino di divulgare a terzi le Informazioni Riservate o le utilizzino in modo improprio. Le Informazioni Riservate non potranno essere riprodotte senza previo consenso scritto di VENDITORE, e tutte le copie delle stesse saranno immediatamente restituite dietro richiesta di VENDITORE.

10.2 Le previsioni di cui sopra non si applicano alle informazioni che: (i) sono pubbliche o divengono pubbliche non per divulgazione da parte del CLIENTE, dei suoi dipendenti o collaboratori, o (ii) erano in possesso del CLIENTE prima che le ricevesse da VENDITORE o (iii) sono state divulgate da fonti che non sono sottoposte alle restrizioni cui è sottoposto CLIENTE relativamente al loro utilizzo, o (iv) possono essere divulgate a terzi in base ad un'autorizzazione scritta di VENDITORE.

11) Legge applicabile - Risoluzione delle controversie

11.1 Le presenti CGV e tutti i Contratti di Vendita che le parti stipuleranno in base alle presenti CGV saranno regolati dalla Convenzione di Vienna del 1980 sulla vendita internazionale di merci e, nelle materie non coperte da tale Convenzione, dalla legge italiana.

11.2 Qualsiasi controversia relativa alle presenti CGV e/o ai Contratti di Vendita che interverranno sulla base delle stesse sarà decisa in conformità alle seguenti previsioni:

- a) qualora CLIENTE abbia la sua sede legale nell'Unione Europea, in Svizzera, in Norvegia o in Islanda, la controversia sarà assoggettata in via esclusiva alla giurisdizione italiana e, in relazione ad essa, sarà esclusivamente competente il Tribunale di Modena (Italia);
- b) in tutti gli altri casi, la controversia sarà decisa in via esclusiva e definitiva mediante arbitrato, celebrato da un arbitro unico, in conformità al Regolamento di Procedura della Camera Arbitrale di Milano.

L'arbitrato avrà sede, e il lodo arbitrale verrà pronunciato, nella città di Milano (Italia). La lingua dell'arbitrato sarà la lingua inglese.

11.3 È tuttavia concesso, unicamente a favore di VENDITORE, il diritto incondizionato di agire, in qualità di attore, sotto la giurisdizione di CLIENTE innanzi al tribunale competente.

12) Lingua delle CGV

12.1 Il testo delle presenti CGV è redatto sia in lingua italiana che in lingua inglese.

In caso di discrepanza, il testo in lingua italiana prevarrà sul testo in lingua inglese.

Le presenti condizioni generali di vendita sono pubblicate e scaricabili sul sito internet www.panariagroup.it

GENERAL TERMS AND CONDITIONS OF SALE

1) Scope Of Application

- 1.1 These General Terms and Conditions of Sale ("General Conditions") shall apply to any and all supply of ceramic tiles or other ceramic products ("Products") that will be executed to any client ("CLIENT") from any company or division of the Group Panariagroup Industrie Ceramiche S.p.A. ("SELLER"), even if these General Conditions are not expressly referred to, mentioned or expressly accepted by the CLIENT from time to time.
- 1.2 No provisions deviating from these General Conditions shall be binding on SELLER unless (i) included in the "Sale Contract", as defined under paragraph 3.2 below, (ii) included in documents following the Sale Contract and the content of the same has been accepted in writing by SELLER. In any case, even if deviating provisions are agreed upon, these General Conditions shall apply for the parts not expressly disregarded.
- 1.3 In no case shall any general conditions of contract of CLIENT be binding on SELLER, even if mentioned or included in orders or in any other documents transmitted by CLIENT to SELLER. No conduct of SELLER shall be interpreted or used in order to express tacit acceptance of SELLER to the general conditions of contract of CLIENT.
- 1.4 In no case SELLER shall be bound by acts and/or conducts of its agents, being the latter in lack of any power to bind SELLER.
- 1.5 In case CLIENT is a consumer, the provisions of these General Conditions shall not prejudice the rights of CLIENT provided for by the law applicable to sales executed toward consumers.

2) Products – Modifications

- 2.1 Any representation and/or image relating to the Products included in websites, brochures, catalogues, price lists or other similar documents of SELLER is approximate and purely illustrative. As a consequence, such representations and/or images do not represent the final aesthetic result of the Products. Technical and physical characteristics of the Products as well as qualities of the same are described in the technical manuals of SELLER only. Any other document including technical and physical characteristics and qualities of the Products are purely indicative and shall not bind SELLER.
- 2.2 SELLER declares that the Products are compliant with the applicable Italian and European industry standards. Any Products shall be used and applied in accordance with the instructions of use of SELLER included in catalogues and/or technical manuals of SELLER with reference to the Products in question or with the instructions in other way communicated and/or made available by SELLER to CLIENT and, in any case, in accordance with the diligence required by the nature of the Products. Failing to do so, CLIENT will result in the lapse of the warranty and in the unenforceability of the warranty rights under article 7 below or of any other legal or agreed warranty.
- 2.3 It is the responsibility of CLIENT, before executing of the Sale Contract, to make sure that the Products are suitable for their specific purpose and/or intended use and, in addition, that they also comply with the laws and regulations applicable in the place where CLIENT will import, distribute, sell or use them in any way.
- 2.4 SELLER may make any changes to the Products which, without altering their essential features, it deems necessary or convenient, even after execution of the Sale Contract. In case SELLER executes substantial modification to Products (e.g. modifications that will alter: the way of installation, characteristic of interchangeability of the Products, etc.) which are the object of an executed Sale Contract (as defined in paragraph 3.2 below), SELLER shall communicate in writing such modification to CLIENT.
- 2.5 CLIENT shall inform the purchasers of the Products and third parties of the characteristics of the Products and of the instructions of use and of application of the same in accordance with the indication provided by SELLER. Without prejudice to the above, CLIENT shall be the sole responsible and liable for the declarations it will make toward third parties with reference to the Products, their characteristics and their use or application and shall indemnify and hold SELLER harmless and from any damage possibly suffered by SELLER with reference to or in connection to such declarations of CLIENT, in case they result false, incomplete or inaccurate.

3) Quotations – Execution of Sale Contract – Tolerances

- 3.1 Written or verbal quotations issued by SELLER are not to be taken as valid contractual proposals.
- 3.2 The sale contract ("Sale Contract") is executed as follows:
- a) an offer is sent by SELLER to CLIENT and CLIENT then sends its written acceptance of such offer to SELLER, without any modification to the offer itself; or
 - b) a purchase order is sent by CLIENT and SELLER then sends its written acceptance of such order to CLIENT.
- 3.3 For the purposes of paragraph 3.2 letter a) above, the following facts or actions shall constitute the written acceptance of an offer of SELLER by CLIENT:
- a) the receipt by SELLER of a letter of credit sent by CLIENT;
 - b) the receipt by SELLER of all or part of the relevant purchase price;
 - c) the receipt by SELLER of a purchase order of CLIENT. Should this be the case, any order of CLIENT that differs from the provisions of the offer of SELLER shall be binding on SELLER only if and to the extent that SELLER had expressly accepted it in writing.
- 3.4 In addition, for the purposes of paragraph 3.2 letter b) above, in case the acceptance of SELLER includes terms and condition different from those of the order of CLIENT, the Sale Contract shall be deemed to be concluded at the conditions included in the acceptance of SELLER, unless CLIENT notifies SELLER, in writing, not to accept the terms and conditions of the acceptance of SELLER within 1 (one) working day from the receipt of such acceptance.
- 3.5 All supplies of Products will only include what is expressly indicated in Sale Contract.
- 3.6 CLIENT recognizes to SELLER quantity and quality tolerances as resulting from the Sale Contract or from the usage and practices of the sector of the Products.

4) Packing – Delivery term – Delivery time

- 4.1 The Products will be packaged and readied to ship in compliance with the standard protection methods generally adopted by SELLER for the Products in question, in consideration of the agreed mode of transport. CLIENT shall expressly request to SELLER any special packaging or supplementary protection it deems necessary, and in such event CLIENT will bear all related costs thereof.
- 4.2 Unless otherwise provided for in the Sale Contract, the Products shall be delivered to CLIENT in accordance with the Incoterms® ICC rule, latest version, Ex-Works (EXW) – premises of SELLER indicated in the Sale Contract. CLIENT authorizes SELLER to undersign, in the name and on behalf of CLIENT, any and all transport documents which shall be signed at the time of collection of the Products at the premises of SELLER, such as the CMR. In the event that the ICC Incoterms® rule agreed between the parties provides that CLIENT shall take care of the transportation of the Products outside the territory of Italy:
- a) in case of an Intra-EU supply, within 45 (forty-five) days from the receipt of the Products at its premises, CLIENT shall send SELLER an original or a copy of the international transportation document CMR or of another transportation document, undersigned at destination by CLIENT or, in the absence of the international transportation document CMR, a declaration of receipt of the Products issued on the basis of the form as Annex -1- available for download at www.panariagroup.it;
 - b) in case of an Extra-EU supply, CLIENT shall:
 - i) submit the custom export declaration (SAD-EX + EAD) and execute the validation of the MRN (Movement Reference Number) at the customs of the UE territory of exit of the Products, within 90 (ninety) days from the date of delivery of the same in Italy;
 - ii) send SELLER, within 90 (ninety) days from the date of delivery, documents proving the exportation of the Products (custom export declaration SAD-EX + EAD + certification of exit);
 - iii) notify SELLER, in writing, as soon as such submission is accomplished and provide SELLER with any other document proving the execution of such formalities as well as the exit of the Products from the UE Territory.
- In case CLIENT is in breach of its obligations under this paragraph 4.2, SELLER shall be entitled to immediately charge CLIENT the amount of the Value Added Tax applicable to the supply and connected to the lack of proof of the transportation of the Products in a another Member State of the EU or to the lack of execution of custom clearance formalities. In any case, CLIENT shall indemnify and hold SELLER harmless with reference to any payment due to tax offices for fines, interests or on any other basis, in connection with the supply and with the lack of the proof of the transportation of the Products in a another Member State of the EU or with the lack of execution of custom clearance formalities.
- In this respect, SELLER shall be entitled to: (i) offset any amount due by CLIENT on the basis of this paragraph 4.2 against any amount due, for whatever reason, from SELLER to CLIENT; or (ii) definitively withhold any amount received in regard to Sale Contracts, offsetting the CLIENT's debt under this paragraph 4.2 against any and all sums already paid by CLIENT.
- 4.3 SELLER shall deliver the Products within the delivery date provided for in the Sale Contract, in a single delivery or in partial deliveries. The delivery date shall always be considered neither of the essence nor peremptory. Except in case of wilful wrongdoing or gross negligence, SELLER will not reimburse possible damages, either direct or indirect, suffered by CLIENT as a result of delay in the delivery of the Products.
- In no case of delay in the delivery of the Products shall CLIENT be entitled to terminate the Sale Contract.
- 4.4 Upon receipt of the Products, CLIENT must report possible damages occurred to the packaging and/or shortages or anomalies of the Products occurred during the transport, by notifying details of such events on the transportation document, and must also:
- a) have such notification countersigned by the carrier; and
 - b) immediately inform SELLER thereof, in writing, and send SELLER a copy of the countersigned document by and no later than 8 (eight) day(s) from the date of receipt of the Products.
- Should this not be the case, SELLER shall not be responsible for possible damages losses or theft of the Products occurred during the transport, even if transport risks were, in whole or in part, upon SELLER.

5) Prices – Payment – Late Payment

- 5.1 The Products shall be supplied at the prices agreed between the parties in the Sale Contract or, should no prices be mentioned in the Sale Contract, at the prices resulting from the price list of SELLER in force when the Sale Contract has been executed. Unless otherwise stated in writing, the prices of the Products included in SELLER's price lists, quotations and/or offers are in Euro, net of VAT and for delivery according to the Incoterms® ICC rule, latest version, Ex-Works (EXW) - premises of SELLER indicated in the Sale Contract. Therefore, should a different Incoterms® rule be agreed upon between the parties for the delivery of the Products, the invoiced amount shall be modified accordingly, including in the sale invoice transportation expenses and any other costs connected with the Incoterms® rule agreed between for delivery.
- 5.2 CLIENT shall pay for the Products in accordance with the payments methods and terms provided for in the Sale Contract or otherwise agreed upon in writing between the parties. No payment shall be considered as being made by CLIENT until the relative amount has been credited to the bank account of SELLER. Payment shall be executed by CLIENT in Euro or in the currency of the place where CLIENT has its registered office, at SELLER's discretion, in accordance with the currency indicated by SELLER in the related sale invoice.
- 5.3 If CLIENT is delinquent in its payment obligation, SELLER may:
- a) obtain payment of late payment interest in accordance with the applicable law; and
 - b) withhold ongoing and future deliveries, upon written notice to CLIENT, until all delinquent amounts and late payment interest are fully paid.
- 5.4 If delinquent amounts and late payment interest remain unpaid 30 (thirty) days after the agreed deadline for payment, then SELLER may also, at its option, alternatively or cumulatively, and in addition to any other right or remedy available at law or pursuant to these General Conditions:

- a) request accelerated payment of any and all remaining payments and declare due the total outstanding balance, even if payment by instalment or deferred payment has been agreed upon and/or bills of exchange, promissory notes, cheques or other payment documents have been issued and are falling due;
- b) terminate the Sale Contract in question and definitively withhold any amount received in regard to such Sale Contract or to other Sale Contracts, offsetting the CLIENT's outstanding debt against any and all sums already paid by CLIENT;
- c) carry out future deliveries of Products on a pre-payment basis only, also with reference to supplies still to be executed;
- d) cancel discounts and bonuses that may have been agreed between the parties also with reference to Sale Contracts already regularly executed.

5.5 SELLER shall be entitled to exercise the rights mentioned in paragraphs 5.3 and 5.4 above also in case:

- a) CLIENT is undergoing winding-up, bankruptcy, debt restructuring or enforcement proceedings;
- b) the insurance company of SELLER refuses insurance coverage for SELLER's credits toward CLIENT;
- c) CLIENT is undergoing financial difficulties able to hinder the regular execution of its payment obligations resulting from, by way of example only, missed payment of bills of exchange, promissory notes, cheques or other payment documents, reduction of granted guarantees and/or missed granting of promised guarantees, as well as from any amount resulting unpaid, even though such circumstances have occurred with other suppliers of CLIENT.

5.6 CLIENT cannot claim any breach of contract by SELLER, nor can CLIENT start any lawsuit or action against SELLER, until any amount resulting due to SELLER under paragraphs 5.3 and 5.4 above has been paid in full by CLIENT.

6) Retention of Title

6.1 SELLER will maintain exclusive ownership over the Products sold until their price has been entirely paid by CLIENT.

Without prejudice to the above the risks of loss of the Products shall be regulated by the Incoterms® rule agreed between the parties for the delivery of the Products.

6.2 In case of non-fulfilment or late fulfilment of the obligation to pay the price of the Products, without prejudice to the rights under paragraphs 5.4, 5.5 and 5.6, SELLER shall be entitled to enter the premises where the Products are held, re-possess the Products and withhold, as liquidated damages, any amount already paid by CLIENT with reference to such Products.

7) Warranty

7.1 Without prejudice to the provisions of paragraphs 2.1, 2.2, 2.4 and 3.6 with reference to the modifications to the Products and tolerances, SELLER warrants that the Products will conform to the Sale Contract, to the classification indicated in the technical manuals, catalogues and/or price lists of SELLER and that they will be free from manufacturing defects.

The warranty period is 12 (twelve) months from the date of collection of the Products from the premises of SELLER, regardless of the agreed Incoterms® rule for delivery.

7.2 The following are expressly excluded from warranty:

- a) chromatic alterations and tone differences of the Products;
- b) the Products identified in the Sale Contract as Products of quality lower than first-quality Products or as close-out sale Products or as special batches;
- c) the Products applied and/or set up not in compliance with the industry standards applicable to the same;
- d) the Products used or applied on surfaces and/or in spaces or environments different from those indicated by SELLER;
- e) the Products used not in compliance with the instructions and/or indications provided by SELLER included in the catalogues and price lists of SELLER or in other way communicated to CLIENT by SELLER, included the instructions under paragraph 2.2;
- f) the Products used not in compliance to the standard diligence and/or to the technics required by the nature of the Products;
- g) frost resistance of the Products, unless such characteristic of the Products has been declared by SELLER in the technical manual of the Products;
- h) characteristics of the Products as resulting from the classification of the pottery (i) executed by control and/or certification authorities other than authorities of the European Union Member States, and/or (ii) executed on the basis of criteria other than those used by SELLER.

7.3 Without prejudice to the provisions of paragraph 4.4 above, CLIENT shall inspect the Products as soon as possible and shall notify SELLER in writing of possible non-conformities or defects, by fax or email, within and no later than the following terms; failing to do so will result in the lapse of the warranty and the unenforceability of the warranty rights:

- a) differences in type or quantity with respect to type or quantity agreed as well as other patent non-conformities or defects of the Products: 8 (eight) days from the delivery of the Products at the premises of CLIENT and, in any case, before application of the Products;
- b) hidden non-conformities or defects of the Products: 8 (eight) days from the discovery of the same and, for avoidance of doubt, within the warranty period.

7.4 SELLER will have the right to examine the Products, or samples of the Products, which CLIENT claims to be non-conforming or defective, in order to verify the instructions relating to the set up and/or application of the Products and/or the use of the Products in accordance with the provisions of these General Conditions. In this respect, CLIENT shall be entitled to return to SELLER the Products that CLIENT considers to be non-conforming or defective only upon SELLER's written authorization and only on the condition that CLIENT bears all costs and risks for the shipment of the Products. The authorization to return the Products or samples of the purportedly non-conforming or defective Products shall never be interpreted as an acknowledgment of the claimed non-conformities or defects on the part of SELLER.

7.5 In case the Products are ascertained by SELLER as actually non-conforming or defective, CLIENT will be entitled only to obtain, at the SELLER's option:

- a) replacement of the non-conforming or defective Products; or
- b) partial or full exemption from payment of their price, depending on the seriousness of the non-conformities or of the defects.

7.6 For the purpose of paragraph 7.5 letter (a), the Products to be delivered in replacement of non-conforming or defective Products shall be delivered to CLIENT in accordance with the Incoterms® 2010 ICC rule DDP - premises of CLIENT. The Products that have been replaced shall be, at SELLER's discretion, destroyed or disposed of by CLIENT, at its own costs, or returned to SELLER, at costs of SELLER. In case the Products are to be destroyed or disposed of by CLIENT, CLIENT undertakes to send to SELLER the proof of destruction or of disposal of the Products, along with the documents proving the costs borne by CLIENT for the destruction or the disposal of the same.

7.7 The rights and remedies described in paragraphs 7.5 and 7.6 above are the sole warranty rights and remedies granted to CLIENT. To the maximum extent permitted by the applicable law, any other liability and obligation of SELLER, which may in any way arise from or in relation to the supply of non-conforming or defective Products - including, but not limited to, compensation for direct or indirect or consequential damages, loss of profits, etc. connected to such liability - is expressly excluded.

7.8 The present warranty is in substitution for, and excludes, any other warranty, express or implied, set forth by the law or otherwise.

8) Force Majeure

8.1 SELLER shall not be liable or responsible for failure or delay in performing or fulfilling any obligations undertaken in reference to the supply of Products when such failure or delay is due to the occurrence of an event of force majeure such as wars, fires, earthquakes, floods, tsunamis, strikes, labor or employment difficulties, shortage or procurement difficulties of raw materials, restriction on the use of power, suspension or difficulties in the transports, breakdown of the plants, acts of public authorities or any other event or cause whatsoever, similar or dissimilar, which cannot reasonably be forecast or provided against and which cannot be overcome by SELLER with reasonable diligence.

8.2 In such event, the time for fulfilment of the obligation shall be extended for the period of continuance of such force majeure event.

In the event any of such force majeure event continue for a period longer than 6 (six) months, CLIENT shall have the right to terminate the underlying Sale Contract, by giving written notice to SELLER by registered letter with return receipt or courier, and SELLER shall not incur any responsibility or liability whatsoever.

9) Severability

The invalidity or unenforceability of any provision, or portion thereof, of this General Conditions shall not affect the validity or enforceability of any other provision.

10) Confidentiality

10.1 CLIENT undertakes: (i) to treat with the utmost confidentiality all the information/data/designs/know-how/documentation transmitted by SELLER or that it may come to know in connection with the execution of any Sale Contract, even if they are not marked or identified as secret or confidential ("Confidential Information"); (ii) not to, wholly or partially, disclose to or inform third parties of the Confidential Information, without the SELLER's prior written consent; (iii) to limit the use of the Confidential Information and the access to the same for purposes relating to the execution of the sale Contracts; (iv) to adopt any and all measures required in order for its employees and collaborators do not disclose the Confidential Information to third parties or use it in an inappropriate way.

The Confidential Information shall not be copied or reproduced in any way, unless with the prior written consent of SELLER, and all the copies of the Confidential Information shall be immediately returned to SELLER upon simple written request of the same.

10.2 The provisions above shall not apply to information which (i) are public or publicly available not due to a disclosure of CLIENT or of CLIENT's employees or collaborators; or (ii) were already available to CLIENT before it had received them by SELLER; or (iii) are disclosed from third parties that have no obligation of confidentiality or restrictions of use on the same; (iv) can be disclosed according to a written authorization of SELLER.

11) Applicable Law – Dispute Resolution

11.1 These General Conditions and all the Sale Contracts that will occur on the basis on the same will be governed by the United Nations Convention on Contracts for the International Sale of Goods (Vienna Convention of 1980) and, with respect to matters not covered by such Convention, by Italian laws.

11.2 Any dispute arising out of or in connection with these General Conditions or in connection with a Sale Contract occurred on the basis on the same shall be settled in accordance with the following provisions:

- a) In case CLIENT has its registered office within the European Union, in Switzerland, in Norway or in Iceland, the dispute shall be subjected to the jurisdiction of the Italian courts and shall be exclusively referred for its resolution to the Court of Modena (Italy).
- b) In any other case, the dispute shall be exclusively referred to and finally resolved by arbitration, by a sole arbitrator, in accordance with the Rules of the Milan Chamber of Arbitration (the Rules).

The seat of arbitration shall be, and the award shall be delivered in, Milan (Italy).

The language to be used in the arbitral proceedings shall be English.

11.3 Irrespective of the provisions above, it is hereby granted exclusively to SELLER the right to initiate legal proceedings under the jurisdiction of CLIENT before the competent court.

12) Language of these General Conditions

12.1 The text of these General Conditions is executed in both in Italian and in English language. In case of any discrepancy, the text in Italian shall prevail over the text in English language.

These general terms and conditions of sale are published and downloadable on the website www.panariagroup.it

Le rappresentazioni fotografiche e descrittive dei prodotti di Lea Ceramiche riportate sui depliant, sui cataloghi e sugli altri materiali pubblicitari dell'azienda, sono puramente illustrative dello specifico prodotto rappresentato.

Si precisa infatti che, successivamente alla pubblicazione dei materiali pubblicitari dell'azienda, il prodotto potrebbe subire leggere modifiche nel relativo processo produttivo, al fine di renderlo tecnologicamente migliore. Tali aggiustamenti tecnologici potrebbero determinare lievi differenze, anche estetiche e/o cromatiche, nel prodotto medesimo, con la conseguenza che lo stesso potrebbe risultare diverso da come rappresentato e/o illustrato e/o descritto nel materiale pubblicitario di Lea Ceramiche. Tali differenze non potranno essere in alcun modo considerate dall'acquirente un vizio e/o difetto del materiale ceramico stesso, bensì una caratteristica dello specifico prodotto. Tutti i materiali ceramici che imitano pietre naturali presentano differenze di colore e sfumature che non potranno in nessun modo essere considerate quale difetto del prodotto, ma bensì una qualità caratteristica di tali tipi di produzione.

The photographs and descriptions of Lea Ceramiche products given in the brochures, catalogues and other corporate advertising materials aim merely to represent the specific products.

After the publication of the corporate advertising materials, the products may be slightly modified as a result of technological improvements. Such technological modifications may lead to slight differences in appearance and/or colour of the products, which may therefore differ from the representations, illustrations or descriptions given in the Lea Ceramiche advertising materials. Such differences shall in no way be deemed to be faults and/or defects in the ceramic materials, but rather intrinsic features of the specific products.

All ceramic materials that imitate natural stone differ in color and nuances, and this cannot in any way be considered as a product defect, but rather a characteristic of these types of products.

Les représentations photographiques et descriptives des produits de Lea Ceramiche reportées au sein des dépliant, des catalogues et des autres matériels publicitaires de l'entreprise visent simplement à illustrer le produit spécifique représenté.

En effet, nous précisons que suite à la publication des matériels publicitaires de l'entreprise, le produit pourrait subir de légères modifications lors du processus de production afin de le rendre meilleur du point de vue technologique. Ces ajustements technologiques pourraient engendrer de légères différences, même esthétiques et/ou chromatiques, au niveau du produit même, impliquant que celui-ci pourrait diverger des représentations et/ou des illustrations et/ou des descriptions contenues dans le matériel publicitaire de Lea Ceramiche. Ces différences ne pourront en aucun cas être considérées par l'acquéreur comme une imperfection et/ou un défaut du matériau céramique, mais plutôt comme une caractéristique du produit spécifique.

Tous les matériaux céramiques imitant les pierres naturelles présentent des différences de couleur et des nuances qui ne pourront en aucun cas être considérés comme un défaut du produit, mais, en revanche, comme une caractéristique typique de ces productions.

Die in den Prospekten, Katalogen und sonstigen Werbematerialien der Firma enthaltenen fotografischen Darstellungen und Beschreibungen der Produkte von Lea Ceramiche dienen nur zur Veranschaulichung des jeweils dargestellten Produkts.

Wir weisen darauf hin, dass nach der Veröffentlichung der Werbematerialien der Firma leichte Änderungen bezüglich des Produktionsprozesses am Produkt vorgenommen werden könnten, um es in technologischer Hinsicht zu verbessern. Diese technischen Abänderungen könnten zu leichten z.B. ästhetischen und/oder farblichen Unterschieden am Produkt führen, das folglich von dem im Werbematerial von Lea Ceramiche dargestellten und/oder veranschaulichten und/oder beschriebenen Produkt abweichen könnte. Diese Unterschiede dürfen vom Käufer in keiner Weise als Mangel und/oder Defekt des Keramikmaterials angesehen werden, sondern sind ein Merkmal des spezifischen Produkts. Die keramischen Materialien die Natursteine nachbilden (imitieren), die Farbuunterschieden haben, sind nicht als Fehler des Materials zu bezeichnen, sondern als typische Merkmale.



P R () T E C T

444/
445

L'esclusiva tecnologia Panariagroup per pavimenti e rivestimenti antibatterici ad altissime performance.
Per un abitare sano, sicuro e protetto.

The exclusive Panariagroup technology for floor and wall coverings with the highest performance.
To live healthy, safe and secure.

La technologie exclusive de Panariagroup pour les revêtements de sols et de murs antibactériens
à hautes performances. Pour un habitat sain, sûr et protégé.

Die exklusive Technologie Panariagroup für antibakterielle und hochleistungsfähige Fußböden
und Verkleidungen. Für ein gesundes, sicheres und geschütztes Wohnen.



AZIONE POTENTE

elimina i batteri e ne impedisce
la proliferazione

POWERFUL ACTION

eliminates microbes and prevents
their reproduction

ACTION PUISSANTE

élimine les bactéries et empêche
leur prolifération

LEISTUNGSSTARKE WIRKUNG

eliminiert Bakterien
und verhindert die
Vermehrung



PROTEZIONE CONTINUA

sempre attivo, 24 ore su 24,
con e senza luce solare

PROTECTION CONTINUE

always active, 24 hours a day,
with and without sunlight

PROTECTION CONTINUE

toujours actif, 24 heures sur 24,
avec et sans lumière du soleil

DAUERSCHUTZ

rund um die Uhr aktiv,
mit oder ohne
Sonnenlicht



EFFICACIA ETERNA

grazie alla tecnologia integrata
in modo permanente nel prodotto

ETERNAL EFFECTIVENNES

thanks to the technology permanently
integrated into the product

EFFICACITÉ ÉTERNELLE

grâce à la technologie intégrée de façon
permanente dans le produit

DAUERHAFTHE WIRKSAMKEIT

dank der permanent
im Produkt integrierten
Technologie



QUALITÀ GARANTITA

dalla partnership con **MICROBAN**[®]

GUARANTEED QUALITY

by the partnership with **MICROBAN**[®]

QUALITÉ GARANTIE

du partenariat avec **MICROBAN**[®]

GARANTIERTE QUALITÄT

dank der Partnership mit
MICROBAN[®]

LEA

CERAMICHE

PANARIAgroup
INDUSTRIE CERAMICHE S.P.A.

AN INTERNATIONAL GROUP WITH STRONG VALUES

LEADERSHIP TECNOLOGICA

Investiamo costantemente in ricerca, tecnologie e stabilimenti all'avanguardia per rispondere ad ogni esigenza dell'architettura e dell'interior design con soluzioni innovative, capaci di diventare punto di riferimento del settore.

QUALITÀ ED ECCELLENZA ESTETICA

Ricerchiamo con tenacia l'eccellenza industriale, dalla qualità delle materie prime all'efficienza del processo, per ottenere prodotti in grado di coniugare assoluto valore estetico a elevatissime prestazioni tecniche.

RESPONSABILITÀ

Mettiamo sempre la persona e la qualità della vita al centro delle nostre attenzioni, con prodotti sicuri, sostenibili per l'ambiente, operando nel massimo rispetto di chi lavora con noi.

AFFIDABILITÀ

La garanzia di un Gruppo che, dalle radici familiari nel distretto ceramico di Sassuolo alla quotazione alla Borsa di Milano, è cresciuto fino a diventare una solida realtà internazionale, che opera ovunque nel mondo mantenendo un cuore italiano.

TECHNOLOGICAL LEADERSHIP

We continuously invest in research, technology, and cutting-edge facilities to respond to every need of architecture and interior design with innovative solutions that become a point of reference in the industry.

QUALITY AND AESTHETIC EXCELLENCE

We tenaciously seek industrial excellence, from the quality of raw materials to process efficiency, achieving products that combine the utmost aesthetic value with the highest technical performance.

RESPONSIBILITY

We always place people and quality of life at the center of our focus, with products that are safe and environmentally sustainable, operating with maximum respect for those who work with us.

RELIABILITY

The reliability of a Group that, from its family roots within the ceramic district of Sassuolo to its listing in Milan Stock Exchange, has grown to become an international company, operating worldwide with an Italian heart.



LEADERSHIP TECHNOLOGIQUE

Pour répondre efficacement aux exigences de l'architecture et de la décoration d'intérieur, nous investissons en permanence dans la recherche, la technologie et les productions à l'avant-garde, pour fournir des solutions innovantes qui, par la suite, deviennent de véritables références dans ce secteur.

QUALITÉ ET EXCELLENCE ESTHÉTIQUE

Notre recherche obstinée de l'excellence industrielle nous influence dans le choix de nos matières premières jusqu'à l'étape finale de réalisation, pour vous livrer des produits d'une valeur esthétique absolue, dotés de performances techniques supérieures.

RESPONSABILITÉ

Nous plaçons toujours au centre de nos attentions la personne et la qualité de vie, en vous proposant des produits sûrs et durables, tout en travaillant dans le respect de nos employés et collaborateurs.

CONFIANCE

Née au cœur du quartier céramiste de Sassuolo et aujourd'hui coté en bourse à Milan, notre entreprise se base sur les valeurs sûres de la famille. Reconnue au niveau international, nous opérons dans le monde entier, tout en vous garantissant l'excellence du Made in Italy.

TECHNOLOGISCHES LEADERSHIP

Wir investieren konstant in die Forschung, in Technologien und in fortschrittliche Produktionswerke, um jedem Bedürfnis der Architektur und des Innendesigns mit innovativen Lösungen gerecht zu werden und in der Lage zu sein zu einem Bezugspunkt für die Branche zu werden.

QUALITÄT UND ÄSTHETISCHE EXZELLENZ

Wir verfolgen hartnäckig die industrielle Exzellenz, von der Qualität der Rohstoffe bis zur Effizienz des Prozesses, um Produkte zu erhalten, die in der Lage sind, den absoluten ästhetischen Wert mit höchsten technologischen Leistungen zu verbinden.

VERANTWORTUNG

Für uns steht der Mensch und die Lebensqualität immer an erster Stelle. Unsere Produkte sind sicher und umweltfreundlich und werden mit höchstem Respekt für die Personen hergestellt, die mit uns zusammen arbeiten.

ZUVERLÄSSIGKEIT

Die Garantie einer Gruppe, die aus den familiären Wurzeln der Keramik in Sassuolo bis zur Notierung an der Mailänder Börse bis hin zu einer soliden internationalen Realität gewachsen und heute weltweit unter Beibehaltung des italienischen Herzens tätig ist.

LEA

CERAMICHE

LEA CERAMICHE

Via Cameazzo, 21
41042 Fiorano Modenese
Modena Italy

Tel +39 0536 837811
Fax +39 0536 830326
info@ceramichelea.it
www.ceramichelea.com

**Panariagroup Industrie Ceramiche
S.p.A.**

SHOWROOM LEA CERAMICHE

Via Durini, 3
20122 Milano

Tel +39 02 76011406
showroom_milano@ceramichelea.it

LEA NORTH AMERICA, LLC

800 Clanton Road, Suite N
Charlotte, NC 28217

Tel +1 704 522 6300
Fax +1 704 522 6080
info@leausa.us
www.leausa.us